

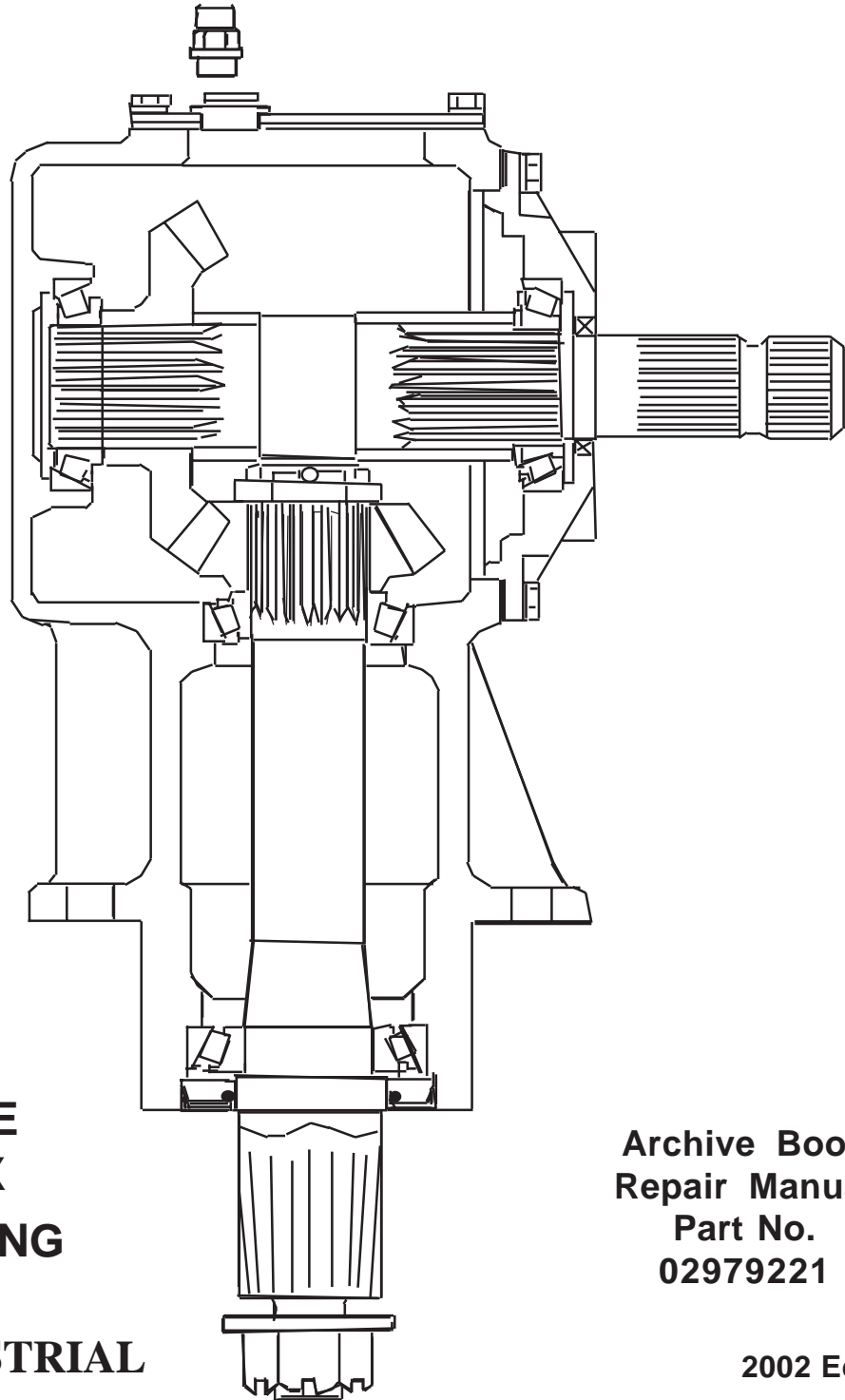

Mechanical Gearbox Archive-Repair Manual

By Gearbox P/N & Mower Model



**COMPLETE
GEARBOX
PARTS LISTING**

**Archive Book
Repair Manual
Part No.
02979221**

ALAMO INDUSTRIAL

1502 E. Walnut
Seguin, Texas 78155
830-372-3551

2002 Edition

© 2002 Alamo Group Inc.

An Alamo Group Company

NOTES

Index By Model

MODEL	RPM	Part No	Date Used	Page No.
AC48 - AC60				
	540.....	001544.....	Aug. 1991 to Current.....	6 - 7
AF60 - AF72				
	540.....	4800.....	Nov. 1990 to Mar. 1995.....	194 - 195
		00763623.....	Apr. 1995 to Current.....	112 - 113
AG120				
Divider G/B Centered Model				
	540.....	00760880.....	Feb. 1996 to Current.....	108 - 111
	1000.....	00758996.....	Feb. 1996 to Current.....	92 - 95
Outboard G/B Centered Model (LH or RH Blade Box)				
	540 / 1000.....	00756739....	Feb. 1996 to Mar. 1996.....	52 - 55
		00769918.....	Apr 1996 to Current.....	140 - 143
Divider G/B Offset Model (LH Blade Box)				
	540.....	00757918.....	Feb. 1996 to Current.....	80 - 83
Outboard G/B Offset Model (RH Blade Box)				
	540.....	00764053.....	Feb. 1996 to Mar. 1996.....	120 - 123
		00771225.....	Apr. 1996 to Current.....	162 - 165
AG15-IV				
Divider G/B				
	540.....	00753190.....	Mar. 1985 to Apr. 1986.....	16 - 17
		00754005.....	May 1986 to Jan 1988.....	18 - 19
		00756604.....	Feb. 1988 to Mar. 1990.....	40 - 43
		00757825.....	Apr. 1990 to Mar. 1991.....	64 - 67
		00756604.....	Apr, 1991 to Dec. 1994.....	40 - 43
		00769115.....	Jan. 1995 to Current.....	124 - 127
	1000.....	00755698.....	Feb. 1988 to Mar. 1990.....	32 - 35
		00757826.....	Apr. 1990 to Mar. 1991.....	68 - 71
		00755698.....	Apr. 1991 to Dec. 1994.....	32 - 71
		00769116.....	Jan. 1995 to Current.....	128 - 131
Center G/B				
	540.....	00752140(A)..	Mar. 1985 to Apr. 1986.....	12 - 15
		00755598.....	May 1986 to May 1996.....	24 - 27
		00769912.....	Jun 1996 to Current.....	132 - 135
	1000.....	00756622.....	May 1986 to May 1996.....	44 - 47
		00769924.....	Jun. 1996 to Current.....	148 - 151
RH Wing				
	540.....	00752140(A)..	Mar. 1985 to Apr. 1986.....	12 - 15
		00755566.....	May 1986 to May 1996.....	20 - 23
		00769915.....	Jun. 1996 to Current.....	136 - 139
	1000.....	00756741.....	May 1986 to May 1996.....	56 - 59
		00769921.....	Jun 1996 to Current.....	144 - 147
LH Wing				
	540.....	00752141(A)..	Mar. 1985 to Apr. 1986.....	12-15
		00755598.....	May 1986 to May 1996.....	24 - 27
		00769912.....	Jun. 1996 to Current.....	132 - 135
	1000.....	00756739.....	May 1986 to May 1996.....	52 - 55
		00769918.....	Jun. 1996 to Current.....	140 - 143

Index By Model

MODEL	RPM	Part No	Date Used	Page No.
AG20 / AG14				
Divider G/B	540.....	00756604.....	Sep. 1989 to Jul. 1994.....	40 - 43
		00769115.....	Aug. 1994 to Current	124 - 127
	1000.....	00755698.....	Sep. 1989 to Jul. 1994.....	32 - 35
		00769116.....	Aug. 1994 to Current.....	128 - 131
Center G/B	540.....	00755598.....	Sep. 1989 to Nov. 1996.....	24 - 27
		00769912.....	Dec. 1996 to Current.....	132 - 135
	1000.....	00756744.....	Sep. 1989 to Nov. 1996.....	60 - 63
		00769930.....	Dec. 1996 to Current.....	156 - 159
RH Wing	540.....	00756739.....	Sep. 1989 to Nov. 1996.....	52 - 55
		00769918.....	Dec. 1996 to Current.....	140 - 143
	1000.....	00756622.....	Sep. 1989 to Nov. 1996.....	44 - 47
		00769924.....	Dec. 1996 to Current.....	148 - 151
LH Wing	540.....	00756741.....	Sep. 1989 to Nov. 1996.....	56 - 59
		00769921.....	Dec. 1996 to Current.....	144 - 147
	1000.....	00756624.....	Sep. 1989 to Nov. 1996.....	48 - 51
		00769927.....	Dec. 1996 to Current.....	152 - 155
AG415				
Divider G/B	540.....	00757825.....	Mar. 1991 to Nov. 1994.....	64 - 67
		00769115.....	Dec. 1994 to May 1998.....	124 - 127
		00756603A....	Jun. 1998 to Current.....	36 - 39
	1000.....	00757826.....	Mar. 1991 to Nov. 1994.....	68 - 71
		00769116.....	Dec. 1994 to May 1998.....	128 - 131
		00755697A....	Jun. 1998 to Current.....	28 - 31
Center G/B	540.....	00759205B....	Mar. 1991 to Current.....	96 - 101
	1000.....	00760506B....	Mar. 1991 to Current.....	102 - 107
RH Wing	540.....	00759206B....	Mar. 1991 to Current.....	96 - 101
	1000.....	00760507B....	Mar. 1991 to Current.....	102 - 107
LH Wing	540.....	00759205B....	Mar. 1991 to Current.....	96 - 101
	1000.....	00760403B....	Mar. 1991 to Current.....	102 - 107
AG60				
	540.....	00752140A....	Jul. 1988 to Jan. 1990.....	12 - 15
		00757828.....	Feb.1990 to Dec. 1991.....	72 - 75
		00757828B....	Jan. 1992 to Nov. 1998.....	76 - 79
		00769912.....	Dec. 1998 to Current.....	132 - 135
AG60-B				
	540.....	00757828.....	Feb.1990 to Dec. 1991.....	72 - 75
		00757828B....	Jan. 1992 to Feb. 2001.....	76 - 79
		00775919.....	Mar. 2001 to Current.....	166 - 169

Index By Model

MODEL	RPM	Part No	Date Used	Page No.
AG72				
	540.....	00752140A....	Jul. 1988 to Jan. 1990.....	12 - 15
		00757828.....	Feb.1990 to Dec. 1991.....	72 - 75
		00757828B....	Jan. 1992 to Nov. 1998.....	76 - 79
		00769912.....	Dec. 1998 to Current.....	132 - 135
AG72-B				
	540.....	00757828.....	Feb.1990 to Dec. 1991.....	72 - 75
		00757828B....	Jan. 1992 to Feb. 2001.....	76 - 79
		00775919.....	Mar. 2001 to Current.....	166 - 169
AG72-SD				
	540.....	00769912.....	Jun. 1998 to Current.....	132 - 135
AG84-B				
	540.....	00760403B....	Apr. 1991 to Apr. 1996.....	102 - 107
		00760403B....	May 1996 to Current.....	102 - 107
	1000.....	00758217B....	Apr. 1991 to Apr. 1996.....	84 - 89
		00758217B....	May 1996 to Current.....	84 - 89
AG96				
Divider G/B Centered Model				
	540.....	00760880.....	Jun. 1992 to Current.....	108 - 111
	1000.....	00758996.....	Jun. 1992 to Current.....	92 - 95
Outboard G/B Centered Model (LH or RH Blade Box)				
	540 / 1000.....	00759205B....	Jun. 1992 to Apr. 1996.....	96 - 101
		00759205B....	May 1996 to Current.....	96 - 101
Divider G/B Offset Model (LH Blade Box)				
	540.....	00757918.....	Jun. 1992 to Current.....	80 - 83
Outboard G/B Offset Model (RH Blade Box)				
	540.....	00764053.....	Jun. 1992 to Jun. 1997.....	120 - 123
		00771225P.....	Jul. 1997 to Current.....	162 - 165
AT60 - AT74				
	540.....	702673.....	May 1991 to Current.....	198 - 199
BD80				
	540.....	00758959.....	May 1990 to Apr. 1995.....	90 - 91
		00770367.....	May 1995 to Current.....	160 - 161
Grass Flex, 11.5', 13.5', 14.5', 15.5' & 16.5'				
Divider G/B	540.....	00763666.....	Jan. 1993 to Current.....	116 - 119
Rear Deck	540.....	00763623B....	Jan. 1993 to Current.....	114 - 115
Wing Deck	540.....	00752623B....	Jan. 1990 to Current.....	114 - 115

Index By Model

MODEL	RPM	Part No	Date Used	Page No.
Grass Gater 74				
	540.....	702673.....	Jun. 1996 to Current.....	198 - 199
SHD - 50" - 60" - 74" - 88" - 96"				
	540.....	700493.....	Mar. 1972 to Aug. 1990.....	196 - 197
		702673.....	Sep. 1990 to Current.....	198 - 199
Stingray 10 & 15				
Divider G/B	540.....	02978514.....	Mar. 2002 to Current.....	174 - 177
	1000.....	02978968.....	Mar. 2002 to Current.....	186 - 189
Center G/B	540.....	02978513.....	Mar. 2002 to Current.....	170 - 173
	1000.....	02978971.....	Mar. 2002 to Current.....	190 - 193
RH Wing	540 / 1000.....	02978523.....	Mar. 2002 to Current.....	178 - 181
LH Wing	540 / 1000....	02978533.....	Mar. 2002 to Current.....	182 - 185

Index By Gearbox No.

Gearbox No.	Page	Gearbox No.	Page
001544.....	6-7	00757825.....	64-67
00749003.....	8-11	00757826.....	68-71
00752140.....	12 - 15	00757828.....	72-75
00752140A.....	12-15	00757828B.....	76-79
00753190.....	16-17	00757918.....	80-83
00754005.....	18-19	00758217B.....	84-89
00755566.....	20-23	00758959.....	90-91
00755598.....	24-27	00758996.....	92-95
00755697A.....	28-31	00759205B.....	96-101
00755698.....	32-35	00759206B.....	96-101
00756603A.....	36-39	00760403B.....	102-107
00756604.....	40-43	00760506B.....	102-107
00756622.....	44-47	00760507B.....	102-107
00756624.....	48-51	00760880.....	108-111
00756739.....	52-55	00763623.....	112-113
00756741.....	56-59	00763623B.....	114-115
00752141A.....	56-59	00763666.....	116-119
00756744.....	60-63	00764053.....	120-123

Index By Gearbox No.

Gearbox No.	Page	Gearbox No.	Page
00769115.....	124-127	00775919.....	166-169
00769116.....	128-131	02978513.....	170-173
00769912.....	132-135	02978514.....	174-177
00769915.....	136-139	02978523.....	178-181
00769918.....	140-143	02978533.....	182-185
00769921.....	144-147	02978968.....	186-189
00769924.....	148-151	02978971.....	190-193
00769927.....	152-155	4800.....	194-195
00769930.....	156-159	700493.....	196-197
00770367.....	160-161	702673.....	198-199
00771225.....	162-165		

INTRODUCTION GEARBOX REPAIR MANUAL

To Use this Book

- A.** Find Model Type in Index or Find Gearbox Assembly Number in list. Use Parts Breakdown for Gearbox as reference to part assembly order.
- B.** This Book is intended to be a Quick reference Information, See Operator Manual for Model if more information is needed.
- C.** Gearboxes Listed in this Manual show the steps to assemble the Gearbox as well as the Parts Break Down. The Procedure to Dis-Assemble Gearbox is in most cases the reverse of the Assembly procedure.
- D.** The Index is Listed By Model Name and Date gearbox Used. It is also Listed By Gearbox Assembly Number.
- E.** More than one Gearbox Assembly may be referred to on same Page, so read all Part Numbers & Parts Descriptions. The Drawing May Not be exact to Scale for Size, Some drawing may be for different Gearboxes, This refers to Gear Sizes and in some case's Gear Location, Read all directions before assembly.
- F.** Some Gearboxes look very similar, it does not mean parts will interchange, Check all Part Numbers if changing Parts.

GEARBOX P/N 001544

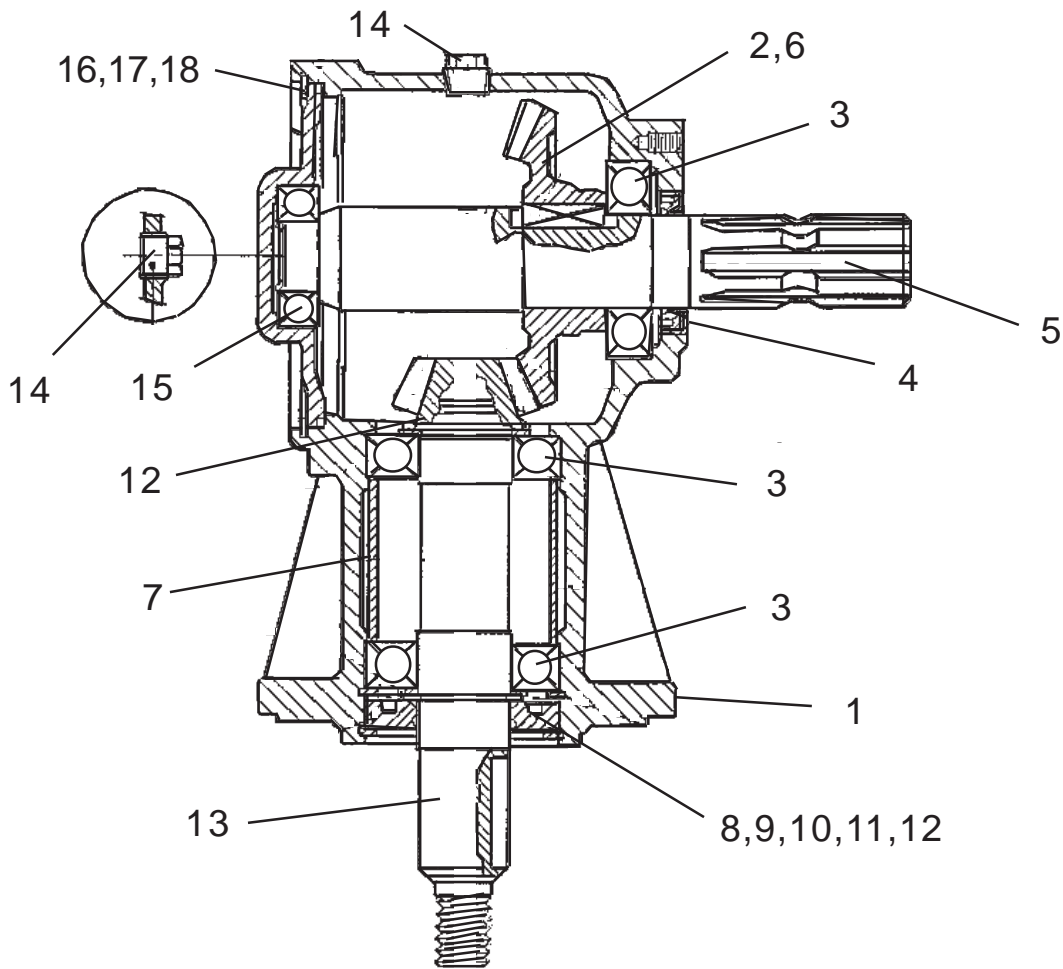

Item	Part No.	Qty	Description
	001544	--	Gearbox Asy, (540 RPM)
1	4829	1	Casing
2	4832	1	Key
3	001726	3	Bearing
4	4834	1	Oil Seal
5	4835	1	Input Shaft
6	4836	1	Crown Gear (30 teeth)
7	4837	1	Spacer
8	001721	1	Internal Clip
9	4839	1	External Clip
10	4847	1	Shoulder Ring
11	4848	1	Seal, Dust Shield
12	001715	2	Shim
13	4850	1	Output Shaft (12 teeth)
14	001713	2	Plug
15	4852	1	Bearing
16	4853	1	Cover
17	4855	1	Shoulder Ring
18	4857	1	O-Ring

GEARBOX

P/N 001544

Assembly Instructions

- 1. Installing Input Shaft and Gear,** Install Front Bearing (item 3) into Main Housing (item 1) Bearing will install from back side of Housing.
- Install Key (item 2) into Input Shaft, Slide input Gear (item 6) on to Shaft from front Side.
- Install Input Seal into Main Housing from the Out Side or Seal can be installed later if wanted, If Seal is installed coat ID of Seal with light coat of Grease and also coat area on Shaft where Seal contacts Shaft.
- Drop Input Shaft with Gear on it through Seal and Main Housing from the Back of Main Housing. Use caution not to damage Input Seal if it has been installed
- Insert Rear Cover O-Ring (item 18) into Housing and coat it with a light coat of grease. Push Rear Cover (item 16) into Housing, Cover is held in place by Shoulder Ring (item 17) which is installed now.
- 6. Installing Output Shaft** (item 13) , with Bearings and componts as shown in Drawing into Main Housing (Item 1), install Input shaft before installing Output Shaft
- Install components onto Output Shaft (item 13), First slide the Shims (item 12) at top of Output Shaft under Gear on use the same quantity as was removed, Install Top Bearing (item 3) on till it seats against Shims.
- Slide Lower Bearing Spacer (item 7) on Output Shaft, This Spacer has the OD same as the Bearings so it will be loose on Shaft. Put Lower Bearing (item 3) on Shaft til it seats against Bearing Spacer.
- Install more Shims (item 12) on output shaft, Use same Quantity as was taken off. Install the External Snap ring (item 9) onto Output Shaft.
- The Out out Shaft, Bearings, Shims, Bearing Spacer and Snap Ring should be all one assembly now. Slide this assembly up into Main Housing from the Bottom, It may be required to move Bearing spacer side to side to keep it lined up. Slide assembly in till upper Bearing bottoms out in Housing.
- Install Lower Internal Snap Ring (item 8) into lower end of Main Housing, This retains Output Shaft and components. DO NOT install lower Seal at this Time.
- Check Shaft for end Play and Gear Back-Lash, there should be no end play, If there is install more Shims (item 12) on Shaft, If Shaft is to tight use less Shims. Gear Back-Lash should be .016" to .019" if it is not then move Shims (item 12) from Top to Bottom or Bottom to Top, Where ever they are moved from they will have to go to the other end to keep End Play correct.
- Install Lower Seal (Item 11 Dust Shield), Coat Seal ID with light coat of grease, Install Shoulder Ring (item 10)
- Fill Gearbox with oil. DO NOT Fill with Oil above Oil Level Plug. Wait a while let Gearbox sit and have time for Oil to run down into lower Bearings and recheck Oil Level. ALWAYS recheck Oil Level after running Mower 1/2 to 1 hour. Inspect Seals for leaking after filling with Oil and after running 1/2 to 1 hour.

Gearbox

P/N 00749003

Top View

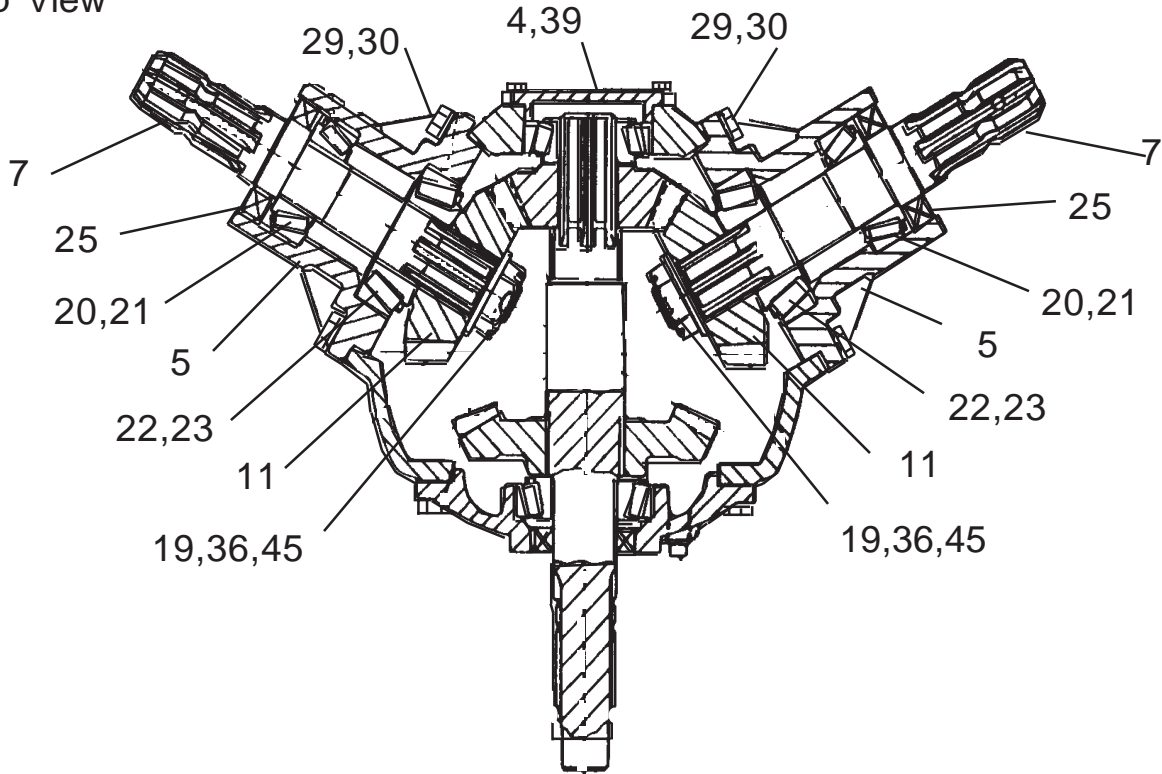

Right Side View

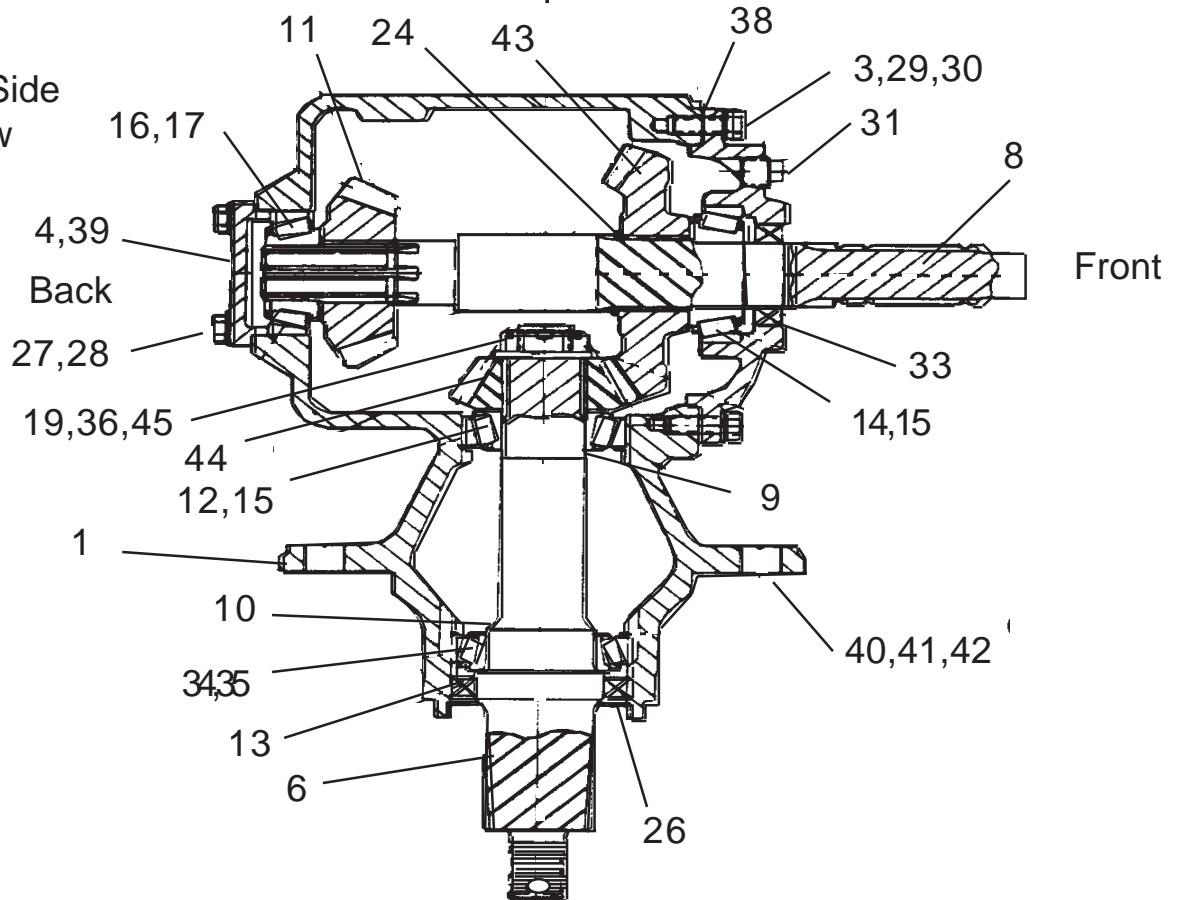

Gearbox

P/N 00749003

Item	Part No.	Qty.	Description	Item	Part No.	Qty.	Description
	00749003	--	Gearbox Asy (540 RPM)	32	00749508	1	Plug
				33	00749509	1	Seal
1	00749477	1	Main Housing	34	00749510	1	Bearing Cup
2	00749478	1	Cover	35	00749511	1	Bearing Cone
3	00749479	-	Locking Compound	36	00749512	3	Nut, Slotted
4	00749480	1	Cap	37	00749513	3	Shim, Fiber .005"
5	00749481	2	Housing Divider		00749514	3	Shim, Alum .007"
6	00749482	1	Shaft, Blade		00749515	1	Shim, Alum .020"
7	00749483	2	Shaft, Side Output	38	00749516	1	Shim, Alum .005"
8	00749484	1	Shaft, Input		00749517	2	Shim, Alum .007"
9	00749485	1	Retaining Ring		00749518	1	Shim, Alum .020"
10	00749486	1	Retaining Ring	39	00749519	2	Shim, .005"
11	00749487	3	Gear, 17 Tooth		00749520	2	Shim, .007"
12	00749488	1	Bearing Cup	40	00748539	4	Nut
13	00749489	1	Seal	41	00748538	4	Bolt
14	00757533	1	Bearing Cup	42	00003901	4	Lockwasher
15	00749491	1	Bearing Cone	43	00749524	1	Gear, 25 Tooth
16	00749492	1	Bearing Cup	44	00749525	1	Gear, 17 Tooth
17	00749493	1	Bearing Cone	45	00749526	3	Washer
18	00749494	1	Bearing Cone				
19	00749495	3	Cotter Pin				
20	00749496	2	Bearing Cup				
21	00749497	2	Bearing Cone				
22	00749498	2	Bearing Cup				
23	00749499	2	Bearing Cone				
24	00749500	1	Retaining Ring				
25	00749501	2	Seal				
26	00749502	1	Plug				
27	00749503	4	Bolt, Hex Head				
28	00749504	4	Lockwasher				
29	00749505	14	Bolt, Hex Head				
30	00022200	14	Lockwasher				
31	00749507	1	Plug, Vent				

Gearbox

P/N 00749003

Assembly Instructions

Installation Part Numbers are for Gearbox #00749003 (540 RPM)

- 1. Install Output Shaft (Blade Shaft) First**, Install Bearings, Gears, Shafts and Components in Main Housing (item 1)
- Inspect Main Housing (item 1), Front Bearing Cap (item 2), Rear Bearing Cap (item 4) and the two Side Drive Housings (item 5) for condition, this will include checking where Retaining Ring (item 9 & 10) are inserted in lower end (output Shaft area), All seal areas for Burrs or scratches that will cause Seals to Leak., Inspect all Bolt Holes and threads, Inspect all areas where Bearing Cups must seat.
- Install Internal Snap Ring (item 10) into bottom and Internal Snap Ring (item 9) into Main Housing (item 1) lower opening for Output Shaft. Make sure they are seated in grooves completely.
- Slide Lower Bearing Cup (item 34) thick end first into housing from the bottom, Cup should go in till it is seated against lower Retaining Ring (item 10). Slide Upper Bearing Cup (item 12) thick end first into opening from the top, it will slide it till it seats against upper Retaining Ring (item 9).
- Slide Bearing Cone (item 35) down onto Output Blade Shaft (item 6) from the top (gear end) till it is seated against Shoulder at Bottom. Slide Blade Shaft (item 6) up into Main Housing from the bottom till lower Bearing Cone is seated into lower Bearing Cup. Slide the upper bearing Cone onto Blade Shaft from the top till it is seated into upper Bearing Cup. Slide the Blade Output Gear (item 44) down over Shaft from Top. Install washer (item 45) on shaft on top of Gear, Screw Slotted Nut (item 36) onto top of Blade Output Shaft
- Adjust Bearing Preload in Blade Output Shaft by tightening the Slotted Nut (item 36). Set Pre-Load at 14" to 16" lbs of rolling torque, After Set use a coated Hammer or a Brass Drift Pin to tap Shaft to be sure Bearing Cones are seated in Bearing Cups and straight on Shaft, then recheck Bearing Pre-Load.
- Coat Lower Seal (item 13) ID with a light coat of grease and install it into lower end of Main Housing. Drive Seal Protector (item 26) into lower end of Main Housing over Output Shaft.
- 8. Install Input Shaft (PTO) Second**, Bearings, 2 Gears and Bearing Caps into Main Housing (item 1)
- Install External Retaining Ring (item 24) onto Input Shaft (item 8), Install Output Gear (item 11) onto back side of Input Shaft till it seats against shoulder on shaft. Slide Inner Input Bearing Cone (item 17) onto back Side of input shaft till it seats against gear.
- 10.** Bolt Rear Bearing Cap (item 4) with Shims (item 39 a/r) using Bolts (item 27) into back of Main Housing. Snug Bolts for now do not Torque them. from the Inside slide Inner Bearing Cup (item 16) into Housing till it seats against rear bearing cap. With Main Housing laying on its back, Stick one hand in through Side Shaft Housing opening so as you drop the Input shaft with rear gear & Bearing installed you can them on shaft while you slide it into housing. Slide Shaft in till Bearing Cone is seated in cup and shaft is in Bearing Cone as far as it will go.

Gearbox

P/N 00749003

Assembly Instructions

11. Slide Input Gear (item 43) down over Input Shaft till it is bottomed out against External Retaining Ring (24) that was installed on shaft earlier. If Gear will not seat against Snap Ring check Number of Shims (item 39) used at rear Bearing Cap. Drop Outer Input Bearing Cone (item 15) down over input Shaft till it seats against Gear (item 43).
12. Install Outer Bearing Cup (item 14) into Front Bearing cap (item 2) using Shims (item 38 a/r) slide front bearing cap down over Input Shaft, Bolt (item 29) Bearing cap to front of Main Housing snug but do not torque go to step 13.
13. There are two adjustments that must be performed now, First is Bearing Pre-Load on Input shaft. Pre-Load should be 14" to 16" lbs of rolling Torque, this is done by adding or removing shims to front and/ or rear cover. DO NOT try to set Gear Back lash at this time leave it wide enough that the Bearing Pre-Load is not affected. When Bearing Pre-Load is correct it is time to set Gear Back-Lash, It will be set at .016" to .019", this is done by moving Shims, Example if more Back-Lash is needed remove a .007" Shim from rear Bearing cap and add a .007" Shim to front Bearing cap or Vice versa, if less Back-Lash is needed, But always add a shim to the opposite end when one is remove or added this will keep Bearing Pre-Load from changing. Tighten Retaining Bolts (item 24) on front Bearing cap & (Item 27) on rear bearing Cap and recheck settings.
14. Install Input Shaft front Seal (item 33) now, Coat the ID of Seal with Light coat of grease before installing into Bearing cap (item 2).
15. **Install Side Output Shaft (Side Drive) Third & Fourth**, Bearings, Gear into Side Drive Housings (item 5) and install Side Drive Housing Assembly into Main Housing (item 1), Left & Right Side Drive Housing Assemblys will Assemble the Same.
16. Install Inner Bearing Cup (item 22) and Outer Bearing Cup (item 20) into Side Drive Housing (item 5), Install bearing Cups till they are seated into Housing. Install Outer Bearing Cone (item 21) onto Side Drive Shaft (item 7) from gear end till it is seated against shoulder on shaft. Drop Shaft into Housing from gear Side. Slide inner Bearing Cone (item 23) onto Shaft from Gear end. Slide Gear (item 11) down on Shaft till seated against Bearing Cone. Install Washer (item 45) on shaft and Screw Slotted Nut (item 36) onto Shaft.
17. Tighten Nut till slack is removed from Shaft & Bearings, Using a coated Hammer and/or Brass Drift Pin and tap Shaft to make sure Bearings are seated. Tight Nut till you have a Bearing Pre-Load of 14" to 16" lbs of Rolling Torque, install Cotter Pin (item 19) into end of Shaft to retain Slotted Nut. Coat Side Drive Seal (item 25) ID with a light coat of grease and install it into Housing. Repeat this process for the other Side Drive Assembly.
18. When Installing the Side Drive Housing Assembly into the Main Housing Assembly use the Side Drive Housing Shims (item 37 a/r) to adjust Gear Back-Lash, More Shims will increase Back-Lash and Less Shims will decrease it. Set Gears (item 11) Back-Lash at .016" to .019" clearance
19. Fill Gearbox with Oil, Before deciding Gearbox is full wait long enough for Oil to run down between Output Shaft Bearing and Side Drive Bearings, Then recheck and refill with Oil, DO NOT fill above Oil Level Plug, install Oil Plugs and check for leaks, After running Mower 1/2 to 1 hour check Oil Level and recheck for leaks.

GEARBOX P/N

00752140 & 00752140A

00752141 & 00752141A

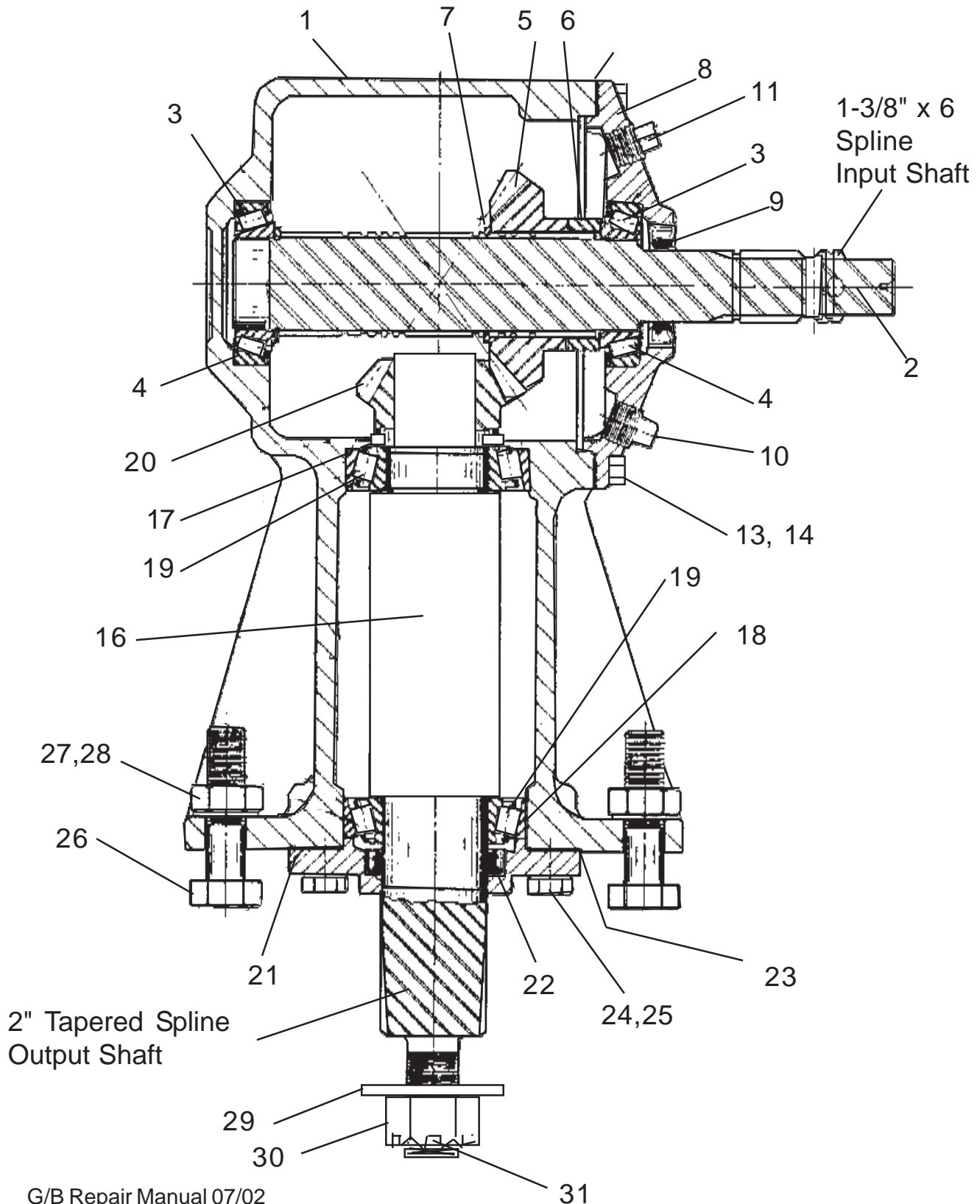

GEARBOX P/N

00752140 & 00752140A

00752141 & 00752141A

Item	Part No.	Qty	Description
	00752140A	--	Gearbox Asy (540 RPM) Input Gear in Front (Shown)
	00752141A	--	Gearbox Asy (540 RPM) Input Gear in Back
1	00752362	1	Main Housing
2	00752363	1	Input Shaft
3	00748525	2	Bearing Cup
4	00748527	2	Bearing Cone
5	00755505	1	Gear, Input 19 Tooth (540 RPM)
6	00748533	1	Spacer
7	00748526		Snap Ring
8	00752365	1	Side Housing
9	00748536	1	Seal
10	00564900	1	Plug
11	00752307	1	Plug
12	00752407	1	Plug (Not Shown)
13	00012101	8	Lockwasher (Not Shown)
14	00563300	8	Bolt (Not Shown)
15	00748531	a/r	Shim
16	00755507	1	Output Shaft
17	00748537	1	Bearing Cup
18	00020600	1	Bearing Cup
19	00748522	2	Bearing Cone
20	00755506	1	Gear, Output 13 Tooth (540 RPM)
21	00752155	1	Bearing Retainer Cap
22	00748519	1	Seal
23	00748520	a/r	Shim
24	00001300	4	Lockwasher
25	02044000	4	Bolt
26	02880900	4	Bolt
27	00037200	4	Nut
28	00003901	4	Lockwasher
29	00748547	1	Flat Washer (Blade Hub Retaining)
30	00606100	1	Nut (Blade Hub Retaining)
31	00606000	1	Cotter Pin (Blade Hub Retaining)

Note: a/r = Use Qty. As Required

This Gearbox Has a 1-3/8" X 6 Spline Input Shaft & 2" Tapered Spline Output Shaft with No Lower Bearing Spacer, Also the input shaft where clutch slides on has snap ring grooves in it with machined pilot surface on the very end that is about 3/4" long., The Front Bearing Cover has 3 pipe plugs (2 large & 1 small) that screw into it, the later gearboxes the plugs screw into the Main Housing or Top Cover.

GEARBOX P/N

00752140 & 00752140A

00752141 & 00752141A

Assembly Instructions

Gearbox # 00752140A Input Gear in Front (as shown in drawing) & # 00752141A Input gear in Back (not shown) (540 RPM)

1. **Install Output Shaft** (Blade Shaft), Bearings, Gear in Main Housing (#00752362)
2. Install Output shafts Upper Bearing Cup (#00748537) into upper portion of Main Housing, Also install inner Bearing Cup (#00748525) for Input Shaft into Back side of Main Housing now. Install Upper Bearing Cone (00748522) onto top of Output Shaft, from the bottom of Main Housing Slide Output Shaft with upper Bearing Cone into Housing.
3. Slide Lower Bearing Cone (#00748522) onto lower end of Output Shaft. Install Lower Bearing Cup (#00020600) over Output Shaft and into Main Housing.
4. Inspect Lower Bearing Cap (#00752155) at seal Area to be sure there are no Burrs or Scratches and if there are remove them. Install Output Seal (#00748519) into Lower Bearing Retainer Cap, Coat ID of Seal with a light coat of Grease.
5. Using Shims (#00748520) Install the Lower Bearing Retainer Cap use quantity of Shims as required to Set Bearing Pre-Load to 14 to 16 inch pounds of rolling torque, After Set remove bearing cap and coat Shims with Gasket Sealer reinstall & Check Bearing Pre-Load.
6. Go to the Top of the Output Shaft and install the Output Gear (#00755506) on top of shaft, This gear will sit on shaft without any holdown.
7. **Install Input Shaft**, You should already have inner Bearing Cup (#00748527) installed into back of Main Housing (#00752362). Take Input Shaft (#00752363) and install a Snap Ring (#00748526) in Groove near inner Bearing area. Install Another Snap Ring (#00748526) on Shaft at gear end. Note there are a number of grooves in Shaft for snap Rings, Make Sure they are installed in the correct grooves that they came out of.
8. With Gearbox Housing laying on its back drop the Inner Bearing Cone into Main Housing, Slide Input Shaft into Bearing.
9. **Gearbox 00752140/00752140A** Slide Input Gear (#00755506) onto Input Shaft, Slide Gear Spacer (#00748533) onto Input Shaft till it seats against gear. Slide Outer Input Bearing Cone (00748527) down over Input shaft. Gearbox 00752141 & 00752141A Gear, Spacer & Snap ring will install on Back Side of input Shaft to rear of main housing.
10. Inspect Bearing Cap (#00752365) for burrs or scratches at Seal area. If OK Install Outer Input shaft Bearing into Bearing Retaining Cap (#00752365), Install Input Seal (#00748536) into Bearing Cap. Coat ID of Seal with a light coat of grease, also coat input shaft where seal runs with light coat of grease.
11. Using Shims (#00748531) Slide Input Bearing retaining Cap down over Input Shaft, The number of shims required will vary. Tighten Bolts that hold Bearing Cap and Check Pre-load and Gear Back-Lash, Remove or add Shims as required. Bearing Pre-load should be 14 to 16 inch pounds of rolling torque. Gear Back-Lash should be .017" to .019", remove or add Shims as required.
12. When this has been Done fill Gearbox with Oil, Before deciding Gearbox is full wait long enough for Oil to run down between Output Shaft Bearing, Then refill with Oil, install Oil Plugs and check for leaks, After running Mower 1/2 to 1 hour check Oil Level and recheck for leaks.

NOTES

GEARBOX

P/N 00753190

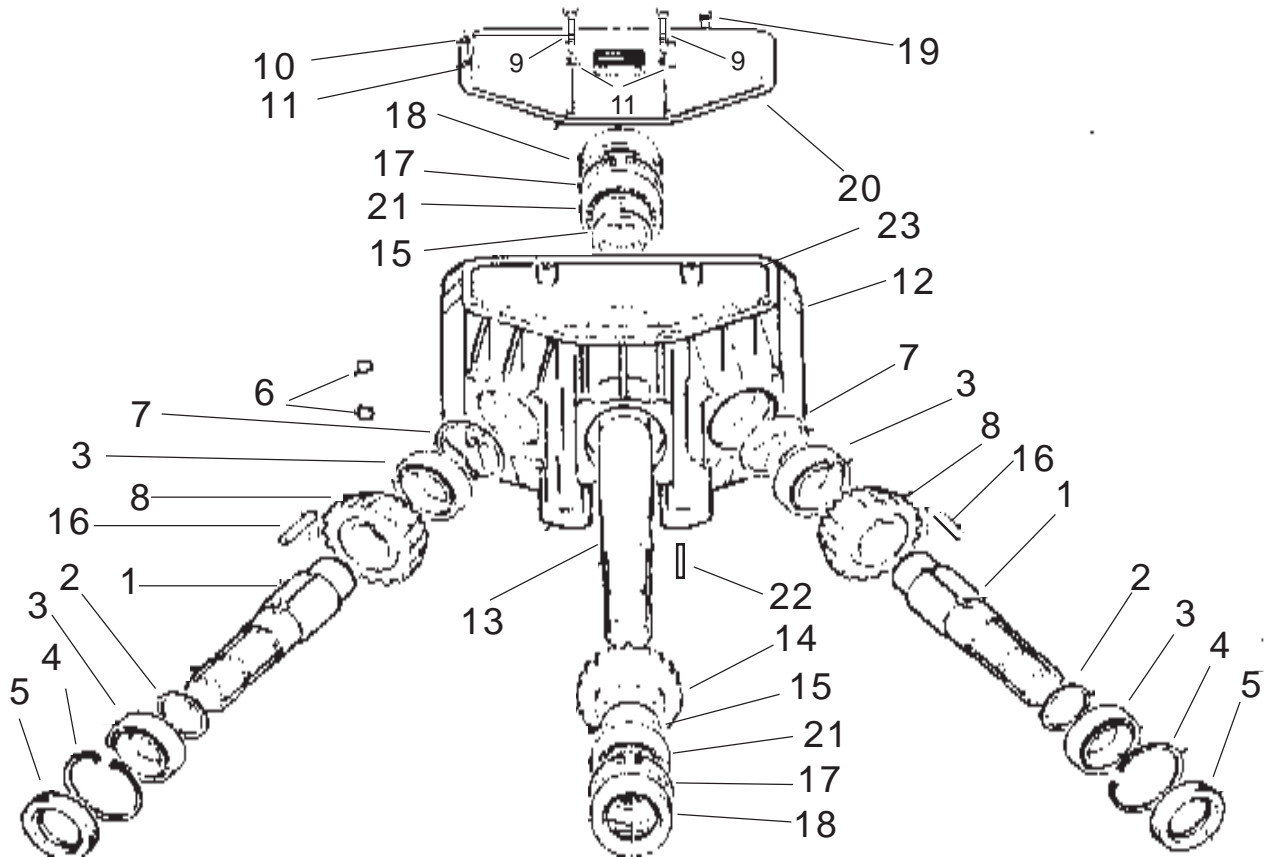

ITEM	PART NO.	QTY	DESCRIPTION
	00753190	-	Gearbox Asy (540 only)
1	00753221	2	Shaft (1-3/8" 6 Spline)
2	00753222	2	Washer
3	00753223	4	Bearing
4	00753224	2	Retaining Ring
5	00753225	2	Seal
6	00753226	2	Plug
7	00753227	2	Compensating Ring
8	00753228	2	Gear, 20 Tooth
9	00753229	2	Bolt
10	00753230	4	Bolt
11	00753231	6	Lockwasher
12	00753232	1	Housing, Main Gearbox Case
13	00753233	1	Shaft (1-3/8" 6 Spline)
14	00753234	1	Gear, 23 Tooth
15	00753235	2	Washer
16	00753236	2	Key
17	00753237	2	Retaining Ring
18	00753238	2	Seal
19	00753239	1	Plug, Breather
20	00753240	1	Cover, Top
21	00753241	2	Bearing
22	00753242	1	Key
23	00755069	1	Gasket, for Top cover

NOTE: This Gearbox has 1-3/8" 6 spline shafts, Is 540 RPM only, Has a Bolt on Top cover.

GEARBOX

P/N 00753190

Assembly Instructions

Installation Part Numbers are for Gearbox #00753190 (540 RPM)

1. Install Center Input / Output Shaft (item 13) , with Rear Bearings, Gear and componts as shown in Drawing into Main Housing (Item 12), install Input shaft before installing Output Shafts to Wings, Notice Item 15, these are compensating washer to keep end play out of Shaft. there may be one ore more used.
2. Install Snap Ring (Item 17) in Back of Housing (Item 12), this will retain Rear bearing (item 21) DO NOT INSTALL REAR SEAL YET. Install Front Spacer Washer (item 15) and front Bearing with its componts. , Install Front Snap Ring (Item 17) DO NOT INSTALL FRONT SEAL YET. Check Input shaft for End Play, If there is no end play Still DO NOT Install any seal at this time. Front and Rear Seal can be installed at this time, If there is end Play it may be required to remove or Add Washers (item # 15). IMPORTANT Rememer these are Ball Bearings and you DO NOT Pre-Load Ball Bearings.
3. Looking down into Gearbox Housing you will see casting part for Inner Bearing on Output Shafts to Wings. Install Inner Bearing (item 3) with Compensating Rings (item 7) as needed. put gear down into Housing, Insert Shaft from outside into housing. Insert Shims and outer Bearing (item 3). To set Backlash on gears it may be rquired to add or remove Compensating Rings (item7) to move Gear closer or further away from center Gear. The Gear Back lash should be .014" to .016" and shafts should NOT have End Play. Make sure of all parts install and gear Back Lash is correct, If Shaft has end Play but Back Lash is correct the end Play can be removed by adding or removing outer bearing washer (item 2). Both Side Drive Output Shafts will install the same way.
4. To Install Input and Output Seals into Main Housing. BEFORE installing Seals check Housing where seal installs to make sure the opening HAS NO burrs or scratches, The outer edge of opening can get sharp edges on it from installing the previous Seal. These sharp edges will cut outer edge of Seal, if these burrs or sharp edge are not removed Seals may leak, If this happens look for a group of scratches that run across the outer edge of seal when removed. To install the Seals it is best to use a Seal driver of the right size. Shaft area and inner ID of Seal should be coated with light coat of grease before installing.
5. Install top cover using Gasket or Gasket sealer, Fill Gearbox with oil. Gearbox can be filled with oil before top cover is installed if wanted. DO NOT Fill with Oil above Oil Level Plug. ALWAYS recheck Oil Level after running Mower 1/2 to 1 hour. Inspect Seals for leaking after filling with Oil and after running 1/2 to 1 hour.

GEARBOX

P/N 00754005

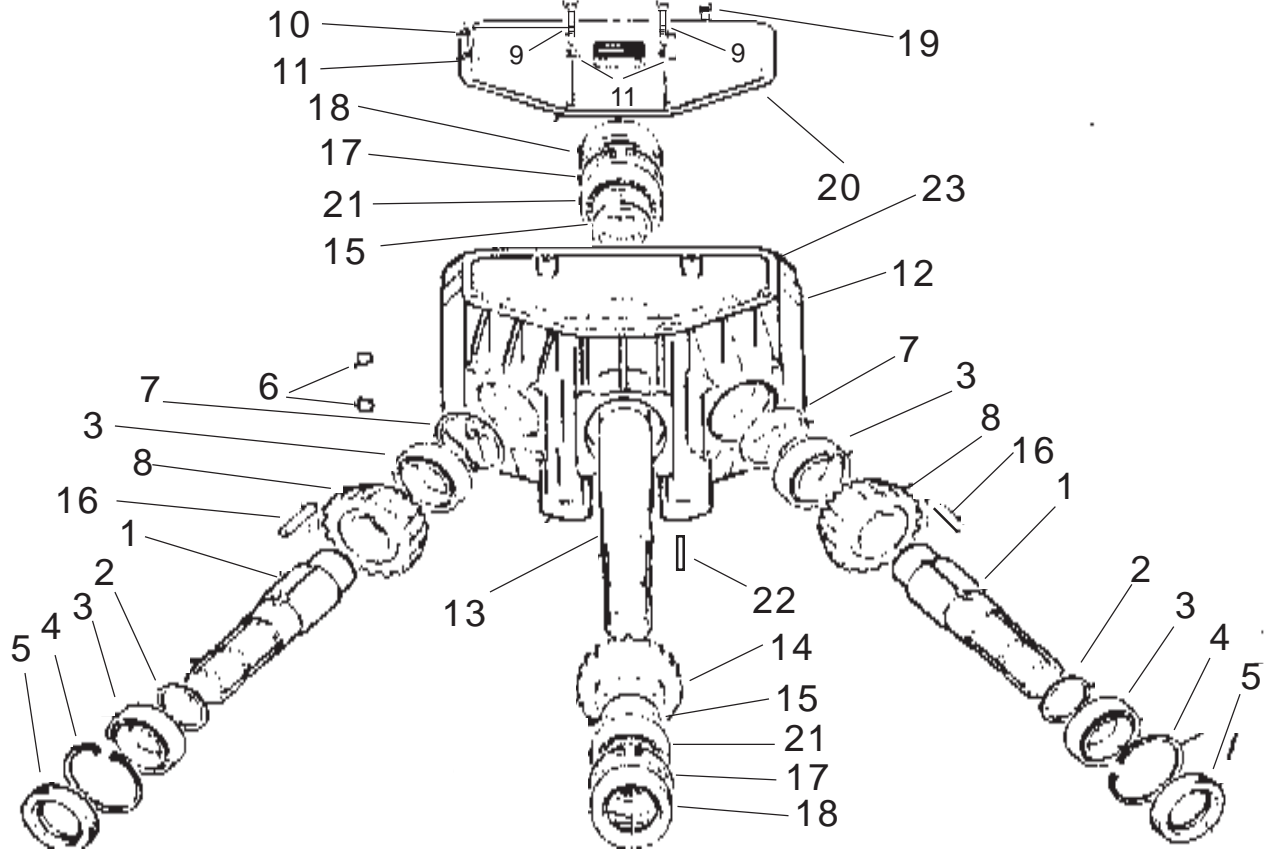

ITEM	PART NO.	QTY	DESCRIPTION
	00754005	-	Gearbox Asy (540 only)
1	00753221	2	Shaft (1-3/8" 6 Spline)
2	00753222	2	Washer
3	00753223	4	Bearing
4	00753224	2	Retaining Ring
5	00753225	2	Seal
6	00753226	2	Plug
7	00753227	2	Compensating Ring
8	00753228	2	Gear, 20 Tooth
9	00753229	2	Bolt
10	00753230	4	Bolt
11	00753231	6	Lockwasher
12	00753232	1	Housing, Main Gearbox Case
13	00753233	1	Shaft (1-3/8" 6 Spline)
14	00753234	1	Gear, 23 Tooth
15	00753235	2	Washer
16	00753236	2	Key
17	00753237	2	Retaining Ring
18	00753238	2	Seal
19	00753239	1	Plug, Breather
20	00753240	1	Cover, Top
21	00753241	2	Bearing
22	00753242	1	Key
23	00755069	1	Gasket, For Top Cover

NOTE: This Gearbox has 1-3/8" 6 spline shafts, Is 540 RPM only, Has a Bolt on Top cover.

GEARBOX

P/N 00754005

Assembly Instructions

1. Install Center Input / Output Shaft (item 13) , with Rear Bearings, Gear and componts as shown in Drawing into Main Housing (Item 12), install Input shaft before installing Output Shafts to Wings, Notice Item 15, these are compensating washer to keep end play out of Shaft. there may be one ore more used.
2. Install Snap Ring (Item 17) in Back of Housing (Item 12), this will retain Rear bearing (item 21) DO NOT INSTALL REAR SEAL YET. Install Front Spacer Washer (item 15) and front Bearing with its componts. , Install Front Snap Ring (Item 17) DO NOT INSTALL FRONT SEAL YET. Check Input shaft for End Play, If there is no end play Still DO NOT Install any seal at this time. Front and Rear Seal can be installed at this time, If there is end Play it may be required to remove or Add Washers (item # 15). IMPORTANT Rememer these are Ball Bearings and you DO NOT Pre-Load Ball Bearings.
3. Looking down into Gearbox Housing you will see casting part for Inner Bearing on Output Shafts to Wings. Install Inner Bearing (item 3) with Compensating Rings (item 7) as needed. put gear down into Housing, Insert Shaft from outside into housing. Insert Shims and outer Bearing (item 3). To set Backlash on gears it may be rquired to add or remove Compensating Rings (item7) to move Gear closer or further away from center Gear. The Gear Back lash should be .014" to .016" and shafts should NOT have End Play. Make sure of all parts install and gear Back Lash is correct, If Shaft has end Play but Back Lash is correct the end Play can be removed by adding or removing outer bearing washer (item 2). Both Side Drive Output Shafts will install the same way.
4. To Install Input and Output Seals into Main Housing. BEFORE installing Seals check Housing where seal installs to make sure the opening HAS NO burrs or scratches, The outer edge of opening can get sharp edges on it from installing the previous Seal. These sharp edges will cut outer edge of Seal, if these burrs or sharp edge are not removed Seals may leak, If this happens look for a group of scratches that run across the outer edge of seal when removed. To install the Seals it is best to use a Seal driver of the right size. Shaft area and inner ID of Seal should be coated with light coat of grease before installing.
5. Install top cover using Gasket or Gasket sealer, Fill Gearbox with oil. Gearbox can be filled with oil before top cover is installed if wanted. DO NOT Fill with Oil above Oil Level Plug. ALWAYS recheck Oil Level after running Mower 1/2 to 1 hour. Inspect Seals for leaking after filling with Oil and after running 1/2 to 1 hour.

Gearbox

P/N 00755566

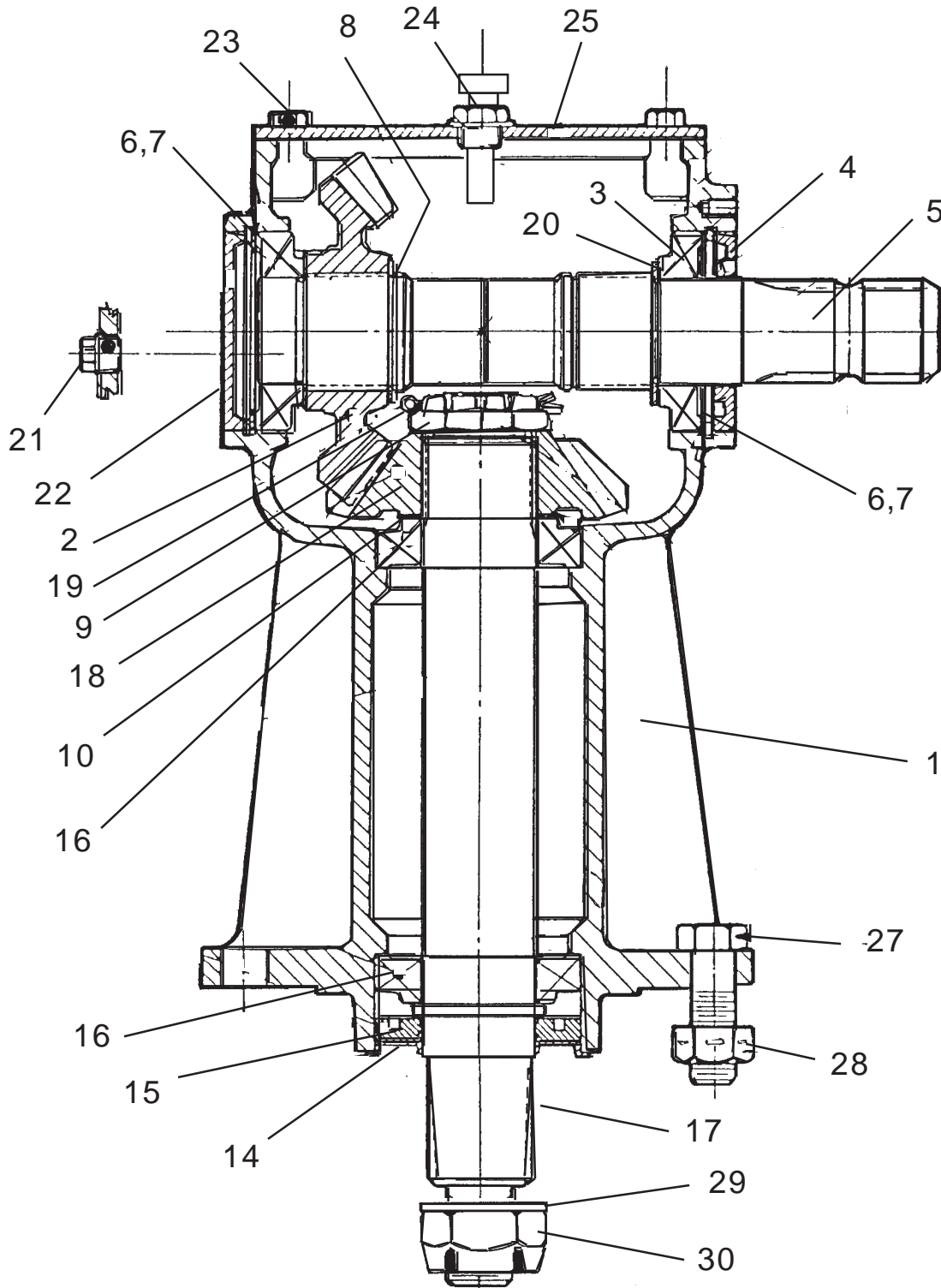

CW IN - CW OUT

Gearbox

P/N 00755566

Item	Part No.	Qty.	Description
	00755566	--	Gearbox Asy, (540 RPM)
1	00755613	1	Casing
2	00756899	1	Gear (24 Teeth-540RPM)
3	00755615	2	Bearing
4	00755616	1	Oil Seal
5	00755617	1	Shaft
6	00755618	2	Internal Circlip
7	00755619	2	Shim
8	00755620	1	External Circlip
9	00756943	1	Nut
10	00755622	1	Shim
14	00755626	1	Protective Shield
15	00755627	1	Oil Seal
16	00755628	2	Bearing
17	00755629	1	Shaft
18	00755630	1	Gear (16 Teeth-540 RPM)
19	00755631	1	Cotter Pin
20	00755632	1	Shim
21	00755633	1	Plug
22	00755634	1	Cap
23	00755635	4	Hex Bolt
24	00758654	1	Vent Plug
25	00755637	1	Cover
26	00755638	1	Shim
27	02880900	6	Bolt
28	00003901	6	Locknut
29	00037200	6	Nut
30	00755624	1	Nut, Castle
31	163016	1	Cotterpin, Blade Carrier
32	00755623	1	Washer f/ Blade carrier, Not Shown)

NOTE: This Gearbox has a Square Bolt on Top Cover & Input Gear is mounted in the Back as shown in drawing

Gearbox

P/N 00755566

Assembly Instructions

Gearbox Output Shaft Installation:

Installation Part Numbers are for Gearbox #00755566 (540 RPM)

- 1. Install Output Shaft** (Blade Shaft), Bearings, Gear in Main Housing (#00755613)
- Install Upper Bearing Cup (#00755628 Cup & Cone) into Main Housing (#00755613) from the top, Install Lower Bearing Cup (#00755628) into Main housing from the bottom.
- Install the Lower Bearing Cone (#00755628 Cup & Cone) down over Output Shaft. Insert Output Shaft with Bearing Cone on it up through Main Housing from the bottom. Put Upper Bearing Cone (#00755628 Cup & Cone) over Out Put Shaft and slide down till it bottoms out in upper Bearing Cup.
- Install Shims (#00755622) down over top of Output Shaft, The number of shims required will vary, try to use the same amount as were removed. Install Output Gear (#00755630) over Output Shaft, Make sure it is seated against Shim. Insert Shim (#00755638 washer) down against gear, Screw Slotted Bearing Adjusting Nut (#00756943) onto top of Out put Shaft.
- Tighten Bearing Adjusting Nut above Gear till Bearings have 14" to 16" pounds of rolling Torque then secure Bearing Adjusting Nut with Cotter Pin.
- DO NOT Install Output Seal (#00755627) now, wait till Input Shaft has been installed, When you do install it Coat ID of Seal with light coat of grease. Install Seal Protector (#00755626), this drives into lower Main Housing, This Seal Protector Should always be replaced with new one after being removed. Re-Check Bearing Pre-load. Output Shaft Should have NO end play and Bearing MUST be set at a rolling Torque. (See 5.)
- 7. Install Input Shaft**, Bearings and Gear into Main Housing (#00755613)
- Install External Clip (#00755620) on Input Shaft (#00755617) next to where Gear goes. Install External Clip (#00755632) on Input Shaft next to rear Bearing area. Drop Input Gear (#00756899) into Gearbox Main Housing from the top. Holding Gear inplace insert Input Shaft into Main Housing from the rear through rear Bearing opening on center and left wing Gearbox, from the front on Right wing Gearbox. Slide shaft guiding it through input Gear. slide Shaft in till External Clip is against Gear.
- Install Rear Input Bearing Cone (#00755615 Cup & Cone) into Rear of Main Housing till it is against External Clip on Shaft. Install Bearing Cup (#00755615 Cup & Cone) into rear of main housing, Install Shims (#00755619) in against Bearing Cup try to use the same amount of shims as were removed. Install Internal Clip (#00755618) into Main Housing against Shims. DO NOT install any Seals at this time. Install Front Bearing Cone (#00755615 Cup & Cone) onto Input Shaft from the front till they are against Input Gear. Install Shims against Bearing Cup, Install Internal Clip (#00755618) into front of Main Housing against Shims. DO NOT install any Seals at this time.
- Check Bearing Pre-Load (should be 14" to 16" pounds of rolling Torque) and Gear Back Lash between Blade Shaft Gear and Input Gear (should have .017" to .019" back Lash) If it is not correct, Add or remove shims from Input Shaft Bearings will change Bearing Pre-load, Move Shim from one side of input Bearing to other to Get Correct Back Lash, It may be required to add or remove shims from Blade Shaft output Gear to raise or lower it to get correct Back lash. Once all is correct Install Input Seal (#00755616) and Rear Seal Cap (#00755634) then recheck Gear and Bearing settings. Now is the time to install Output seal and lower seal protector, (see step 6).

Gearbox

P/N 00755566

Assembly Instructions

11. When this has been Done fill Gearbox with Oil, Before deciding Gearbox is full wait long enough for Oil to run down between Output Shaft Bearing, Then refill with Oil, install Top Cover (using Sealer for Gasket), Oil Plugs and check for leaks, After running Mower 1/2 to 1 hour check Oil Level and recheck for leaks.

NOTE: The Following Gearboxes will assemble the same as the above with very minor differences, some componet numbers and the location of the Input gear.

Gear Box #	RPM	Input Gear
00755598.....	540 rpm.....	Front
00755566.....	540 rpm.....	Rear
00756622.....	1000 rpm.....	Front
00756624.....	1000 rpm.....	Rear
00756739.....	1000 rpm.....	Front
00756741.....	1000 rpm.....	Rear
00756744.....	1000 rpm.....	Front
00760453.....	540 rpm.....	Front

Gearbox P/N 00755598

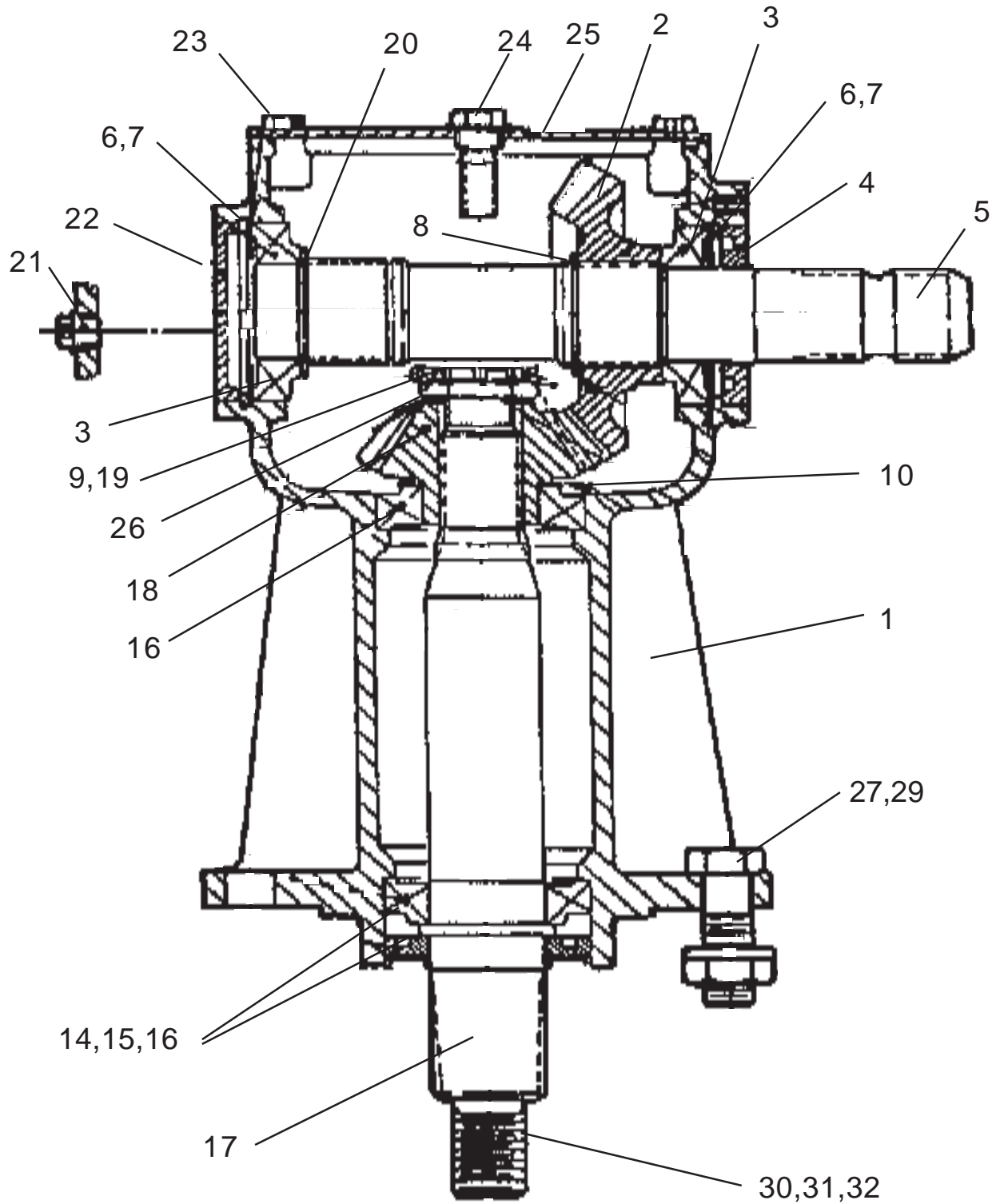

Gearbox

P/N 00755598

Item	Part No.	Qty	Description
	00755598	--	Gearbox Asy, (540 RPM)
1	00755613	1	Gearbox Housing, Main
2	00755614	1	Gear, 24 Tooth (540 RPM)
3	00755615	2	Bearing
4	00755616	1	Seal
5	00755617	1	Shaft, Input
6	00755618	2	Circlip, Internal
7	00755619	2	Shim, 012 (a/r)
	00756198	2	Shim, 016 (a/r)
8	00755620	1	Circlip, External
9	00755621	1	Nut, Slotted, Brg Adjusting
10	00755622	1	Shim, .020 (a/r)
14	00755626	1	Seal, Protector
15	00755627	1	Seal
16	00755628	2	Bearing
17	00755629	1	Shaft, Output
18	00755630	1	Gear, 16 Tooth (540 RPM)
19	00756946	1	Cotter Pin
20	00755632	1	Shim
21	00755633	1	Plug, Oil Level Check
22	00755634	1	Seal Cap, Rear
23	00755635	4	Bolt
24	00757342	1	Plug, Vent / Oil Fill
25	00755637	1	Cover, Top
26	00755638	1	Shim, .040 (a/r)
27	02880900	6	Bolt
28	00003901	6	Lockwasher
29	00037200	6	Nut
30	00755624	1	Nut, Blade Carrier Retaining (Not Shown)
31	00755623	1	Washer, Blade Carrier (Not Shown)
32	00606000	1	Cotterpin, Blade Carrier (Not Shown)

NOTE: This Gearbox has a Square Bolt on Top Cover & Input Gear is mounted in the front as shown in drawing

Gearbox

P/N 00755598

Assembly Instructions

Installation Part Numbers are for Gearbox #00755598 (540 RPM)

- 1. Install Output Shaft** (Blade Shaft), Bearings, Gear in Main Housing (#00755613)
- Install Upper Bearing Cup (#00755628 Cup & Cone) into Main Housing (#00755613) from the top, Install Lower Bearing Cup (#00755628) into Main housing from the bottom.
- Install the Lower Bearing Cone (#00755628 Cup & Cone) down over Output Shaft. Insert Output Shaft with Bearing Cone on it up through Main Housing from the bottom. Put Upper Bearing Cone (#00755628 Cup & Cone) over Out Put Shaft and slide down till it bottoms out in upper Bearing Cup.
- Install Shims (#00755622) down over top of Output Shaft, The number of shims required will vary, try to use the same amount as were removed. Install Output Gear (#00755630) over Output Shaft, Make sure it is seated against Shim. Insert Shim (#00755638 washer) down against gear, Screw Slotted Bearing Adjusting Nut (#00755621) onto top of Out put Shaft.
- Tighten Bearing Adjusting Nut above Gear till Bearings have 14" to 16" pounds of rolling Torque then secure Bearing Adjusting Nut with Cotter Pin.
- DO NOT Install Output Seal (#00755627) now, wait till Input Shaft has been installed, When you do install it Coat ID of Seal with light coat of grease. Install Seal Protector (#00755626), this drives into lower Main Housing, This Seal Protector Should always be replaced with new one after being removed. Re-Check Bearing Pre-load. Output Shaft Should have NO end play and Bearing MUST be set at a rolling Torque. (See 5.)
- 7. Install Input Shaft**, Bearings and Gear into Main Housing (#00755613)
- Install External Clip (#00755620) on Input Shaft (#00755617) next to where Gear goes. Install External Clip (#00755632) on Input Shaft next to rear Bearing area. Drop Input Gear (#00755614) into Gearbox Main Housing from the top. Holding Gear in place insert Input Shaft into Main Housing from the rear through rear Bearing opening on center and left wing Gearbox, from the front on Right wing Gearbox. Slide shaft guiding it through input Gear. slide Shaft in till External Clip is against Gear.
- Install Rear Input Bearing Cone (#00755615 Cup & Cone) into Rear of Main Housing till it is against External Clip on Shaft. Install Bearing Cup (#00755615 Cup & Cone) into rear of main housing, Install Shims (#00755619) in against Bearing Cup try to use the same amount of shims as were removed. Install Internal Clip (#00755618) into Main Housing against Shims. DO NOT install any Seals at this time. Install Front Bearing Cone (#00755615 Cup & Cone) onto Input Shaft from the front till they are against Input Gear. Install Shims against Bearing Cup, Install Internal Clip (#00755618) into front of Main Housing against Shims. DO NOT install any Seals at this time.
- Check Bearing Pre-Load (should be 14" to 16" pounds of rolling Torque) and Gear Back Lash between Blade Shaft Gear and Input Gear (should have .017" to .019" back Lash) If it is not correct, Add or remove shims from Input Shaft Bearings will change Bearing Pre-load, Move Shim from one side of input Bearing to other to Get Correct Back Lash, It may be required to add or remove shims from Blade Shaft output Gear to raise or lower it to get correct Back lash. Once all is correct Install Input Seal (#00755616) and Rear Seal Cap (#00755634) then recheck Gear and Bearing settings. Now is the time to install Output seal and lower seal protector, (see step 6).

Gearbox

P/N 00755598

Assembly Instructions

11. When this has been Done fill Gearbox with Oil, Before deciding Gearbox is full wait long enough for Oil to run down between Output Shaft Bearing, Then refill with Oil, install Top Cover (using Sealer for Gasket), Oil Plugs and check for leaks, After running Mower 1/2 to 1 hour check Oil Level and recheck for leaks.

NOTE: The Following Gearboxes will assemble the same as the above with very minor differences, some componet numbers and the location of the Input gear.

Gear Box #	RPM	Input Gear
00755598.....	540 rpm.....	Front
00755566.....	540 rpm.....	Rear
00756622.....	1000 rpm.....	Front
00756624.....	1000 rpm.....	Rear
00756739.....	1000 rpm.....	Front
00756741.....	1000 rpm.....	Rear
00756744.....	1000 rpm.....	Front
00760453.....	540 rpm.....	Front

GEARBOX P/N 00755697A

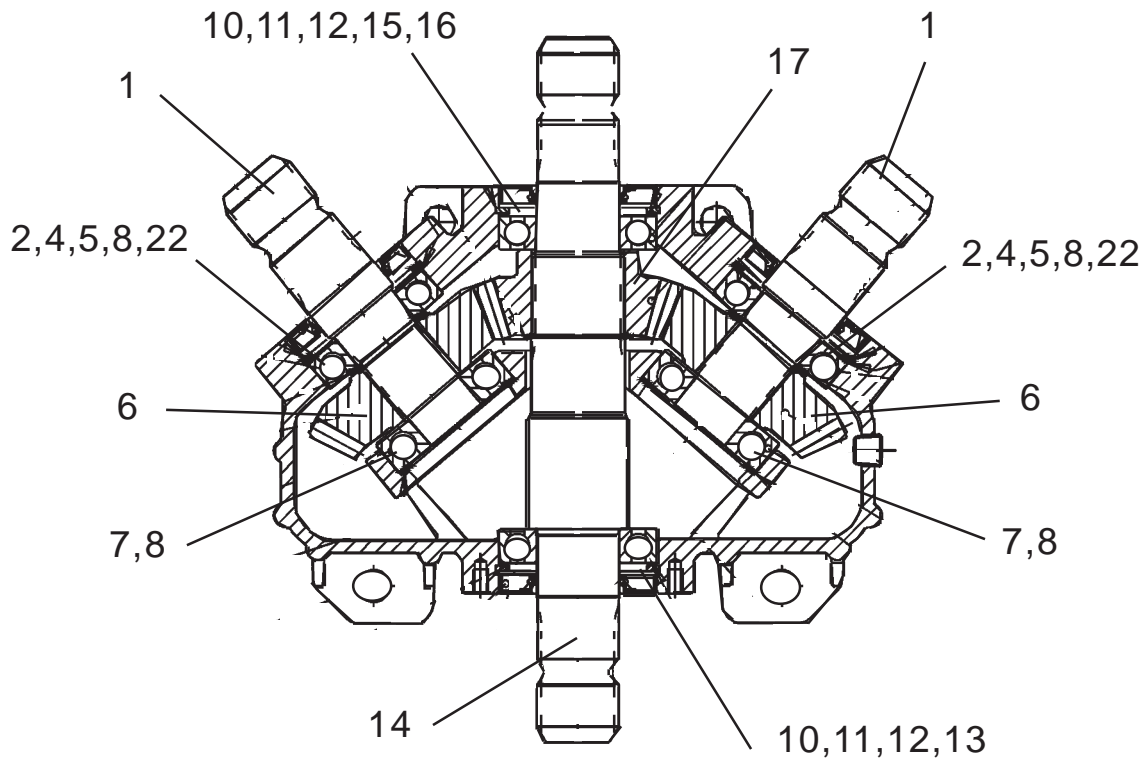
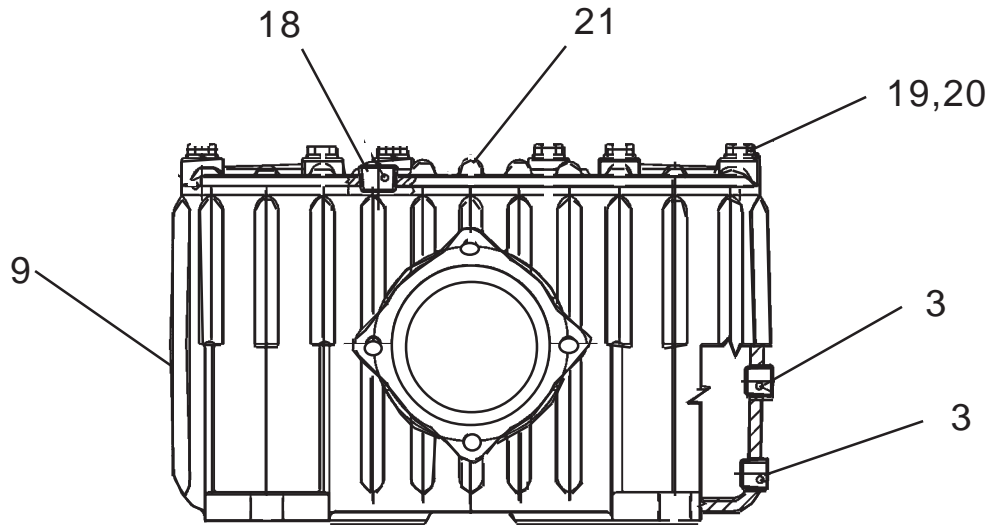

GEARBOX

P/N 00755697A

Item	Part No.	Qty.	Description
	00755697A	-	Gearbox Asy. Divider 1000 RPM
1	00756643	2	Shaft 1-3/4" X 20 Spline
2	00756644	2	Oil Seal
3	00753226	2	Plug
4	00753224	2	Snap Ring Lining
5	00563700	2	Bearing
6	00772981	2	Gear, 24 tooth (1000 RPM)
7	00753223	2	Bearing
8	00756645	4	Shim
9	00753232	1	Casing
10	00753237	2	Snap Ring Lining
11	00753238	2	Oil Seal
12	2716406	2	Shim
13	00753241	1	Bearing
14	00756648	1	Shaft 1-3/4" X 20 Spline
15	00755068	1	Snap Ring
16	00753241	1	Bearing
17	00772982	1	Gear, 20 Tooth (1000 RPM)
18	2716590	1	Plug
19	00753231	6	Spring Washer
20	00753230	6	Bolt
21	00753240	1	Cover, Top
22	00756649	2	Snap Ring Lining

GEARBOX

P/N 00755697A

Assembly Instructions

Installation Part Numbers are for Gearbox #00755697A (1000 RPM)

- 1. Install Center Input / Output Shaft** (item 14) , with Bearings, Gear and components as shown in Drawing into Main Housing (Item 9), install Input shaft before installing Output Shafts to Wings, Notice Item 12, these are Shim Washers (Compensating Rings) to keep end play out of Shaft. there may be one ore more used. **DO NOT INSTALL ANY SEALS TILL GEARBOX IS COMPLETELY ASSEMBLED !** Before you install the seals check the openings for burrs or scratches that will damage or prevent the OD of the seal from sealing. Remove any Burrs and fill scratch with good gasket Sealer
- 2. Install Snap Ring** (Item 10) in Back of Housing (Item 9), this will retain Rear bearing (item 16) **DO NOT** install Rear Seal (item 11) at this time. Install Front Shims (item 12), Qty use same as was removed as this amount can vary. Slide rear Bearing (item 16) into housing (item 9) this can be done from inside. Push Bearing in till it seats against the Shims & Snap Ring (items 10 & 12).
- 3. Holding Input Gear** (item 17) into Gearbox Housing (item 9) from the top slide the Input Shaft (item 14) into the Housing from the front. Slide Shaft through Gear and Rear Bearing.
- 4. Install Front Bearing** (item 13) on input Shaft from the front. Slide Bearing till it goes into Geabox Housing and seats against Shoulder on Input Shaft. Install Shims (item 12) using quantity that will will allow end play to be removed, This is a trial & error method because you will need to install Snap Ring (item 10) to check then remove it to add or remove Shims. These are ball Bearings so they will not have Pre-Load. **DO NOT** install Front Seal (item 11) at this time.
- 5. Install Output Shaft to Side Drives**, The Left & Right Shafts will install the Same using the same Part Numbers. it is best to install Parts for both Side Drive Shafts at same time.
- 6. Looking down into gearbox Housing** (item 9) you can see the inner casting for the Inner Bearing (item 7), There will be adjusting Shims (item 8) that need to be installed here before Bearing is. The quantity of Shims will vary, Try the same amount as was removed here. Install the inner Bearing (item 7) into Housing.
- 7. Side Output Shaft** (item 1) has a Snap Ring Grove on it near outer Bearing (item 5)area. Slide Outer Bearing (item 5) onto Side Shaft (item 1) till it seats against Shoulder on Shaft. Install Snap Ring (item 22) on Shaft next to Bearing.
- 8. Take the Gear for Side Drive** (item 6) and slide it down into Gearbox from the Top, With the side Drive Gear in position against the Input Gear (item 17), take the Side drive Shaft (item 1) and Slide it through the Housing from the out side, rotating Shaft as you push it through to align Splines on shaft with spline in Gear. Push the Shaft in till the Bearing is into Housing and the shoulder on Shaft seats against inner Bearing.

GEARBOX

P/N 00755697A

Assembly Instructions

- 9.** From the outside install Shims in against Outer Bearing, use quantity to remove end play, install Snap Ring (item 4) to retain Components of Side Out put Shaft. DO NOT install Seals at this time.
- 10.** it is now time to check Gear Back-Lash and Seating of gears Heal to Toe, The Back-Lash and Seating of gears can be changed by moving Shims (item 12) on center Shaft and (item 8) on Side Drive Shafts. this is a trial & error Method of adding & removing Shims. Do This till the Gear Back Lash is .016" to .019" and Gear seating is even Heal to Toe.
- 11.** Coat all Shafts & ID of seals with a light coat of Grease before installing Seals. Install Seals Now, if the openings for the seals have not been inspected as explained in Step 1, do so now before installing Seals.
- 12.** Install top cover using Gasket sealer, Fill Gearbox with oil. Gearbox can be filled with oil before top cover is installed if wanted. DO NOT Fill with Oil above Oil Level Plug. Always check for Oil Leaks before Running Mower and Always recheck Oil Level, Inspect Seals for Leaking, Excessive end play in Shaft after running Mower 1/2 to 1 hour

Gearbox

P/N 00755698

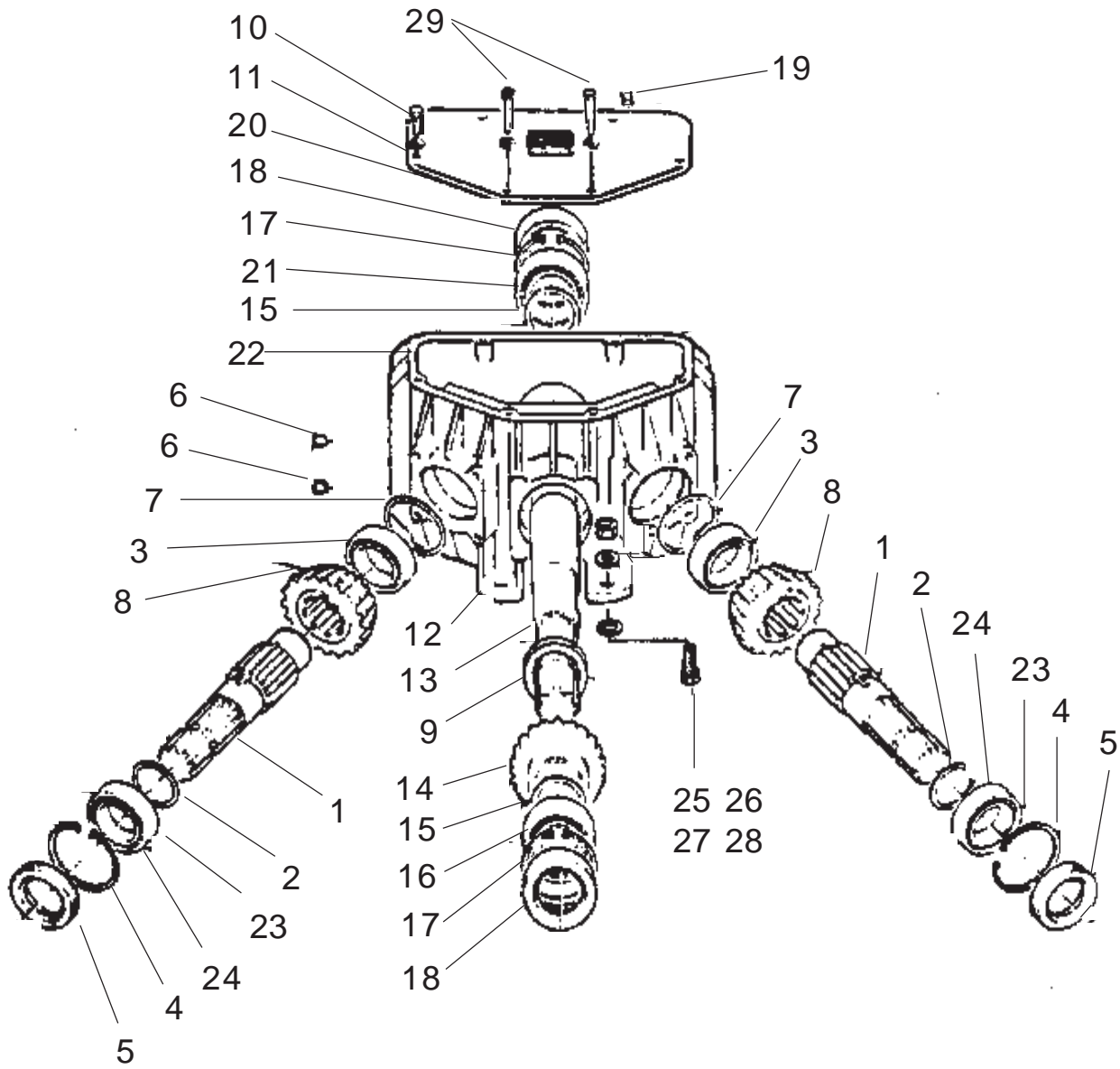

Gearbox

P/N 00755698

Item	Part No.	Qty	Description
	00755698	1	Gearbox Asy, (1000 RPM)
1	00756643	2	Shaft
2	00756647	2	Shim
3	00753223	2	Bearing
4	00753224	2	Retaining Ring
5	00756644	2	Oil Seal
6	00753226	2	Oil Plug
7	00756645	2	Shim
8	00755746	2	Gear, 25 Tooth, (1000 RPM)
9	00755068	1	Retaining Ring
10	00753230	4	Capscrew
11	00753231	6	Spring Washer
12	00753232	1	Housing
13	00756648	1	Shaft
14	00755745	1	Gear, 19 Tooth, (1000 RPM)
15	00753235	2	Shim
16	00755070	1	Bearing, Front
17	00753237	2	Retaining Ring
18	00753238	2	Oil Seal
19	00753239	1	Breather Plug
20	00753240	1	Top Cover
21	00753241	1	Bearing, Rear
22	00755069	1	Gasket
23	00756649	2	Retaining Ring
24	00756646	2	Bearing
25	00001400	4	Flatwasher
26	02845500	4	Bolt
27	00010300	4	Lockwasher
28	00010400	4	Nut

GEARBOX

P/N 00755698

Assembly Instructions

1. Install Center Input / Output Shaft (item 13) , with Rear Bearings, Gear and componts as shown in Drawing into Main Housing (Item 12), install Input shaft before installing Output Shafts to Wings, Notice Item 15, these are compensating washer to keep end play out of Shaft. there may be one ore more used.
2. Install Snap Ring (Item 17) in Back of Housing (Item 12), this will retain Rear bearing (item 21) DO NOT INSTALL REAR SEAL YET. Install Front Spacer Washer (item 15) and front Bearing with its componts. , Install Front Snap Ring (Item 17) DO NOT INSTALL FRONT SEAL YET. Check Input shaft for End Play, If there is no end play Still DO NOT Install any seal at this time. Front and Rear Seal can be installed at this time, If there is end Play it may be required to remove or Add Washers (item # 15). IMPORTANT Rememer these are Ball Bearings and you DO NOT Pre-Load Ball Bearings.
3. Looking down into Gearbox Housing you will see casting part for Inner Bearing on Output Shafts to Wings. Install Inner Bearing (item 3) with Compensating Rings (item 7) as needed. put gear down into Housing, Insert Shaft from outside into housing. Insert Shims and outer Bearing (item 3). To set Backlash on gears it may be required to add or remove Compensating Rings (item7) to move Gear closer or further away from center Gear. The Gear Back lash should be .014" to .016" and shafts should NOT have End Play. Make sure of all parts install and gear Back Lash is correct, If Shaft has end Play but Back Lash is correct the end Play can be removed by adding or removing outer bearing washer (item 2). Both Side Drive Output Shafts will install the same way.
4. To Install Input and Output Seals into Main Housing. BEFORE installing Seals check Housing where seal installs to make sure the opening HAS NO burrs or scratches, The outer edge of opening can get sharp edges on it from installing the previous Seal. These sharp edges will cut outer edge of Seal, if these burrs or sharp edge are not removed Seals may leak, If this happens look for a group of scratches that run across the outer edge of seal when removed. To install the Seals it is best to use a Seal driver of the right size. Shaft area and inner ID of Seal should be coated with light coat of grease before installing.
5. Install top cover using Gasket or Gasket sealer, Fill Gearbox with oil. Gearbox can be filled with oil before top cover is installed if wanted. DO NOT Fill with Oil above Oil Level Plug. ALWAYS recheck Oil Level after running Mower 1/2 to 1 hour. Inspect Seals for leaking after filling with Oil and after running 1/2 to 1 hour.

NOTES

GEARBOX P/N 00756603A

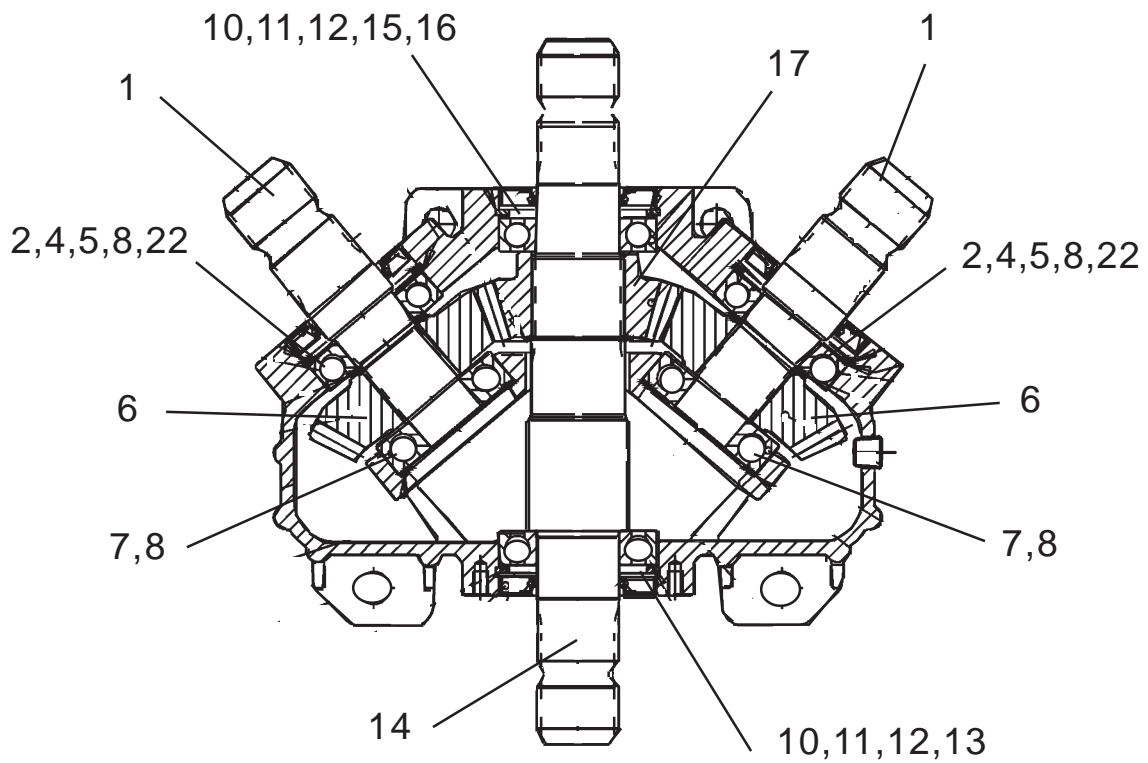
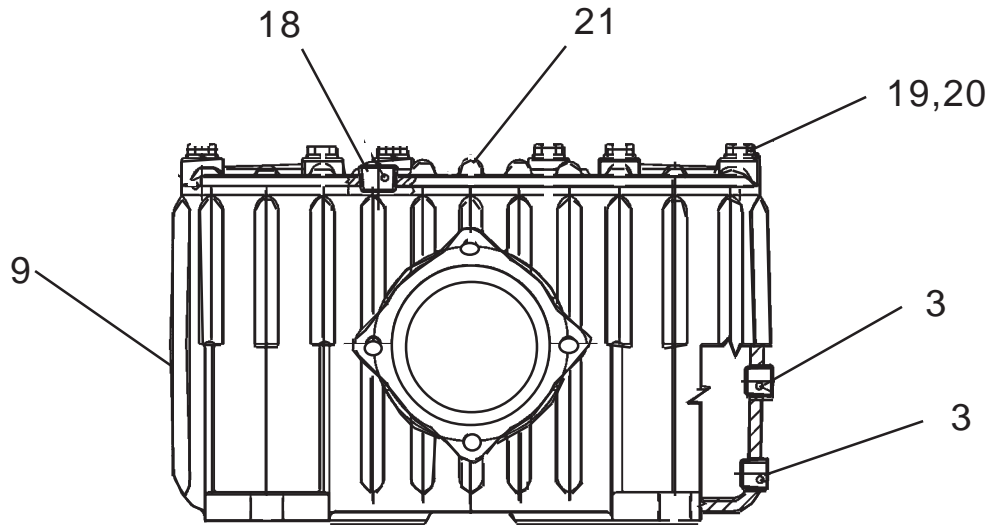

GEARBOX

P/N 00756603A

Item	Part No.	Qty.	Description
	00756603A	-	Gearbox Asy. Divider (540 RPM)
1	00756643	2	Shaft 1-3/4" X 20 Spline
2	00756644	2	Oil Seal
3	00753226	2	Plug
4	00753224	2	Snap Ring Lining
5	00563700	2	Bearing
6	00772983	2	Gear, 20 Tooth (1000 RPM)
7	00753223	2	Bearing
8	00756645	4	Shim
9	00753232	1	Casing
10	00753237	2	Snap Ring Lining
11	00753238	2	Oil Seal
12	2716406	2	Shim
13	00753241	1	Bearing
14	00756648	1	Shaft 1-3/4" X 20 Spline
15	00755068	1	Snap Ring
16	00753241	1	Bearing
17	00772984	1	Gear, 24 Tooth (1000 RPM)
18	2716590	1	Plug
19	00753231	6	Spring Washer
20	00753230	6	Bolt
21	00753240	1	Cover, Top
22	00756649	2	Snap Ring Lining

GEARBOX

P/N 00756603A

Assembly Instructions

Installation Part Numbers are for Gearbox #00756603A (540 RPM)

- 1. Install Center Input / Output Shaft** (item 14) , with Bearings, Gear and components as shown in Drawing into Main Housing (Item 9), install Input shaft before installing Output Shafts to Wings, Notice Item 12, these are Shim Washers (Compensating Rings) to keep end play out of Shaft. there may be one ore more used. **DO NOT INSTALL ANY SEALS TILL GEARBOX IS COMPLETELY ASSEMBLED !** Before you install the seals check the openings for burrs or scratches that will damage or prevent the OD of the seal from sealing. Remove any Burrs and fill scratch with good gasket Sealer
- 2. Install Snap Ring** (Item 10) in Back of Housing (Item 9), this will retain Rear bearing (item 16) **DO NOT** install Rear Seal (item 11) at this time. Install Front Shims (item 12), Qty use same as was removed as this amount can vary. Slide rear Bearing (item 16) into housing (item 9) this can be done from inside. Push Bearing in till it seats against the Shims & Snap Ring (items 10 & 12).
- 3. Holding Input Gear** (item 17) into Gearbox Housing (item 9) from the top slide the Input Shaft (item 14) into the Housing from the front. Slide Shaft through Gear and Rear Bearing.
- 4. Install Front Bearing** (item 13) on input Shaft from the front. Slide Bearing till it goes into Geabox Housing and seats against Shoulder on Input Shaft. Install Shims (item 12) using quantity that will will allow end play to be removed, This is a trial & error method because you will need to install Snap Ring (item 10) to check then remove it to add or remove Shims. These are ball Bearings so they will not have Pre-Load. **DO NOT** install Front Seal (item 11) at this time.
- 5. Install Output Shaft to Side Drives**, The Left & Right Shafts will install the Same using the same Part Numbers. it is best to install Parts for both Side Drive Shafts at same time.
- 6. Looking down into gearbox Housing** (item 9) you can see the inner casting for the Inner Bearing (item 7), There will be adjusting Shims (item 8) that need to be installed here before Bearing is. The quantity of Shims will vary, Try the same amount as was removed here. Install the inner Bearing (item 7) into Housing.
- 7. Side Output Shaft** (item 1) has a Snap Ring Grove on it near outer Bearing (item 5)area. Slide Outer Bearing (item 5) onto Side Shaft (item 1) till it seats against Shoulder on Shaft. Install Snap Ring (item 22) on Shaft next to Bearing.
- 8. Take the Gear for Side Drive** (item 6) and slide it down into Gearbox from the Top, With the side Drive Gear in position against the Input Gear (item 17), take the Side drive Shaft (item 1) and Slide it through the Housing from the out side, rotating Shaft as you push it through to align Splines on shaft with spline in Gear. Push the Shaft in till the Bearing is into Housing and the shoulder on Shaft seats against inner Bearing.

GEARBOX

P/N 00756603A

Assembly Instructions

- 9.** From the outside install Shims in against Outer Bearing, use quantity to remove end play, install Snap Ring (item 4) to retain Components of Side Out put Shaft. **DO NOT** install Seals at this time.
- 10.** it is now time to check Gear Back-Lash and Seating of gears Heal to Toe, The Back-Lash and Seating of gears can be changed by moving Shims (item 12) on center Shaft and (item 8) on Side Drive Shafts. this is a trial & error Method of adding & removing Shims. Do This till the Gear Back Lash is .016" to .019" and Gear seating is even Heal to Toe.
- 11.** Coat all Shafts & ID of seals with a light coat of Grease before installing Seals. Install Seals Now, if the openings for the seals have not been inspected as explained in Step 1, do so now before installing Seals.
- 12.** Install top cover using Gasket sealer, Fill Gearbox with oil. Gearbox can be filled with oil before top cover is installed if wanted. **DO NOT** Fill with Oil above Oil Level Plug. Always check for Oil Leaks before Running Mower and Always recheck Oil Level, Inspect Seals for Leaking, Excessive end play in Shaft after running Mower 1/2 to 1 hour

Gearbox

P/N 00756604

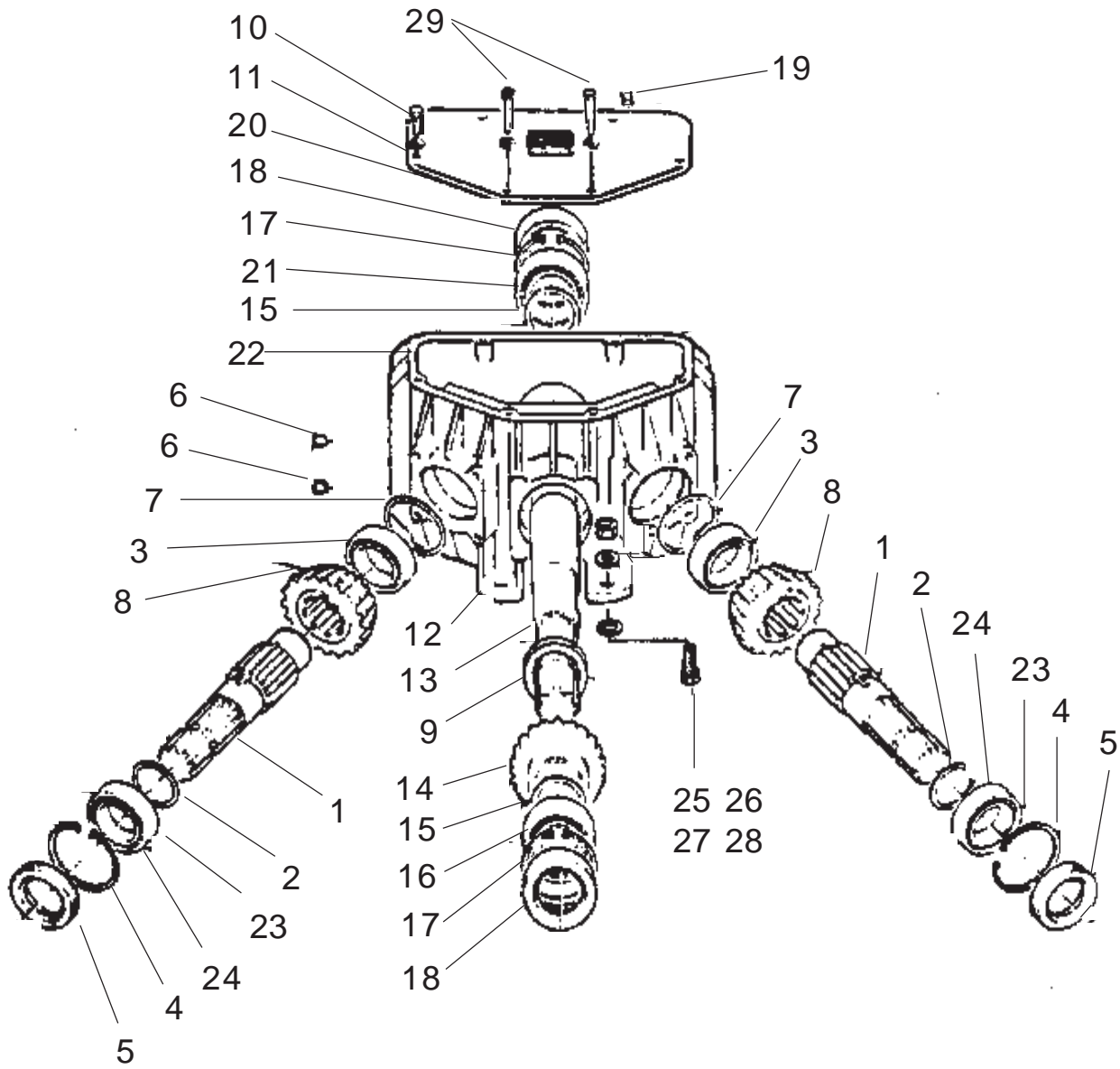

Gearbox

P/N 00756604

Item	Part No.	Qty	Description
	00756604	1	Gearbox Asy, (540 RPM)
1	00756643	2	Shaft
2	00756647	2	Shim
3	00753223	2	Bearing
4	00753224	2	Retaining Ring
5	00756644	2	Oil Seal
6	00753226	2	Oil Plug
7	00756645	2	Shim
8	00753228	2	Gear, 20 Tooth, (540 RPM)
9	00755068	1	Retaining Ring
10	00753230	4	Capscrew
11	00753231	6	Spring Washer
12	00753232	1	Housing
13	00756648	1	Shaft
14	00753234	1	Gear, 23 Tooth, (540 RPM)
15	00753235	2	Shim
16	00755070	1	Bearing, Front
17	00753237	2	Retaining Ring
18	00753238	2	Oil Seal
19	00753239	1	Breather Plug
20	00753240	1	Top Cover
21	00753241	1	Bearing, Rear
22	00755069	1	Gasket
23	00756649	2	Retaining Ring
24	00756646	2	Bearing
25	00001400	4	Flatwasher
26	02845500	4	Bolt
27	00010300	4	Lockwasher
28	00010400	4	Nut

GEARBOX

P/N 00756604

Assembly Instructions

1. Install Center Input / Output Shaft (item 13) , with Rear Bearings, Gear and componts as shown in Drawing into Main Housing (Item 12), install Input shaft before installing Output Shafts to Wings, Notice Item 15, these are compensating washer to keep end play out of Shaft. there may be one ore more used.
2. Install Snap Ring (Item 17) in Back of Housing (Item 12), this will retain Rear bearing (item 21) DO NOT INSTALL REAR SEAL YET. Install Front Spacer Washer (item 15) and front Bearing with its componts. , Install Front Snap Ring (Item 17) DO NOT INSTALL FRONT SEAL YET. Check Input shaft for End Play, If there is no end play Still DO NOT Install any seal at this time. Front and Rear Seal can be installed at this time, If there is end Play it may be required to remove or Add Washers (item # 15). IMPORTANT Rememer these are Ball Bearings and you DO NOT Pre-Load Ball Bearings.
3. Looking down into Gearbox Housing you will see casting part for Inner Bearing on Output Shafts to Wings. Install Inner Bearing (item 3) with Compensating Rings (item 7) as needed. put gear down into Housing, Insert Shaft from outside into housing. Insert Shims and outer Bearing (item 3). To set Backlash on gears it may be required to add or remove Compensating Rings (item7) to move Gear closer or further away from center Gear. The Gear Back lash should be .014" to .016" and shafts should NOT have End Play. Make sure of all parts install and gear Back Lash is correct, If Shaft has end Play but Back Lash is correct the end Play can be removed by adding or removing outer bearing washer (item 2). Both Side Drive Output Shafts will install the same way.
4. To Install Input and Output Seals into Main Housing. BEFORE installing Seals check Housing where seal installs to make sure the opening HAS NO burrs or scratches, The outer edge of opening can get sharp edges on it from installing the previous Seal. These sharp edges will cut outer edge of Seal, if these burrs or sharp edge are not removed Seals may leak, If this happens look for a group of scratches that run across the outer edge of seal when removed. To install the Seals it is best to use a Seal driver of the right size. Shaft area and inner ID of Seal should be coated with light coat of grease before installing.
5. Install top cover using Gasket or Gasket sealer, Fill Gearbox with oil. Gearbox can be filled with oil before top cover is installed if wanted. DO NOT Fill with Oil above Oil Level Plug. ALWAYS recheck Oil Level after running Mower 1/2 to 1 hour. Inspect Seals for leaking after filling with Oil and after running 1/2 to 1 hour.

NOTES

Gearbox

P/N 00756622

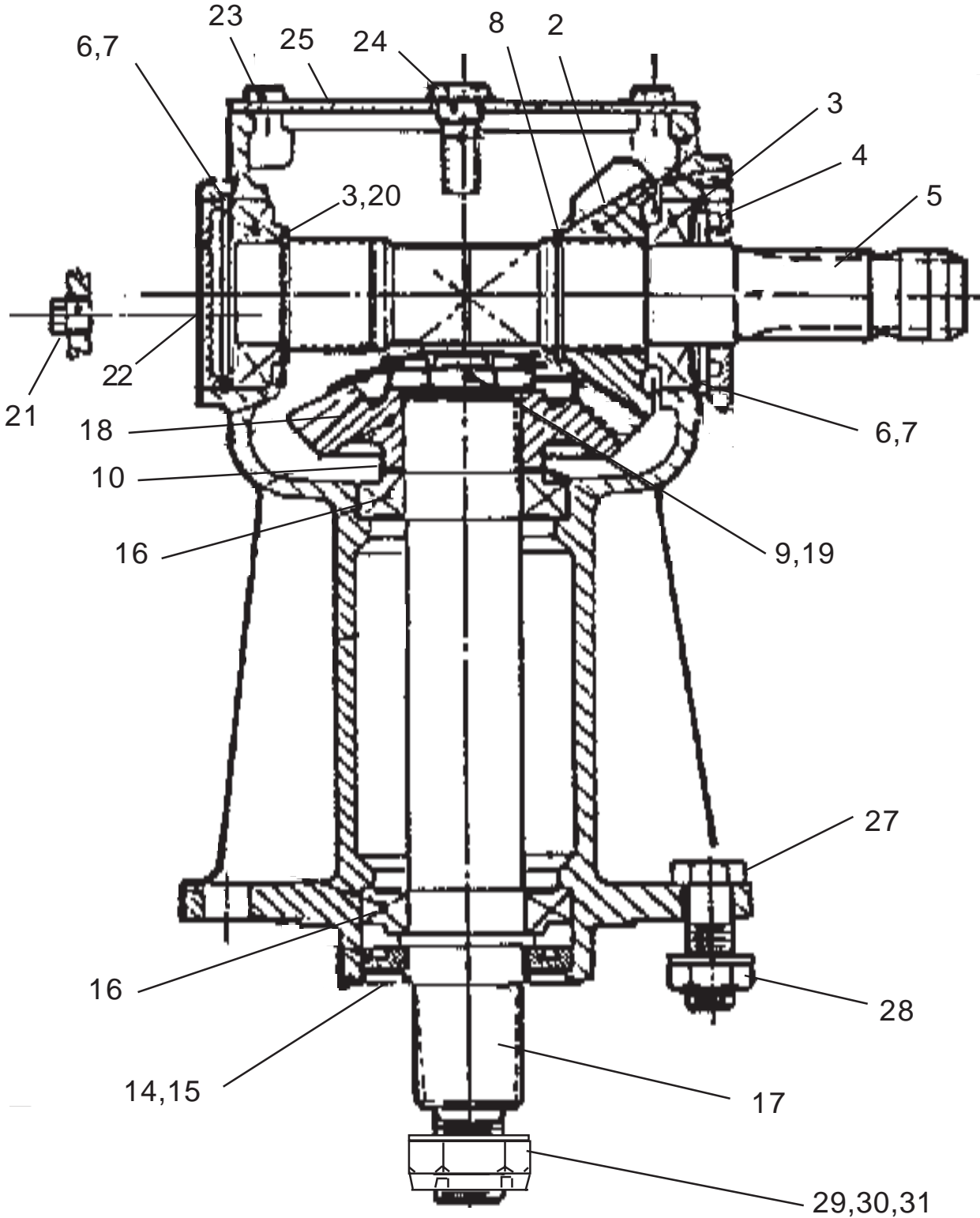

Note: Blades Turn CCW

Gearbox

P/N 00756622

P/N 00756622 (1000 RPM) CW IN - CCW OUT

Item	Part No.	Qty	Description
	00756622	--	Gearbox Asy. (1000 RPM)
1	00755613	1	Gearbox Housing, Main
2	00756900	1	Gear, 1000 RPM Input (20 Tooth)
3	00755615	2	Bearing
4	00753238	1	Seal
5	00755617	1	Shaft, Input
6	00755618	2	Circlip, Internal
7	00755619	2	Shim
8	00755620	1	Circlip, External
9	00756943	1	Nut, Slotted
10	00755622	1	Shim
14	00755626	1	Shield, Protective
15	00755627	1	Seal
16	00755628	2	Bearing
17	00756945	1	Shaft, Output
18	00756899	1	Gear, 1000 RPM Output (24 Tooth)
19	00756946	1	Cotter Pin
20	00755632	1	Shim
21	00755633	1	Plug, Oil Level Check
22	00755634	1	Seal Cap, Rear
23	00755635	4	Bolt
24	00758654	1	Plug, Vent / Oil Fill
25	00755637	1	Cover, Top
27	02959391	6	Bolt
28	00037200	6	Locknut
29	00755624	1	Nut, Blade Carrier Retaining
30	00755623	1	Washer, Blade Carrier
31	163016	1	Cotterpin, Blade Carrier

NOTE: This Gearbox has a Square Bolt on Top Cover & Input Gear is mounted in the front as shown in drawing

Gearbox

P/N 00756622

Assembly Instructions

Gearbox Output Shaft Installation:
Installation Part Numbers are for Gearbox #00756622 (1000 RPM)

1. **Install Output Shaft** (Blade Shaft), Bearings, Gear in Main Housing (#00755613)
2. Install Upper Bearing Cup (#00755628 Cup & Cone) into Main Housing (#00755613) from the top, Install Lower Bearing Cup (#00755628) into Main housing from the bottom.
3. Install the Lower Bearing Cone (#00755628 Cup & Cone) down over Output Shaft. Insert Output Shaft with Bearing Cone on it up through Main Housing from the bottom. Put Upper Bearing Cone (#00755628 Cup & Cone) over Output Shaft and slide down till it bottoms out in upper Bearing Cup.
4. Install Shims (#00755622) down over top of Output Shaft, The number of shims required will vary, try to use the same amount as were removed. Install Output Gear (#00756899) over Output Shaft, Make sure it is seated against Shim. Insert Shim (#00755638 washer) down against gear, Screw Slotted Bearing Adjusting Nut (#00756943) onto top of Output Shaft.
5. Tighten Bearing Adjusting Nut above Gear till Bearings have 14" to 16" pounds of rolling Torque then secure Bearing Adjusting Nut with Cotter Pin.
6. DO NOT Install Output Seal (#00755627) now, wait till Input Shaft has been installed, When you do install it Coat ID of Seal with light coat of grease. Install Seal Protector (#00755626), this drives into lower Main Housing, This Seal Protector Should always be replaced with new one after being removed. Re-Check Bearing Pre-load. Output Shaft Should have NO end play and Bearing MUST be set at a rolling Torque. (See 5.)
7. **Install Input Shaft**, Bearings and Gear into Main Housing (#00755613)
8. Install External Clip (#00755620) on Input Shaft (#00755617) next to where Gear goes. Install External Clip (#00755632) on Input Shaft next to rear Bearing area. Drop Input Gear (#00756900) into Gearbox Main Housing from the top. Holding Gear in place insert Input Shaft into Main Housing from the rear through rear Bearing opening on center and left wing Gearbox, from the front on Right wing Gearbox. Slide shaft guiding it through input Gear. slide Shaft in till External Clip is against Gear.
9. Install Rear Input Bearing Cone (#00755615 Cup & Cone) into Rear of Main Housing till it is against External Clip on Shaft. Install Bearing Cup (#00755615 Cup & Cone) into rear of main housing, Install Shims (#00755619) in against Bearing Cup try to use the same amount of shims as were removed. Install Internal Clip (#00755618) into Main Housing against Shims. DO NOT install any Seals at this time. Install Front Bearing Cone (#00755615 Cup & Cone) onto Input Shaft from the front till they are against Input Gear. Install Shims against Bearing Cup, Install Internal Clip (#00755618) into front of Main Housing against Shims. DO NOT install any Seals at this time.
10. Check Bearing Pre-Load (should be 14" to 16" pounds of rolling Torque) and Gear Back Lash between Blade Shaft Gear and Input Gear (should have .017" to .019" back Lash) If it is not correct, Add or remove shims from Input Shaft Bearings will change Bearing Pre-load, Move Shim from one side of input Bearing to other to Get Correct Back Lash, It may be required to add or remove shims from Blade Shaft output Gear to raise or lower it to get correct Back lash. Once all is correct Install Input Seal (#00755616) and Rear Seal Cap (#00755634) then recheck Gear and Bearing settings. Now is the time to install Output seal and lower seal protector, (see step 6).

Gearbox

P/N 00755598

Assembly Instructions

11. When this has been Done fill Gearbox with Oil, Before deciding Gearbox is full wait long enough for Oil to run down between Output Shaft Bearing, Then refill with Oil, install Top Cover (using Sealer for Gasket), Oil Plugs and check for leaks, After running Mower 1/2 to 1 hour check Oil Level and recheck for leaks.

NOTE: The Following Gearboxes will assemble the same as the above with very minor differences, some componet numbers and the location of the Input gear.

Gear Box #	RPM	Input Gear
00755598.....	540 rpm.....	Front
00755566.....	540 rpm.....	Rear
00756622.....	1000 rpm.....	Front
00756624.....	1000 rpm.....	Rear
00756739.....	1000 rpm.....	Front
00756741.....	1000 rpm.....	Rear
00756744.....	1000 rpm.....	Front
00760453.....	540 rpm.....	Front

Gearbox

P/N 00756624

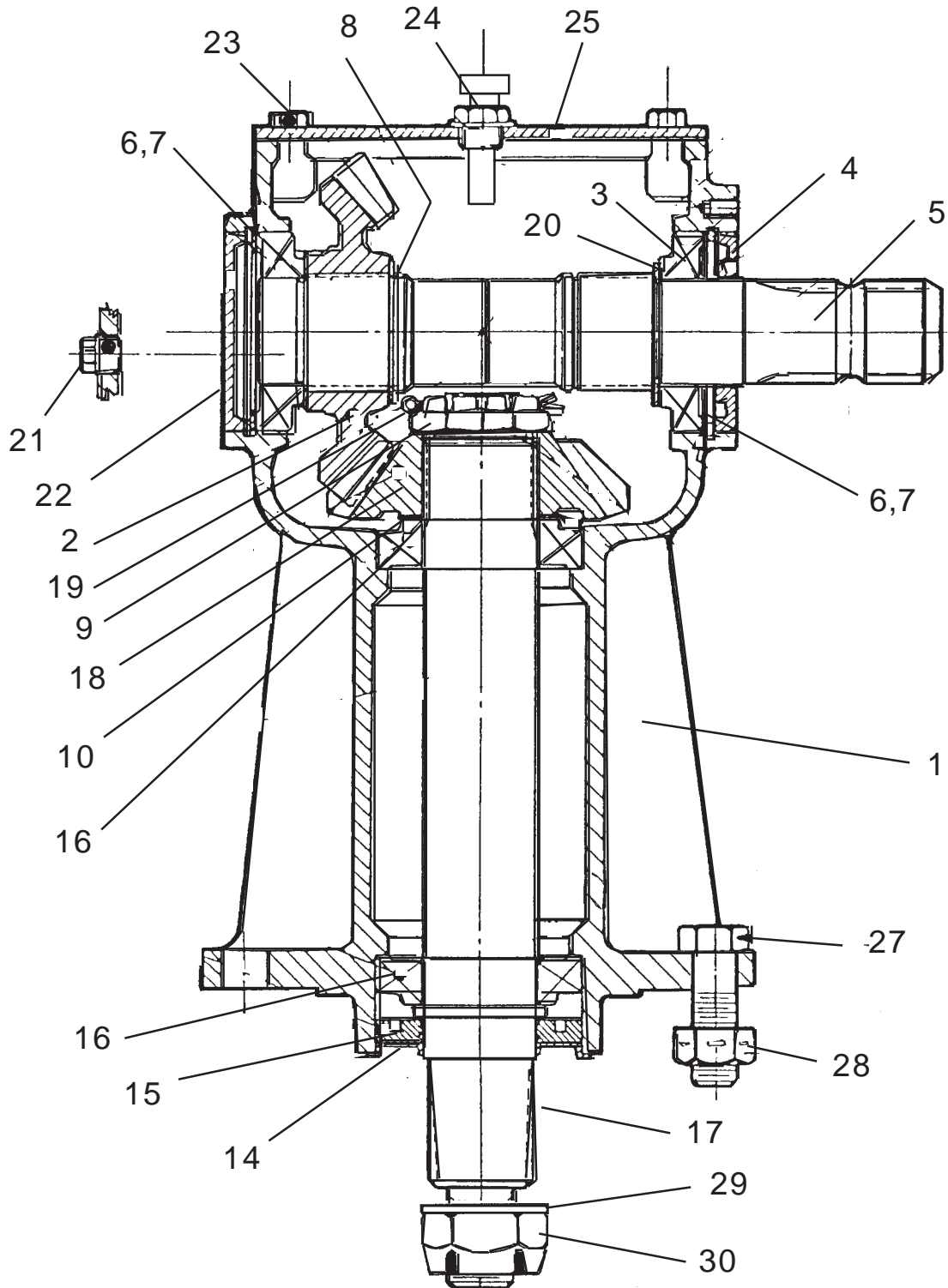

CW IN - CW OUT

Gearbox

P/N 00756624

P/N 00756624 (1000 RPM) CW IN - CW OUT

Item	Part No.	Qty.	Description
1	00755613	1	Casing
2	00756900	1	Gear (20 Teeth-1000RPM)
3	00755615	2	Bearing
4	00753238	1	Oil Seal
5	00755617	1	Shaft
6	00755618	2	Internal Circlip
7	00755619	2	Shim
8	00755620	1	External Circlip
9	00756943	1	Nut
10	00755622	1	Shim
14	00755626	1	Protective Shield
15	00755627	1	Oil Seal
16	00755628	2	Bearing
17	00756945	1	Shaft
18	00756899	1	Gear (24 Teeth-100RPM)
19	00756946	1	Cotter Pin
20	00755632	1	Shim
21	00755633	1	Plug
22	00755634	1	Cap
23	00755635	4	Hex Bolt
24	00758654	1	Vent Plug
25	00755637	1	Cover
27	02959391	6	Bolt
28	00037200	6	Locknut
29	00755623	1	Washer
30	00755624	1	Nut, Castle
31	163016	1	Cotterpin, Blade Carrier

NOTE: This Gearbox has a Square Bolt on Top Cover & Input Gear is mounted in the Back as shown in drawing

Gearbox

P/N 00756624

Assembly Instructions

Gearbox Output Shaft Installation:

Installation Part Numbers are for Gearbox #00756624 (1000 RPM)

- 1. Install Output Shaft** (Blade Shaft), Bearings, Gear in Main Housing (#00755613)
- Install Upper Bearing Cup (#00755628 Cup & Cone) into Main Housing (#00755613) from the top, Install Lower Bearing Cup (#00755628) into Main housing from the bottom.
- Install the Lower Bearing Cone (#00755628 Cup & Cone) down over Output Shaft. Insert Output Shaft with Bearing Cone on it up through Main Housing from the bottom. Put Upper Bearing Cone (#00755628 Cup & Cone) over Output Shaft and slide down till it bottoms out in upper Bearing Cup.
- Install Shims (#00755622) down over top of Output Shaft, The number of shims required will vary, try to use the same amount as were removed. Install Output Gear (#00756899) over Output Shaft, Make sure it is seated against Shim. Insert Shim (#00755638 washer) down against gear, Screw Slotted Bearing Adjusting Nut (#00756943) onto top of Output Shaft.
- Tighten Bearing Adjusting Nut above Gear till Bearings have 14" to 16" pounds of rolling Torque then secure Bearing Adjusting Nut with Cotter Pin.
- DO NOT Install Output Seal (#00755627) now, wait till Input Shaft has been installed, When you do install it Coat ID of Seal with light coat of grease. Install Seal Protector (#00755626), this drives into lower Main Housing, This Seal Protector Should always be replaced with new one after being removed. Re-Check Bearing Pre-load. Output Shaft Should have NO end play and Bearing MUST be set at a rolling Torque. (See 5.)
- Install Input Shaft**, Bearings and Gear into Main Housing (#00755613)
- Install External Clip (#00755620) on Input Shaft (#00755617) next to where Gear goes. Install External Clip (#00755632) on Input Shaft next to rear Bearing area. Drop Input Gear (#00756900) into Gearbox Main Housing from the top. Holding Gear in place insert Input Shaft into Main Housing from the rear through rear Bearing opening on center and left wing Gearbox, from the front on Right wing Gearbox. Slide shaft guiding it through input Gear. slide Shaft in till External Clip is against Gear.
- Install Rear Input Bearing Cone (#00755615 Cup & Cone) into Rear of Main Housing till it is against External Clip on Shaft. Install Bearing Cup (#00755615 Cup & Cone) into rear of main housing, Install Shims (#00755619) in against Bearing Cup try to use the same amount of shims as were removed. Install Internal Clip (#00755618) into Main Housing against Shims. DO NOT install any Seals at this time. Install Front Bearing Cone (#00755615 Cup & Cone) onto Input Shaft from the front till they are against Input Gear. Install Shims against Bearing Cup, Install Internal Clip (#00755618) into front of Main Housing against Shims. DO NOT install any Seals at this time.
- Check Bearing Pre-Load (should be 14" to 16" pounds of rolling Torque) and Gear Back Lash between Blade Shaft Gear and Input Gear (should have .017" to .019" back Lash) If it is not correct, Add or remove shims from Input Shaft Bearings will change Bearing Pre-load, Move Shim from one side of input Bearing to other to Get Correct Back Lash, It may be required to add or remove shims from Blade Shaft output Gear to raise or lower it to get correct Back lash. Once all is correct Install Input Seal (#00755616) and Rear Seal Cap (#00755634) then recheck Gear and Bearing settings. Now is the time to install Output seal and lower seal protector, (see step 6).

Gearbox

P/N 00756624

Assembly Instructions

11. When this has been Done fill Gearbox with Oil, Before deciding Gearbox is full wait long enough for Oil to run down between Output Shaft Bearing, Then refill with Oil, install Top Cover (using Sealer for Gasket), Oil Plugs and check for leaks, After running Mower 1/2 to 1 hour check Oil Level and recheck for leaks.

NOTE: The Following Gearboxes will assemble the same as the above with very minor differences, some componet numbers and the location of the Input gear.

Gear Box #	RPM	Input Gear
00755598.....	540 rpm.....	Front
00755566.....	540 rpm.....	Rear
00756622.....	1000 rpm.....	Front
00756624.....	1000 rpm.....	Rear
00756739.....	1000 rpm.....	Front
00756741.....	1000 rpm.....	Rear
00756744.....	1000 rpm.....	Front
00760453.....	540 rpm.....	Front

Gearbox P/N 00756739

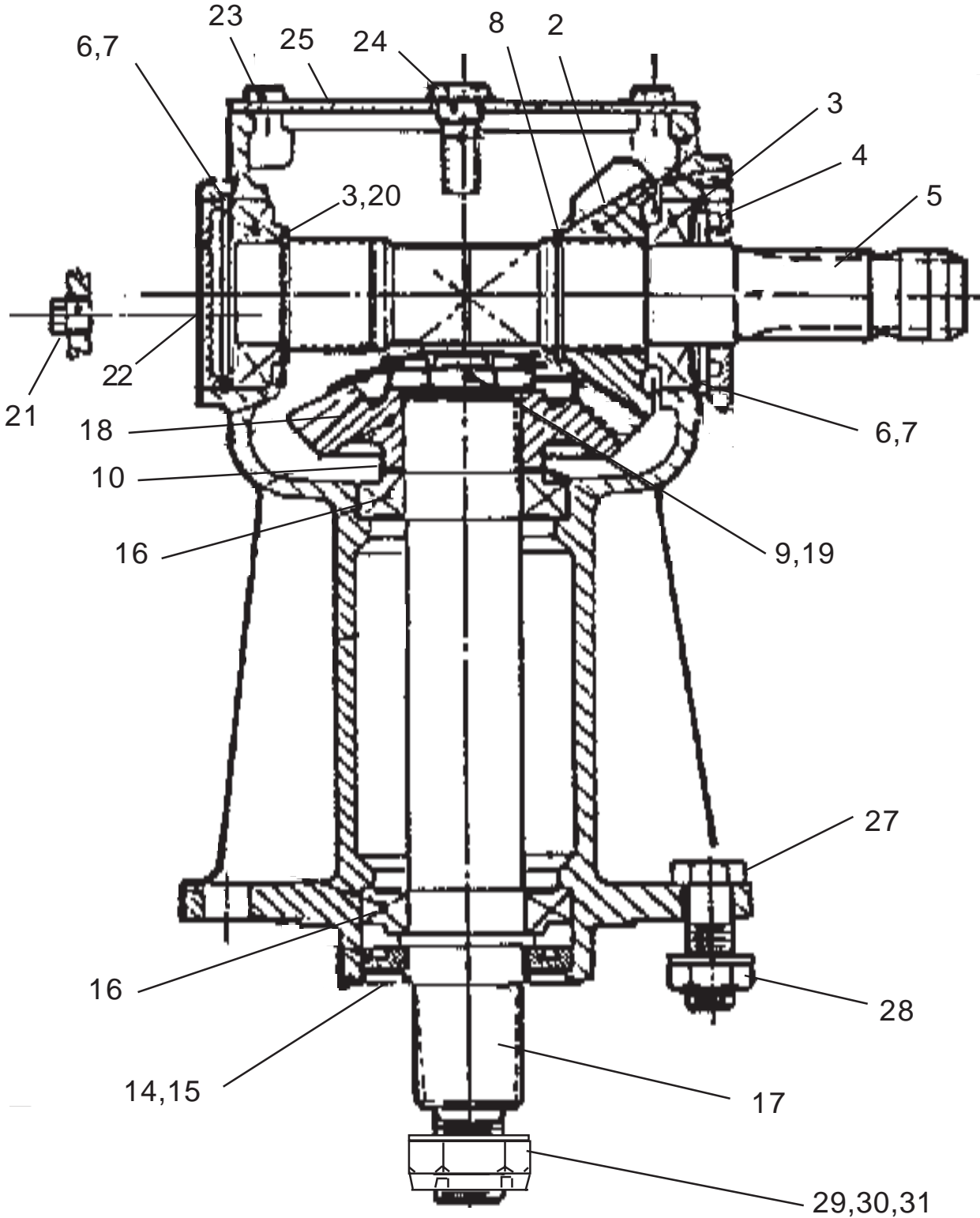

Note: rn CCW

Gearbox

P/N 00756739

P/N 00756739 (540 RPM) CW IN - CCW OUT

Item	Part No.	Qty	Description
	00756739	--	Gearbox Asy, (540 RPM)
1	00755613	1	Gearbox Housing, Main
2	00756899	1	Gear, 540 RPM Input (24 Tooth)
3	00755615	2	Bearing
4	00753238	1	Seal
5	00755617	1	Shaft, Input
6	00755618	2	Circlip, Internal
7	00755619	2	Shim
8	00755620	1	Circlip, External
9	00756943	1	Nut, Slotted
10	00755622	1	Shim
14	00755626	1	Shield, Protective
15	00755627	1	Seal
16	00755628	2	Bearing
17	00756945	1	Shaft, Output
18	00756900	1	Gear, 540 RPM Output (20 Tooth)
19	00756946	1	Cotter Pin
20	00755632	1	Shim
21	00755633	1	Plug, Oil Level Check
22	00755634	1	Seal Cap, Rear
23	00755635	4	Bolt
24	00758654	1	Plug, Vent / Oil Fill
25	00755637	1	Cover, Top
27	02959391	6	Bolt
28	00037200	6	Locknut
29	00755624	1	Nut, Blade Carrier Retaining
30	00755623	1	Washer, Blade Carrier
31	163016	1	Cotterpin, Blade Carrier

NOTE: This Gearbox has a Square Bolt on Top Cover & Input Gear is mounted in the front as shown in drawing

Gearbox

P/N 00756739

Assembly Instructions

Gearbox Output Shaft Installation:

Installation Part Numbers are for Gearbox #00756739 (1000 RPM)

1. **Install Output Shaft** (Blade Shaft), Bearings, Gear in Main Housing (#00755613)
2. Install Upper Bearing Cup (#00755628 Cup & Cone) into Main Housing (#00755613) from the top, Install Lower Bearing Cup (#00755628) into Main housing from the bottom.
3. Install the Lower Bearing Cone (#00755628 Cup & Cone) down over Output Shaft. Insert Output Shaft with Bearing Cone on it up through Main Housing from the bottom. Put Upper Bearing Cone (#00755628 Cup & Cone) over Output Shaft and slide down till it bottoms out in upper Bearing Cup.
4. Install Shims (#00755622) down over top of Output Shaft, The number of shims required will vary, try to use the same amount as were removed. Install Output Gear (#00756900) over Output Shaft, Make sure it is seated against Shim. Insert Shim (#00755638 washer) down against gear, Screw Slotted Bearing Adjusting Nut (#00756943) onto top of Output Shaft.
5. Tighten Bearing Adjusting Nut above Gear till Bearings have 14" to 16" pounds of rolling Torque then secure Bearing Adjusting Nut with Cotter Pin.
6. DO NOT Install Output Seal (#00755627) now, wait till Input Shaft has been installed, When you do install it Coat ID of Seal with light coat of grease. Install Seal Protector (#00755626), this drives into lower Main Housing, This Seal Protector Should always be replaced with new one after being removed. Re-Check Bearing Pre-load. Output Shaft Should have NO end play and Bearing MUST be set at a rolling Torque. (See 5.)
7. **Install Input Shaft**, Bearings and Gear into Main Housing (#00755613)
8. Install External Clip (#00755620) on Input Shaft (#00755617) next to where Gear goes. Install External Clip (#00755632) on Input Shaft next to rear Bearing area. Drop Input Gear (#00756899) into Gearbox Main Housing from the top. Holding Gear in place insert Input Shaft into Main Housing from the rear through rear Bearing opening on center and left wing Gearbox, from the front on Right wing Gearbox. Slide shaft guiding it through input Gear. slide Shaft in till External Clip is against Gear.
9. Install Rear Input Bearing Cone (#00755615 Cup & Cone) into Rear of Main Housing till it is against External Clip on Shaft. Install Bearing Cup (#00755615 Cup & Cone) into rear of main housing, Install Shims (#00755619) in against Bearing Cup try to use the same amount of shims as were removed. Install Internal Clip (#00755618) into Main Housing against Shims. DO NOT install any Seals at this time. Install Front Bearing Cone (#00755615 Cup & Cone) onto Input Shaft from the front till they are against Input Gear. Install Shims against Bearing Cup, Install Internal Clip (#00755618) into front of Main Housing against Shims. DO NOT install any Seals at this time.
10. Check Bearing Pre-Load (should be 14" to 16" pounds of rolling Torque) and Gear Back Lash between Blade Shaft Gear and Input Gear (should have .017" to .019" back Lash) If it is not correct, Add or remove shims from Input Shaft Bearings will change Bearing Pre-load, Move Shim from one side of input Bearing to other to Get Correct Back Lash, It may be required to add or remove shims from Blade Shaft output Gear to raise or lower it to get correct Back lash. Once all is correct Install Input Seal (#00755616) and Rear Seal Cap (#00755634) then recheck Gear and Bearing settings. Now is the time to install Output seal and lower seal protector, (see step 6).

Gearbox

P/N 00756739

Assembly Instructions

11. When this has been Done fill Gearbox with Oil, Before deciding Gearbox is full wait long enough for Oil to run down between Output Shaft Bearing, Then refill with Oil, install Top Cover (using Sealer for Gasket), Oil Plugs and check for leaks, After running Mower 1/2 to 1 hour check Oil Level and recheck for leaks.

NOTE: The Following Gearboxes will assemble the same as the above with very minor differences, some componet numbers and the location of the Input gear.

Gear Box #	RPM	Input Gear
00755598.....	540 rpm.....	Front
00755566.....	540 rpm.....	Rear
00756622.....	1000 rpm.....	Front
00756624.....	1000 rpm.....	Rear
00756739.....	1000 rpm.....	Front
00756741.....	1000 rpm.....	Rear
00756744.....	1000 rpm.....	Front
00760453.....	540 rpm.....	Front

Gearbox P/N 00756741

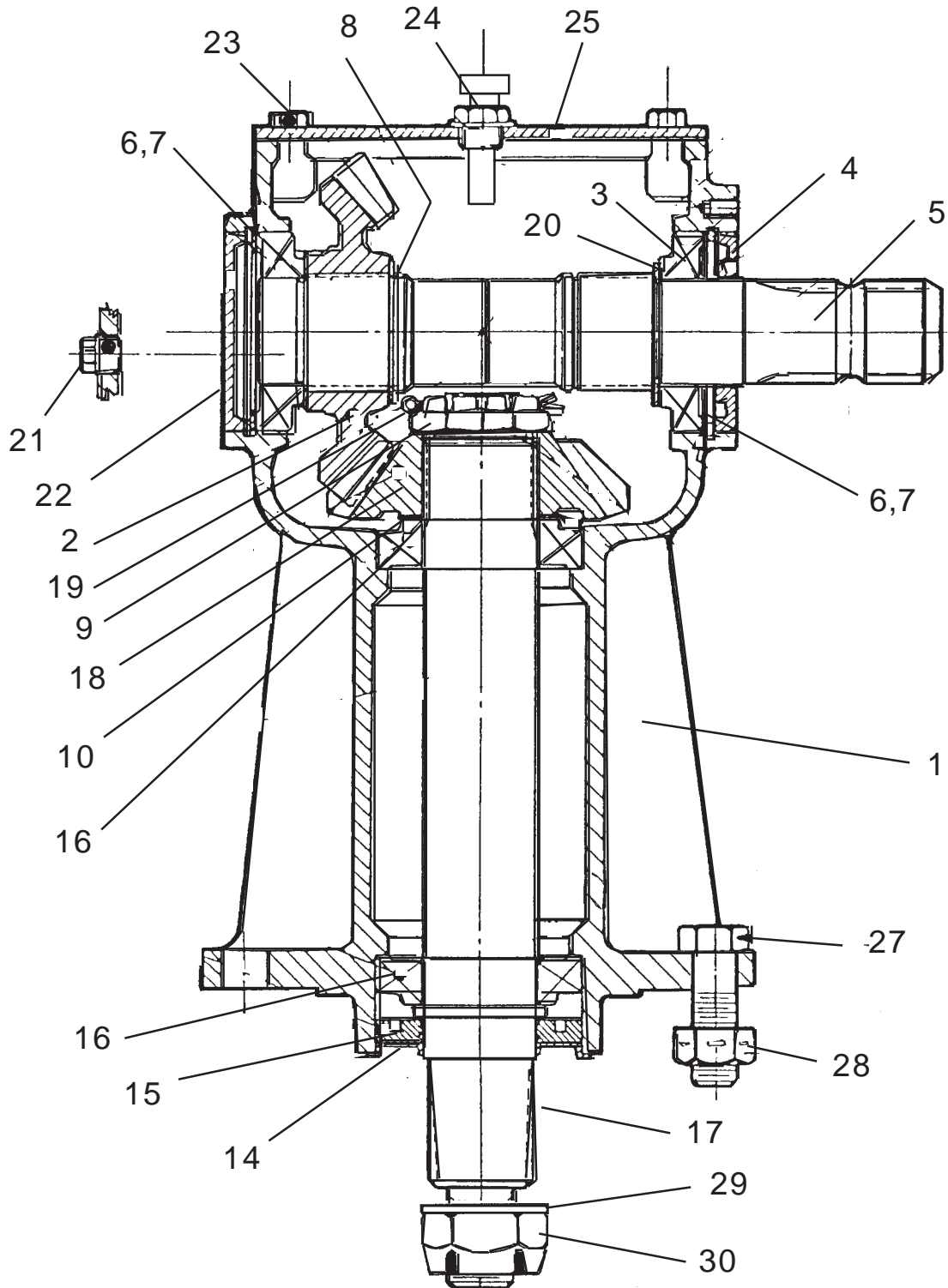

CW IN - CW OUT

Gearbox

P/N 00756741

P/N 00756741 (540 RPM) CW IN - CW OUT

Item	Part No.	Qty.	Description
1	00755613	1	Casing
2	00756899	1	Gear (24 Teeth-540RPM)
3	00755615	2	Bearing
4	00753238	1	Oil Seal
5	00755617	1	Shaft
6	00755618	2	Internal Circlip
7	00755619	2	Shim
8	00755620	1	External Circlip
9	00756943	1	Nut
10	00755622	1	Shim
14	00755626	1	Protective Shield
15	00755627	1	Oil Seal
16	00755628	2	Bearing
17	00756945	1	Shaft
18	00756900	1	Gear (20 Teeth-540 RPM)
19	00756946	1	Cotter Pin
20	00755632	1	Shim
21	00755633	1	Plug
22	00755634	1	Cap
23	00755635	4	Hex Bolt
24	00758654	1	Vent Plug
25	00755637	1	Cover
27	02959391	6	Bolt
28	00037200	6	Locknut
29	00755623	1	Washer
30	00755624	1	Nut, Castle
31	163016	1	Cotterpin, Blade Carrier

NOTE: This Gearbox has a Square Bolt on Top Cover & Input Gear is mounted in the Back as shown in drawing

Gearbox

P/N 00756741

Assembly Instructions

Gearbox Output Shaft Installation:

Installation Part Numbers are for Gearbox #00756741 (1000 RPM)

- 1. Install Output Shaft** (Blade Shaft), Bearings, Gear in Main Housing (#00755613)
- Install Upper Bearing Cup (#00755628 Cup & Cone) into Main Housing (#00755613) from the top, Install Lower Bearing Cup (#00755628) into Main housing from the bottom.
- Install the Lower Bearing Cone (#00755628 Cup & Cone) down over Output Shaft. Insert Output Shaft with Bearing Cone on it up through Main Housing from the bottom. Put Upper Bearing Cone (#00755628 Cup & Cone) over Output Shaft and slide down till it bottoms out in upper Bearing Cup.
- Install Shims (#00755622) down over top of Output Shaft, The number of shims required will vary, try to use the same amount as were removed. Install Output Gear (#00756900) over Output Shaft, Make sure it is seated against Shim. Insert Shim (#00755638 washer) down against gear, Screw Slotted Bearing Adjusting Nut (#00756943) onto top of Output Shaft.
- Tighten Bearing Adjusting Nut above Gear till Bearings have 14" to 16" pounds of rolling Torque then secure Bearing Adjusting Nut with Cotter Pin.
- DO NOT Install Output Seal (#00755627) now, wait till Input Shaft has been installed, When you do install it Coat ID of Seal with light coat of grease. Install Seal Protector (#00755626), this drives into lower Main Housing, This Seal Protector Should always be replaced with new one after being removed. Re-Check Bearing Pre-load. Output Shaft Should have NO end play and Bearing MUST be set at a rolling Torque. (See 5.)
- Install Input Shaft**, Bearings and Gear into Main Housing (#00755613)
- Install External Clip (#00755620) on Input Shaft (#00755617) next to where Gear goes. Install External Clip (#00755632) on Input Shaft next to rear Bearing area. Drop Input Gear (#00756899) into Gearbox Main Housing from the top. Holding Gear in place insert Input Shaft into Main Housing from the rear through rear Bearing opening on center and left wing Gearbox, from the front on Right wing Gearbox. Slide shaft guiding it through input Gear. slide Shaft in till External Clip is against Gear.
- Install Rear Input Bearing Cone (#00755615 Cup & Cone) into Rear of Main Housing till it is against External Clip on Shaft. Install Bearing Cup (#00755615 Cup & Cone) into rear of main housing, Install Shims (#00755619) in against Bearing Cup try to use the same amount of shims as were removed. Install Internal Clip (#00755618) into Main Housing against Shims. DO NOT install any Seals at this time. Install Front Bearing Cone (#00755615 Cup & Cone) onto Input Shaft from the front till they are against Input Gear. Install Shims against Bearing Cup, Install Internal Clip (#00755618) into front of Main Housing against Shims. DO NOT install any Seals at this time.
- Check Bearing Pre-Load (should be 14" to 16" pounds of rolling Torque) and Gear Back Lash between Blade Shaft Gear and Input Gear (should have .017" to .019" back Lash) If it is not correct, Add or remove shims from Input Shaft Bearings will change Bearing Pre-load, Move Shim from one side of input Bearing to other to Get Correct Back Lash, It may be required to add or remove shims from Blade Shaft output Gear to raise or lower it to get correct Back lash. Once all is correct Install Input Seal (#00755616) and Rear Seal Cap (#00755634) then recheck Gear and Bearing settings. Now is the time to install Output seal and lower seal protector, (see step 6).

Gearbox

P/N 00756741

Assembly Instructions

11. When this has been Done fill Gearbox with Oil, Before deciding Gearbox is full wait long enough for Oil to run down between Output Shaft Bearing, Then refill with Oil, install Top Cover (using Sealer for Gasket), Oil Plugs and check for leaks, After running Mower 1/2 to 1 hour check Oil Level and recheck for leaks.

NOTE: The Following Gearboxes will assemble the same as the above with very minor differences, some componet numbers and the location of the Input gear.

Gear Box #	RPM	Input Gear
00755598.....	540 rpm.....	Front
00755566.....	540 rpm.....	Rear
00756622.....	1000 rpm.....	Front
00756624.....	1000 rpm.....	Rear
00756739.....	1000 rpm.....	Front
00756741.....	1000 rpm.....	Rear
00756744.....	1000 rpm.....	Front
00760453.....	540 rpm.....	Front

Gearbox

P/N 00756744

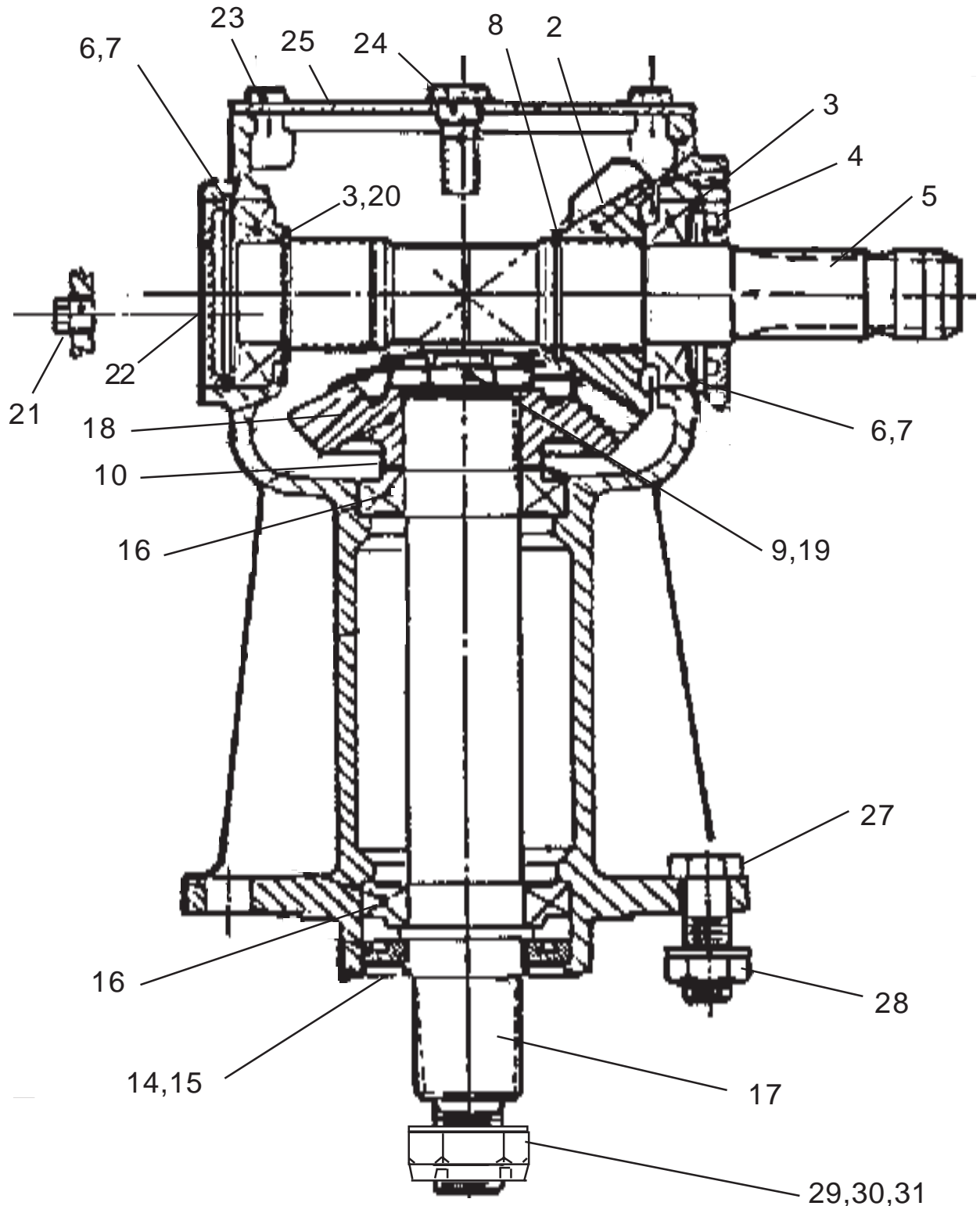

Note: Blades Turn CCW

Gearbox

P/N 00756744

P/N 00756744 CW IN - CCW OUT

Item	Part No.	Qty	Description
	00756744	--	Gearbox Asy.
1	00755613	1	Gearbox Housing, Main
2	00756942	1	Gear, Input 15 Tooth (1000 RPM)
3	00755615	2	Bearing
4	00753238	1	Seal
5	00755617	1	Shaft, Input
6	00755618	2	Circlip, Internal
7	00755619	2	Shim
8	00755620	1	Circlip, External
9	00756943	1	Nut, Slotted
10	00755622	1	Shim
14	00755626	1	Shield, Protective
15	00755627	1	Seal
16	00755628	2	Bearing
17	00756945	1	Shaft, Output
18	00756944	1	Gear, Output 24 Tooth (1000 RPM)
19	00756946	1	Cotter Pin
20	00755632	1	Shim
21	00755633	1	Plug, Oil Level Check
22	00755634	1	Seal Cap, Rear
23	00755635	4	Bolt
24	00758654	1	Plug, Vent / Oil Fill
25	00755637	1	Cover, Top
27	02959391	6	Bolt
28	00037200	6	Locknut
29	00755624	1	Nut, Blade Carrier Retaining
30	00755623	1	Washer, Blade Carrier
31	163016	1	Cotterpin, Blade Carrier

NOTE: This Gearbox has a Square Bolt on Top Cover & Input Gear is mounted in the front as shown in drawing

Gearbox

P/N 00756744

Assembly Instructions

Gearbox Assembly

Installation Part Numbers are for Gearbox #00756744 (1000 RPM)

- 1. Install Output Shaft** (Blade Shaft), Bearings, Gear in Main Housing (#00755613)
- 2.** Install Upper Bearing Cup (#00755628 Cup & Cone) into Main Housing (#00755613) from the top, Install Lower Bearing Cup (#00755628) into Main housing from the bottom.
- 3.** Install the Lower Bearing Cone (#00755628 Cup & Cone) down over Output Shaft. Insert Output Shaft with Bearing Cone on it up through Main Housing from the bottom. Put Upper Bearing Cone (#00755628 Cup & Cone) over Out Put Shaft and slide down till it bottoms out in upper Bearing Cup.
- 4.** Install Shims (#00755622) down over top of Output Shaft, The number of shims required will vary, try to use the same amount as were removed. Install Output Gear (#00756944) over Output Shaft, Make sure it is seated against Shim. Insert Shim (#00755638 washer) down against gear, Screw Slotted Bearing Adjusting Nut (#00756943) onto top of Out put Shaft.
- 5.** Tighten Bearing Adjusting Nut above Gear till Bearings have 14" to 16" pounds of rolling Torque then secure Bearing Adjusting Nut with Cotter Pin.
- 6.** DO NOT Install Output Seal (#00755627) now, wait till Input Shaft has been installed, When you do install it Coat ID of Seal with light coat of grease. Install Seal Protector (#00755626), this drives into lower Main Housing, This Seal Protector Should always be replaced with new one after being removed. Re-Check Bearing Pre-load. Output Shaft Should have NO end play and Bearing MUST be set at a rolling Torque. (See 5.)
- 7. Install Input Shaft**, Bearings and Gear into Main Housing (#00755613)
- 8.** Install External Clip (#00755620) on Input Shaft (#00755617) next to where Gear goes. Install External Clip (#00755632) on Input Shaft next to rear Bearing area. Drop Input Gear (#00756942) into Gearbox Main Housing from the top. Holding Gear inplace insert Input Shaft into Main Housing from the rear through rear Bearing opening on center and left wing Gearbox, from the front on Right wing Gearbox. Slide shaft guiding it through input Gear. slide Shaft in till External Clip is against Gear.
- 9.** Install Rear Input Bearing Cone (#00755615 Cup & Cone) into Rear of Main Housing till it is against External Clip on Shaft. Install Bearing Cup (#00755615 Cup & Cone) into rear of main housing, Install Shims (#00755619) in against Bearing Cup try to use the same amount of shims as were removed. Install Internal Clip (#00755618) into Main Housing against Shims. DO NOT install any Seals at this time. Install Front Bearing Cone (#00755615 Cup & Cone) onto Input Shaft from the front till they are against Input Gear. Install Shims against Bearing Cup, Install Internal Clip (#00755618) into front of Main Housing against Shims. DO NOT install any Seals at this time.
- 10.** Check Bearing Pre-Load (should be 14" to 16" pounds of rolling Torque) and Gear Back Lash between Blade Shaft Gear and Input Gear (should have .017" to .019" back Lash) If it is not correct, Add or remove shims from Input Shaft Bearings will change Bearing Pre-load, Move Shim from one side of input Bearing to other to Get Correct Back Lash, It may be required to add or remove shims from Blade Shaft output Gear to raise or lower it to get correct Back lash. Once all is correct Install Input Seal (#00755616) and Rear Seal Cap (#00755634) then recheck Gear and Bearing settings. Now is the time to install Output seal and lower seal protector, (see step 6).

Gearbox

P/N 00756744

Assembly Instructions

11. When this has been Done fill Gearbox with Oil, Before deciding Gearbox is full wait long enough for Oil to run down between Output Shaft Bearing, Then refill with Oil, install Top Cover (using Sealer for Gasket), Oil Plugs and check for leaks, After running Mower 1/2 to 1 hour check Oil Level and recheck for leaks.

NOTE: The Following Gearboxes will assemble the same as the above with very minor differences, some componet numbers and the location of the Input gear.

Gear Box #	RPM	Input Gear
00755598.....	540 rpm.....	Front
00755566.....	540 rpm.....	Rear
00756622.....	1000 rpm.....	Front
00756624.....	1000 rpm.....	Rear
00756739.....	1000 rpm.....	Front
00756741.....	1000 rpm.....	Rear
00756744.....	1000 rpm.....	Front
00760453.....	540 rpm.....	Front

GEARBOX

P/N 00757825

1-3/4" Seal ID with Metal Seal Adapter (Item # 10)

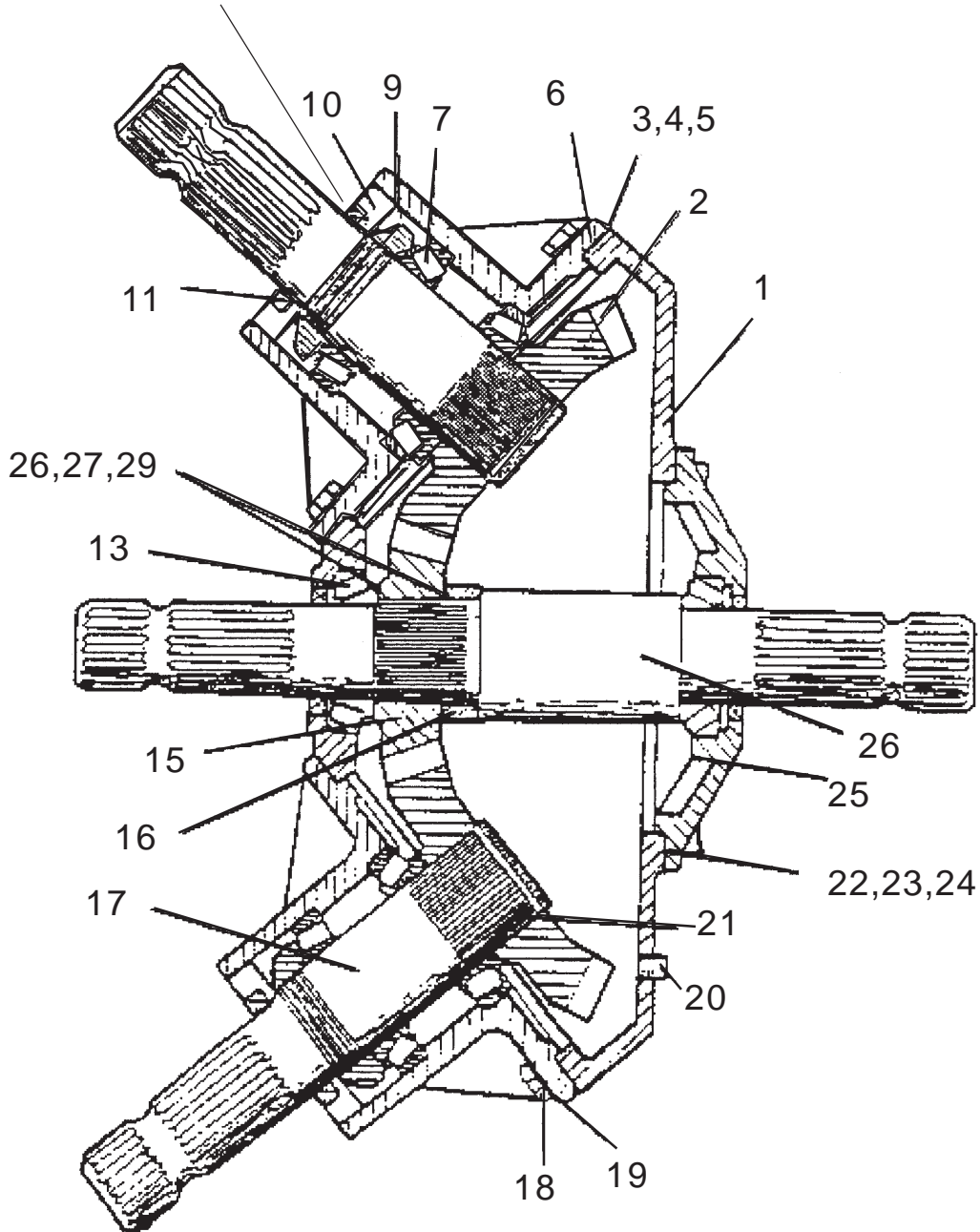

NOTE: To help ID this Gearbox look at Seal for Output Shaft going to the Wing Drivelines. These seals have a 1-3/4" ID and use a Metal Seal adapter (item # 10) at OD of Seals, **These Seal Adapters (item # 10) are only used on this Gearbox.**

GEARBOX

P/N 00757825

Item	Part No.	Qty	Description
	00757825	-	Gearbox Asy (540 RPM)
1	00758644	1	Housing
2	00758645	2	Gear 20 Tooth
3	00758646	A/R	Shim (.004)
4	00758647	A/R	Shim (.010)
5	00758648	A/R	Shim (.020)
6	00758649	2	Horizontal Hub Cap
7	00758650	4	Bearing
9	00758651	2	Adjusting Nut
10	00758652	2	Seal Adapter
11	00758653	4	Seal
12	00758654	1	Vented Pipe Plug
13	00758655	2	Bearing
15	00758656	1	Gear 23 Tooth
16	00758657	1	Input Shaft Spacer
17	00758658	2	Horizontal Output Shaft
18	00758659	18	Cap Screw
19	00755954	18	Lockwasher
20	00565000	1	Pipe Plug
21	00758660	2	Retaining Ring
22	00758646	A/R	Shim (.004)
23	00758647	A/R	Shim (.010)
24	00758648	A/R	Shim (.020)
25	00758664	1	Input Cap
26	00758665	1	Input Shaft
27	00758666	A/R	Shim (.004)
28	00758667	A/R	Shim (.010)
29	00758668	A/R	Shim (.020)

NOTE: To help ID this Gearbox look at Seal for Output Shaft going to the Wing Drivelines. These seals have a 1-3/4" ID and use a Metal Seal adapter (item # 10) at OD of Seals, **These Seal Adapters (item # 10) are only used on this Gearbox.**

GEARBOX

P/N 00757825

Assembly Instructions

Installation of Parts For Gearbox # 00757825 (540 rpm)

- 1. Install Input Shaft** (Center Shaft), Bearings, Gear in Main Housing (#00758644) install Input shaft before Output Shafts to Wings
- 2.** Install Bearing Cup (#00758655 Cup & Cone) in Main Housing and Bearing Cup (#00758655 Cup & Cone) in front Bearing Carrier Cap (#00758664), Drive Cups in till they bottom out, Check this before continuing. Then Lay Bearing Carrier Cap aside for now.
- 3.** Install Gear Spacer (#00758657) onto Input Shaft, Slide Gear (#00758656 (23 tooth) 540 rpm or #00758670 (20 tooth) 1000 rpm)) onto Input Shaft making sure gear is against Gear Spacer, If Gear is put on backward the assemblies for Wing Output won't fit. Next install Inner Bearing Cone (#00758655 Cup & Cone) and outer Bearing Cone (#00758655 Cup & Cone) on to Shaft making sure inner bearing is bottomed out against gear and outer Bearing Cone is against shoulder on Input Shaft.
- 4.** Install Seal (#00758653) into Bearing Carrier Cap and Seal (#00758653) into rear of Main Housing. Coat ID of Seals with light coat of Grease, using Shims (DO NOT put Gasket Sealer on Shims at this time) Tighten down Bearing Carrier Cap and check Bearing Pre-Load, It should be 14 to 16 inch pounds of rolling torque, Shaft should not have any end play in or out. If less Pre-Load is needed remove Shims if more is needed add shims. If Bearing preload is right, remove Bearing Carrier Cap and coat shims with Sealer and re-install, Tighten Bolts and Recheck Bearing Preload.
- 5.** When this has been Done go on to Step 2, Installing Wing Output Shaft Assembly with Gear. The Gear Backlash will be set at .017" to .019"
- 6. Install Output Shaft Asy**, Bearings, Gear (Output) in Horizontal Hub Housing (#00758649) Always install Center Input Shaft in Main Housing first, see step 1.
- 7.** Install Outer Bearing Cup (#00758650 Cup & Cone) and Inner Bearing Cup (#00758650 Cup & Cone) into Horizontal Hub Housing (#00758649), (inner cup near gear and one outer cup near seal), They are the same and can be installed inner or outer Cup, Install cups in Housing till they bottom out against shoulders in Housing.
- 8.** Install Inner Bearing Cone (#00758650 Cup & Cone) onto Output Shaft (# 00757895), Make sure Bearing is seated down against on shaft far enough that Gear can be installed. Install Gear (#00758645 (20 tooth) 540 rpm or #00758669 (26 tooth) 1000 rpm)
- 9.** Install Snap Ring (#00758660) onto Output Shaft (#00758658) this holds gear on Shaft. Insert Shaft with Gear and Bearing on into Horizontal Housing. Install Outer Bearing Cone (#00758650 Cup & Cone) over Output Shaft and into Housing till it seats against Outer Bearing Cup. Screw Bearing Adjusting Nut onto Output Shaft till it touches Bearing Cone. Continue to tighten Bearing Adjusting Nut till Bearings have 14" to 16" pounds of rolling torque. Tap Shaft with a Hammer and recheck Bearing Pre-Load, If it is correct Stake Adjusting Nut to Shaft by Bend top fo Nut into Groove on Shaft, this will prevent Nut from turning and loosening up.

GEARBOX

P/N 00757825

Assembly Instructions

10. Install Seal (#00758653) into Seal Adapter (#00758652) coat OD of adapter with gasket sealer and ID of Seal with light coat of grease and install Seal Adapter into Horizontal Hub Housing.
11. To Install Output Shaft Housing Assemblies into Main Housing. (DO NOT USE any Gasket sealer at this time) Put Shims and Gasket on Output Housing Assembly and insert it into Main Housing, These shim are used to set Backlash on Gears. Backlash is changed by adding or removing Shims. Tighten Bolts and check Gear Backlash, It should be .017" to .019". When Gear Backlash is correct, Remove Bolts and put Gasket sealer on Gaskets, reinstall Bolts and Lockwashers and tighten down.
12. After both Horizontal Hub Assemblies have been installed, Install To fill Gearbox full of Oil. Fill till Oil runs out of oil level plug in side of gearbox housing. Insert Plugs, oil level plug on side and Vent plug on top. ALWAYS wait enough time for Oil to run inbetween Inner and Out Bearings on Out Put Shaft Assemblies before dicideing Oil Level is Full. After runing mower for 30 minutes to an hour always recheck oil level.

GEARBOX

P/N 00757826

1-3/4" Seal ID with Metal Seal Adapter (Item # 10)

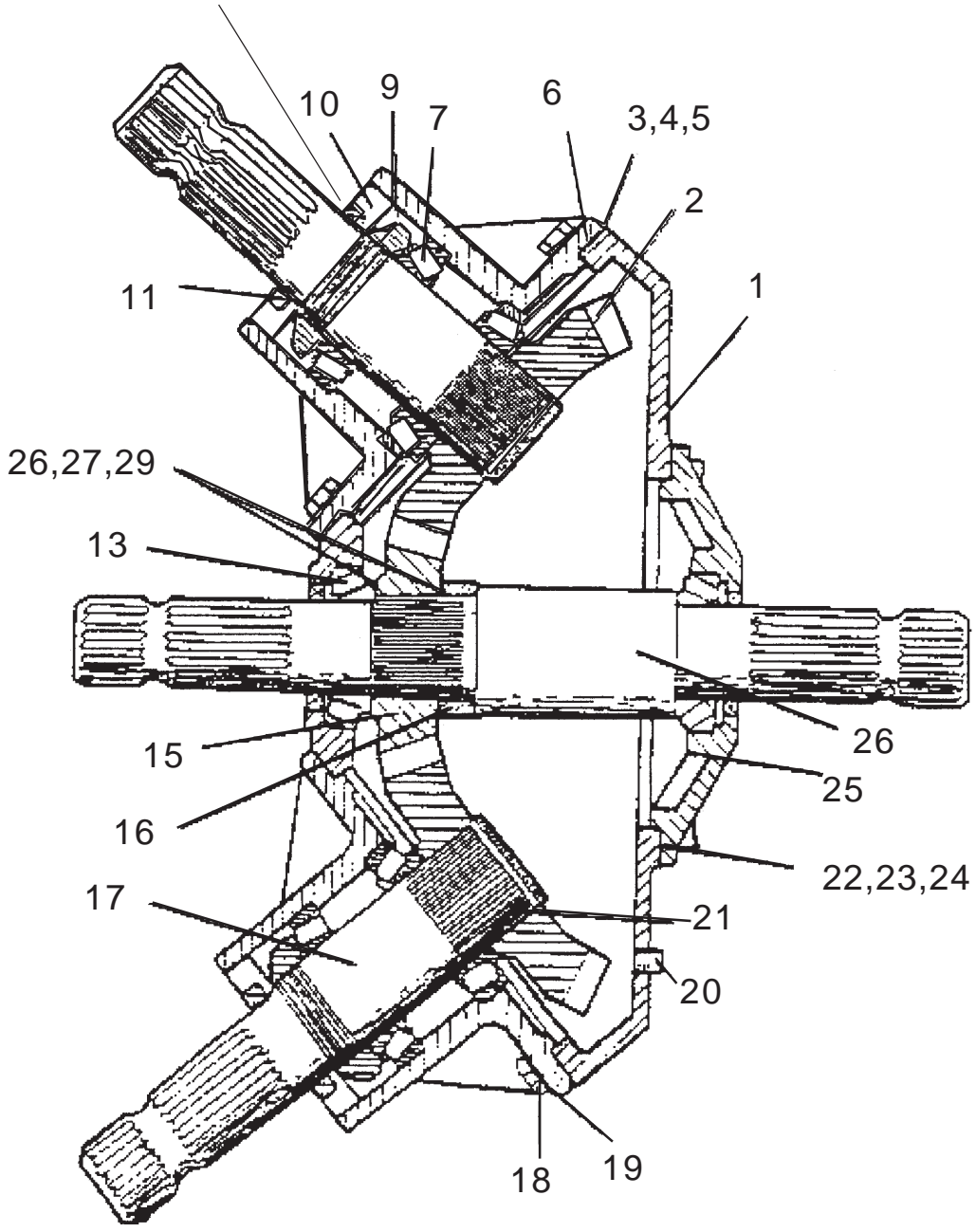

NOTE: To help ID this Gearbox look at Seal for Output Shaft going to the Wing Drivelines. These seals have a 1-3/4" ID and use a Metal Seal adapter (item # 10) at OD of Seals, **These Seal Adapters (item # 10) are only used on this Gearbox.**

GEARBOX

P/N 00757826

Item	Part No.	Qty	Description
	00757826	–	Gearbox Asy (1000 RPM)
1	00758644	1	Housing
2	00758669	2	Gear, 26 Tooth (1000 RPM)
3	00758646	A/R	Shim (.004)
4	00758647	A/R	Shim (.010)
5	00758648	A/R	Shim (.020)
6	00758649	2	Horizontal Hub Cap
7	00758650	4	Bearing
9	00758651	2	Adjusting Nut
10	00758652	2	Seal Adapter
11	00758653	4	Seal
12	00758654	1	Vented Pipe Plug
13	00758655	2	Bearing
15	00758670	1	Gear, 20 Tooth (1000 RPM)
16	00758657	1	Input Shaft Spacer
17	00758658	2	Horizontal Output Shaft
18	00758659	18	Cap Screw
19	00755954	18	Lockwasher
20	00565000	1	Pipe Plug
21	00758660	2	Retaining Ring
22	00758646	A/R	Shim (.004)
23	00758647	A/R	Shim (.010)
24	00758648	A/R	Shim (.020)
25	00758664	1	Input Cap
26	00758665	1	Input Shaft
27	00758666	A/R	Shim (.004)
28	00758667	A/R	Shim (.010)
29	00758668	A/R	Shim (.020)

NOTE: To help ID this Gearbox look at Seal for Output Shaft going to the Wing Drivelines. These seals have a 1-3/4" ID and use a Metal Seal adapter (item # 10) at OD of Seals, **These Seal Adapters (item # 10) are only used on this Gearbox.**

GEARBOX

P/N 00757826

Assembly Instructions

Installation of Parts For Gearbox # 00757826 (1000 rpm)

1. **Install Input Shaft** (Center Shaft), Bearings, Gear in Main Housing (#00758644) install Input shaft before Output Shafts to Wings
2. Install Bearing Cup (#00758655 Cup & Cone) in Main Housing and Bearing Cup (#00758655 Cup & Cone) in front Bearing Carrier Cap (#00758664), Drive Cups in till they bottom out, Check this before continuing. Then Lay Bearing Carrier Cap aside for now.
3. Install Gear Spacer (#00758657) onto Input Shaft, Slide Gear (#00758656 (23 tooth) 540 rpm or #00758670 (20 tooth) 1000 rpm)) onto Input Shaft making sure gear is against Gear Spacer, If Gear is put on backward the assemblies for Wing Output won't fit. Next install Inner Bearing Cone (#00758655 Cup & Cone) and outer Bearing Cone (#00758655 Cup & Cone) on to Shaft making sure inner bearing is bottomed out against gear and outer Bearing Cone is against shoulder on Input Shaft.
4. Install Seal (#00758653) into Bearing Carrier Cap and Seal (#00758653) into rear of Main Housing. Coat ID of Seals with light coat of Grease, using Shims (DO NOT put Gasket Sealer on Shims at this time) Tighten down Bearing Carrier Cap and check Bearing Pre-Load, It should be 14 to 16 inch pounds of rolling torque, Shaft should not have any end play in or out. If less Pre-Load is needed remove Shims if more is needed add shims. If Bearing preload is right, remove Bearing Carrier Cap and coat shims with Sealer and re-install, Tighten Bolts and Recheck Bearing Preload.
5. When this has been Done go on to Step 2, Installing Wing Output Shaft Assembly with Gear. The Gear Backlash will be set at .017" to .019"
6. **Install Output Shaft Asy**, Bearings, Gear (Output) in Horizontal Hub Housing (#00758649) Always install Center Input Shaft in Main Housing first, see step 1.
7. Install Outer Bearing Cup (#00758650 Cup & Cone) and Inner Bearing Cup (#00758650 Cup & Cone) into Horizontal Hub Housing (#00758649), (inner cup near gear and one outer cup near seal), They are the same and can be installed inner or outer Cup, Install cups in Housing till they bottom out against shoulders in Housing.
8. Install Inner Bearing Cone (#00758650 Cup & Cone) onto Output Shaft (# 00757895), Make sure Bearing is seated down against on shaft far enough that Gear can be installed. Install Gear (#00758645 (20 tooth) 540 rpm or #00758669 (26 tooth) 1000 rpm)
9. Install Snap Ring (#00758660) onto Output Shaft (#00758658) this holds gear on Shaft. Insert Shaft with Gear and Bearing on into Horizontal Housing. Install Outer Bearing Cone (#00758650 Cup & Cone) over Output Shaft and into Housing till it seats against Outer Bearing Cup. Screw Bearing Adjusting Nut onto Output Shaft till it touches Bearing Cone. Continue to tighten Bearing Adjusting Nut till Bearings have 14" to 16" pounds of rolling torque. Tap Shaft with a Hammer and recheck Bearing Pre-Load, If it is correct Stake Adjusting Nut to Shaft by Bend top fo Nut into Groove on Shaft, this will prevent Nut from turning and loosening up.

GEARBOX

P/N 00757826

Assembly Instructions

- 10.** Install Seal (#00758653) into Seal Adapter (#00758652) coat OD of adapter with gasket sealer and ID of Seal with light coat of grease and install Seal Adapter into Horizontal Hub Housing.
- 11.** To Install Output Shaft Housing Asemblies into Main Housing. (DO NOT USE any Gasket sealer at this time) Put Shims and Gasket on Output Housing Assembly and insert it into Main Housing, These shim are used to set Backlash on Gears. Backlash is changed by adding or removing Shims. Tighten Bolts and check Gear Backlash, It should be .017" to .019". When Gear Backlash is correct, Remove Bolts and put Gasket sealer on Gaskets, reinstall Bolts and Lockwashers and tighten down.
- 12.** After both Horizontal Hub Assenblies have been installed, Install To fill Gearbox full of Oil. Fill till Oil runs out of oil level plug in side of gearbox housing. Insert Plugs, oil level plug on side and Vent plug on top. ALWAYS wait enough time for Oil to run inbtween Inner and Out Bearings on Out Put Shaft Assemblies before dicideing Oil Level is Full. After runing mower for 30 minutes to an hour always recheck oil level.

GEARBOX

P/N 00757828

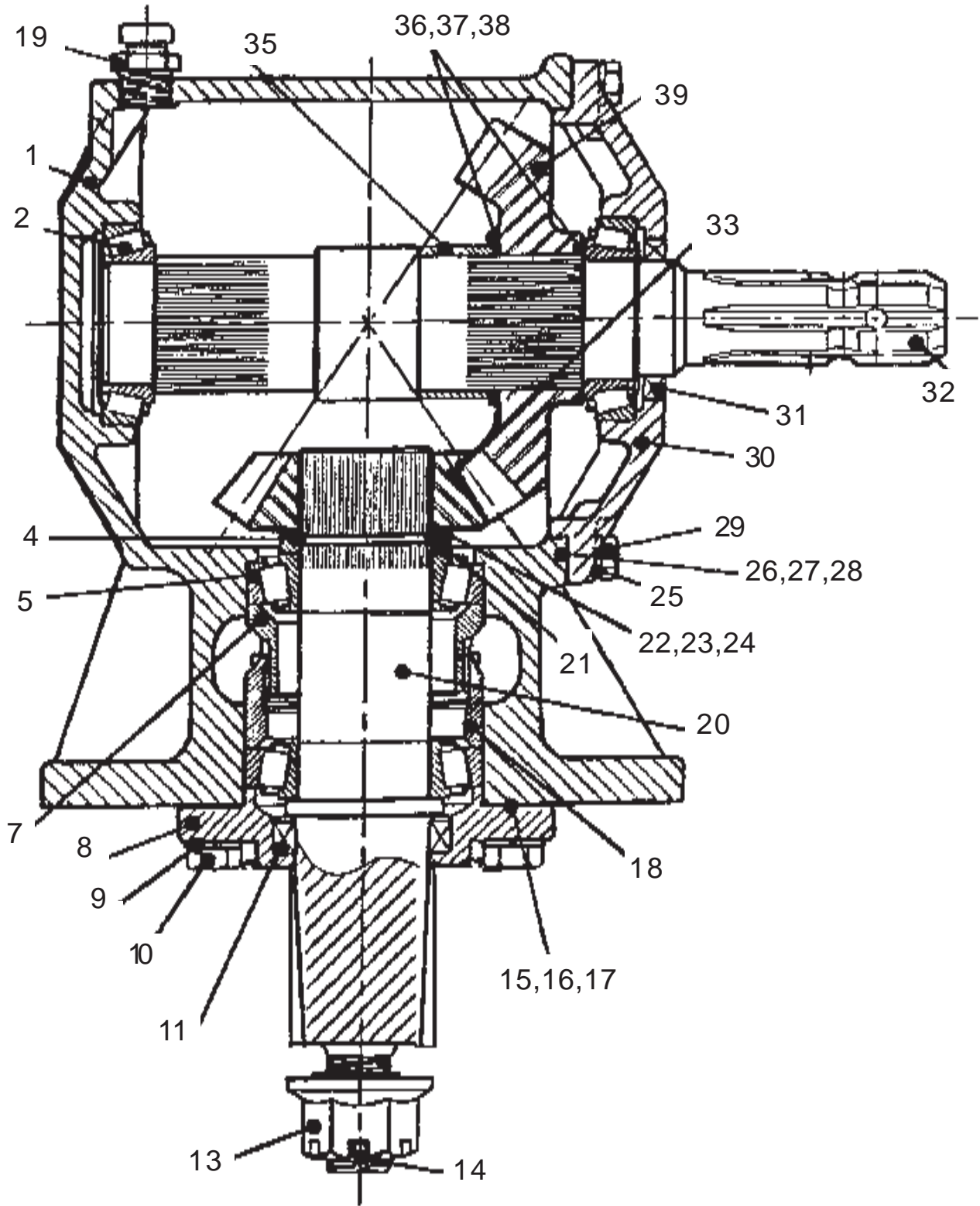

This Gearbox Has a 1-3/8" X 6 Spline Input Shaft
& 2" Tapered Spline Output Shaft & a 2 piece Lower Bearing Spacer

GEARBOX

P/N 00757828

Item	Part No.	Qty	Description
	00757828	1	Gearbox Asy (Use # 00757828B)
1	00758661	1	Housing, Gearbox
2	00758655	2	Bearing, Input Shaft
4	00758660	1	Retaining Ring
5	00758650	2	Bearing, Output Shaft
7*	00758662	1	Bearing Spacer, Upper Half of 2 Piece
8	00758663	1	Bearing Cap, Output
9	00758672	4	Lockwasher
10	00758673	4	Bolt
11	00758674	1	Seal, Output
13	00758692	1	Flange Nut, Special
14	00606000	1	Cotter Pin
15	00758676	2-a/r	Gasket / Shim (0.004" Thick)
16	00758677	1-a/r	Gasket / Shim (0.010" Thick)
17	00758678	1-a/r	Gasket / Shim (0.020" Thick)
18*	00758679	1	Bearing Spacer, Lower Half of 2 Piece
19	00758654	1	Plug, Pressure Relief
20*	00758687	1	Shaft, Output (See Note Below)
21	00758688	1	Retaining Ring
22	00758666	2-a/r	Shim (0.004" Thick)
23	00758667	1-a/r	Shim (0.010" Thick)
24	00758668	1-a/r	Shim (0.020" Thick)
25	00755954	8	Lockwasher
26	00758646	2-a/r	Gasket / Shim (0.004" Thick)
27	00758647	1-a/r	Gasket / Shim (0.010" Thick)
28	00758648	1-a/r	Gasket / Shim (0.020" Thick)
29	00758659	8	Bolt
30	00758664	1	Bearing Cap, Input
31	00758653	1	Seal
32	00758696	1	Shaft, Input (1-3/8" 6 Spline)
33	00758693	1	Gear, Output 13 Tooth (540 RPM)
34	00565000	1	Plug, Oil Level (Not Shown)
35	00758657	1	Spacer, F/ Input Gear
36	00758666	2-a/r	Shim (0.004" Thick)
37	00758667	1-a/r	Shim (0.010" Thick)
38	00758668	1-a/r	Shim (0.020" Thick)
39	00758694	1	Gear, Input 19 Tooth (540 RPM)

* If Replacing Items #7, #18 or #20 it is recommended to Use Output Shaft Replacement Kit #00761517, This will update this Gearbox to the later style Shaft and Nut Type used in later Gearbox # 00757828B. This later Style will be easier to Adjust Bearing Preload. Kit will include Shaft, Nut and one piece Bearing Spacer. Replace Gearbox as an Asy w/ # 00757828B

GEARBOX

P/N 00757828

Assembly Instructions

Assembly Instructions for Gearbox # 00757828 (540 RPM)

- 1. Install Output Shaft** (Blade Shaft), Bearings, Gear in Main Housing (#00758661)
- 2.** Install Lower Bearing Cone (#00758650 Cup & Cone) on Output Shaft (#00758687) make sure Bearing cone slides all the way down against shoulder at bottom of shaft. Slide Bearing Cup (part of #00758650) down over Bearing Cone.
- 3.** Screw the 2 pieces of Bearing Spacer (#00758679 outer & #00758662 inner) together, Screw together BUT DO NOT bend to lock at this time. Slide Bearing Spacers down over Output Shaft. (this 2 piece spacer can be replaced by using Kit #00761517, which replaces Spacer & output shaft with later style)
- 4.** Put Upper Bearing Cup (#00758650 Cup & Cone) over Shaft and slide down till it sits against Bearing Spacer. Slide upper Bearing Cone (#00758650 Cup & Cone) down over Output Shaft till it is against Bearing Cup, Install retaining Rings (#00758688 & #00758660) on Shaft above Upper Bearing Cone. It may be required to shorten Bearing Spaced by screwing it together to get Snap Ring on Shaft.
- 5.** Look at Drawing, If assembled correct the Upper and Lower Bearing Cups and Cone will be on Shaft Opposite each other. Screw Bearing Spacer apart till Bearings have 14" to 16" pounds of rolling Torque Pre-Load. When this is done the Bearing Spacer WILL HAVE TO BE locked, This is done by Bending Outer Bearing Spacer into Inner Bearing Spacer, You will see a groove (looks like keyway) in inner Spacer on threads, This is where you bend Outer Spacer down into this groove. Make SURE it is staked in tight.
- 6.** Slip Shaft with Bearings and Spacer into the Bottom Side of Main Housing, Push into shaft till upper Bearing cup is bottomed out in Main Housing. Install Output Seal (#00758674) into Lower Output Cap (#00758663), Coat ID of Seal with light coat of grease. Using Shims (#00758676, #00758677 and #00758678) quantity may vary and DO NOT USE gasket sealer on shims at this time, Install Output Cap and tighten Bolts. Check Bearing Pre-load, If it is not correct remove or add Shims a needed. When Bearing pre-load is correct remove and coat Shims with a Gasket Sealer then retighten Bolts, Check Bearing Pre-load Again. Output Shaft Should have NO end play inward or outward. and Bearing MUST be set at a rolling Torque.
- 7.** Check and install Shims (#00758666, #00758667 and #00758668) on top of Output Shaft under Gear (#00758693 a 13 tooth gear), try to use same Quantity of shims as came off here. Sit Gear down over Output Shaft and slide down making sure gear is seated against Shims. Later When adjusting Gear Back Lash it may be required to add or remove some of these shims.
- 8. Install Input Shaft** (PTO end), Bearings, Gear in Main Housing (#00758702)
- 9.** Install Gear Spacer (#00758657) Input Shaft. Install Shim (#00758667 & #00758668) on Shaft next to Gear Spacers (the quantity will vary, try to put same as taken off), Slide Input Gear (#00758694 a 19 tooth gear) on front side of shaft or rear of Shaft depending on Left or Right Gearbox till it is against against Shims, Install Front Input Shaft Bearing Cone (#00758655 Cup & Cone) on front of Input Shaft making sure it is against Shims. Install Rear Input Shaft Bearing Cone (#00758650 Cup & Cone) on rear of input Shaft making sure it is against shoulder on Shaft.

GEARBOX

P/N 00757828

Assembly Instructions

- 10.** Install Rear Input Bearing Cup (#00758650 Cup & Cone) into Rear of Main Housing. lower Input Shaft (with Gears, Spacers, Shims and Bearing Cones on it) down into Main housing from front side. Install Bearing Cup (#00758655 Cup & Cone) into Front Input Bearing Cap (#00758664), Install Input Seal (#00758653) into Front Bearing Cap, Coat ID of Seal with light coat of grease. Using Shims (#00758646, #00758647 & #00758648) on front cover set it down over input shaft, Tighten Front cover Bolts.
- 11.** Check Bearing Pre-Load (should be 14" to 16" pounds of rolling Torque) and Gear Back Lash between Blade Shaft Gear and Input Gear (should have .017" to .019" back Lash) If it is not correct, Move Shim from one side of input gear to other to Get Correct Back Lash, It may be required to add or remove shims from Blade Shaft output Gear to raise or lower it to get correct Back lash. Once all is correct Tighten front cover bolts and recheck Gear and Bearing settings.
- 12.** When this has been Done fill Gearbox with Oil, Before deciding Gearbox is full wait long enough for Oil to run down between Output Shaft Bearing, Then refill with Oil, install Oil Plugs and check for leaks, After running Mower 1/2 to 1 hour check Oil Level and recheck for leaks.

GEARBOX P/N 00757828B

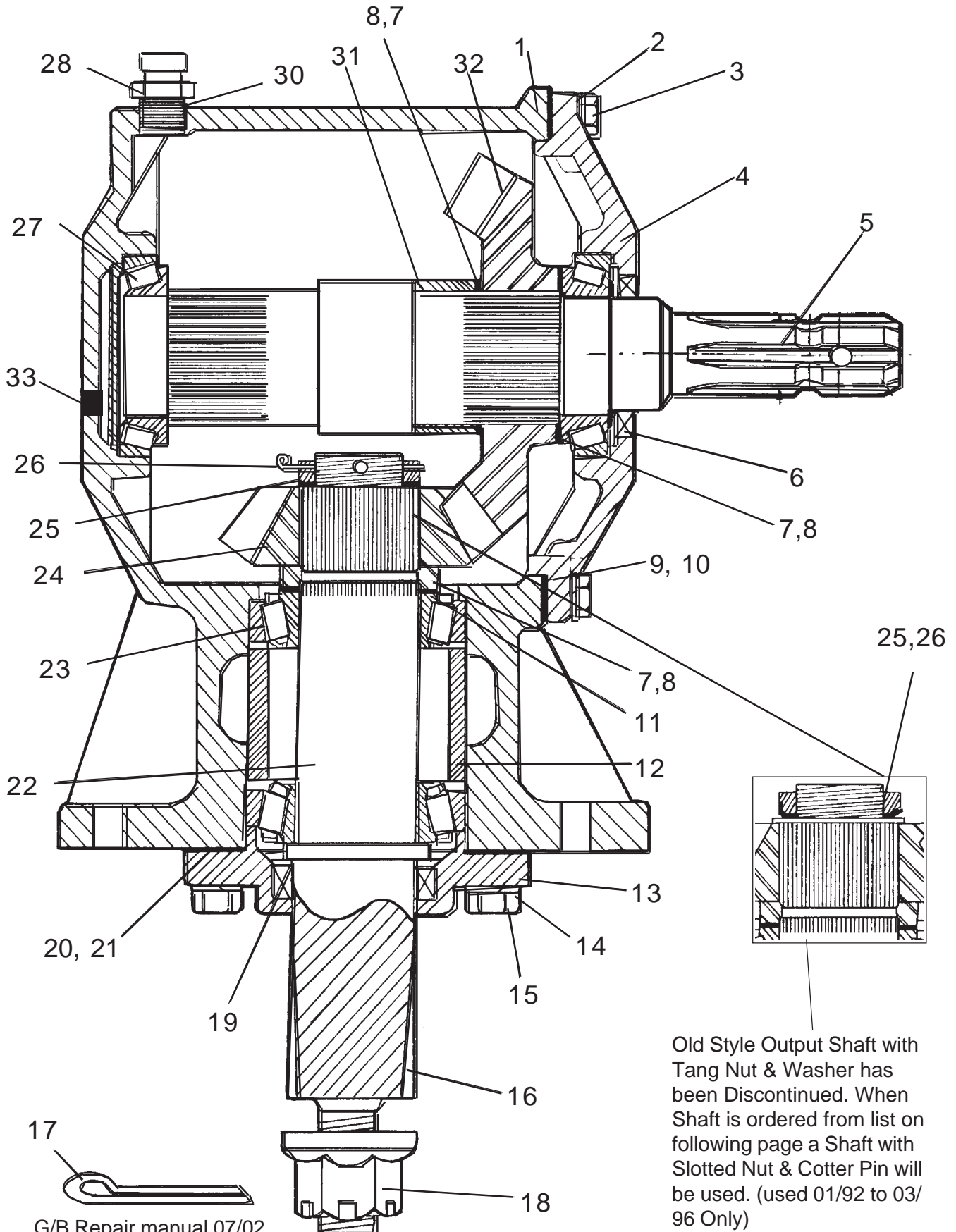

Old Style Output Shaft with Tang Nut & Washer has been Discontinued. When Shaft is ordered from list on following page a Shaft with Slotted Nut & Cotter Pin will be used. (used 01/92 to 03/96 Only)

GEARBOX

P/N 00757828B

Item	Part No.	Qty	Description
	00757828B	1	Gearbox Asy, (540 RPM)
1	00758661	1	Housing
2	00755954	8	Lockwasher
3	00758659	8	Cap Screw
4	00758664	1	Input Cap
5	00758696	1	Input Shaft
6	00758653	1	Oil Seal
7	00758667	2-a/r	Gear Adjusting Shim (0.010" Thick)
8	00758668	1-a/r	Gear Adjusting Shim (0.020" Thick)
9	00758646	2-a/r	Input Cap Gasket (0.004" Thick)
10	00758647	1-a/r	Input Cap Gasket (0.010" Thick)
11	00759977	1	Spacer
12	00760889	1	Spacer
13	00758663	1	Output Cap
14	00758672	4	Lockwasher
15	02959661	4	Cap Screw
16	00758675	1	Blade Hub
17	00606000	1	Cotter Pin
18	00758692	1	Nut
19	00758674	1	Oil Seal
20	00758676	2-a/r	Output Cap Gasket (0.004" Thick)
21	00758677	2-a/r	Output Cap Gasket (0.010" Thick)
22*	00760892	1	Output Shaft
23	00755628	2	Bearing Asy
24	00758693	1	Gear , Output 13 Tooth(540 RPM)
25*	00759970	1	Brg Adjust Nut, Tanged (01/92 to 03/96)
	00762121	1	Brg AdjustNut, Slotted (04/96 to 02/01)
26*	00606000	1	Cotter Pin, (Use w/ Slotted Nut Only)
	00759971	1	Tang Washer, (Use w/ Tang Nut Only)
	00760994	1	Flat Washer, (Use w/ Tang Nut Only)
27	00755615	2	Bearing Asy
28*	00758654	1	Vent Plug (Dia. 0.78 Tapered Thread)
	00762114	1	Vent Plug (Dia. 0.71 Straight Thread) w/ Seal Washer
31	00758657	1	Spacer
32	00758694	1	Gear , Input 19 Tooth (540 RPM)
33*	00565000	1	Oil Level Plug (Sq Head Tapered Thread)
	00762517	1	Oil Level Plug (Allen Head w/ Seal Washer)

NOTE*: # 00760892 Output Shaft will include, Bearing Adjusting Nut, and Cotter Pin. Output Shaft will be type with Slotted Bearing adjusting Nut, If converting from Tang nut to Slotted Nut DO NOT use the Washer that was under Tang Nut. There were two types of Vent & Oil Level Plugs used. To ID which the Straight Thread & Allen Head Plug has a small circle machined around the threaded hole so the Sealing Washer will Seal, the Tapered Threaded & Square Head Plug WILL NOT have this Machined circle around the hole.

This Gearbox Has a 1-3/8" X 6 Spline Input Shaft & a 2" Tapered Spline Output Shaft & a 1 piece Lower Bearing Spacer

GEARBOX

P/N 00757828B

Assembly Instructions

Assembly Instruction Gearbox # 00757828B (540 RPM)

- 1. Install Output Shaft** (Blade Shaft), Bearings, Gear in Main Housing (#00758661)
- Install Lower Bearing Cone (#00758650 Cup & Cone) on Output Shaft (#00760892) make sure Bearing cone slides all the way down against shoulder at bottom of shaft. Slide Bearing Cup (part of #00758650) down over Bearing Cone.
- Install the 1 piece Bearing Spacer (#00760889) down over Output Shaft. Put Upper Bearing Cup (#00758650 Cup & Cone) over Shaft and slide down till it sits against Bearing Spacer. Slide upper Bearing Cone (#00758650 Cup & Cone) down over Output Shaft till it is against Bearing Cup.
- Slip Shaft with Bearings and Spacer into the Bottom Side of Main Housing, Push in shaft till upper Bearing cup is bottomed out in Main Housing.
- Slide Gear Spacer (#00759977) down over Shaft and against Upper Bearing Cone, Install Shims (#00758667 and #00758668) over Shaft, Quantity of Shims will vary, try to use same amount as was taken off. install Output Gear (#00758693 a 13 tooth gear) down over output Shaft. There ARE 2 DIFFERENT types of Bearing Adjusting Nuts used, 1st, Tabbed locking washer and Nut, If this is type used there will be Hardened Flat washer that MUST be install on top of gear, Install Tabbed Locking washer next then Nut. 2 nd type is a Slotted Hex Nut with Cotter Pin, this type WILL NOT use Hardened Flat Washer Nut will go against gear.
- Tighten Bearing Adjusting Nut above Gear till Bearings have 14" to 16" pounds of rolling Torque then Lock Nut, eather with Bendup Tabs or Cotter Pin depending which type you have.
- Install Output Seal (#00758674) into Lower Output Cap (#00758663), Coat ID of Seal with light coat of grease. Using Shims (#00758676, #00758677 and #00758678) quantity may vary according to how large space is between Cap and Main Housing. DO USE gasket sealer on shims at this time, Install Output Cap and tighten Bolts. Check Bearing Pre-load, If correct amount of Shims used it should not have changed. Check Bearing Pre-load Again. Output Shaft Should have NO end play inward or outward. and Bearing MUST be set at a rolling Torque.
- 8. Install Input Shaft** (PTO end), Bearings, Gear in Main Housing (#00758702)
- Install Gear Spacer (#00758657) Input Shaft. Install Shim (#00758667 & #00758668) on Shaft next to Gear Spacers (the quantity will vary, try to put same as taken off), Slide Input Gear (#00758694 a 19 tooth gear) on till it is against against Shims, Install Front Input Shaft Bearing Cone (#00758655 Cup & Cone) on front of Input Shaft making sure it is against Shims. Install Rear Input Shaft Bearing Cone (#00758650 Cup & Cone) on rear of input Shaft making sure it is against shoulder on Shaft.
- Install Rear Input Bearing Cup (#00758650 Cup & Cone) into Rear of Main Housing. lower Input Shaft (with Gears, Spacers, Shims and Bearing Cones on it) down into Main housing from front side. Install Bearing Cup (#00758655 Cup & Cone) into Front Input Bearing Cap (#00758664), Install Input Seal (#00758653) into Front Bearing Cap, Coat ID of Seal with light coat of grease. Using Shims (#00758646, #00758647 & #00758648) on front cover set it down over input shaft, Tighten Front cover Bolts.

GEARBOX

P/N 00757828B

Assembly Instructions

- 11.** Check Bearing Pre-Load (should be 14" to 16" pounds of rolling Torque) and Gear Back Lash between Blade Shaft Gear and Input Gear (should have .017" to .019" back Lash) If it is not correct, Move Shim from one side of input gear to other to Get Correct Back Lash, It may be required to add or remove shims from Blade Shaft output Gear to raise or lower it to get correct Back lash. Once all is correct Tighten front cover bolts and recheck Gear and Bearing settings.
- 12.** When this has been Done fill Gearbox with Oil, Before deciding Gearbox is full wait long enough for Oil to run down between Output Shaft Bearing, Then refill with Oil, install Oil Plugs and check for leaks, After running Mower 1/2 to 1 hour check Oil Level and recheck for leaks.

Gearbox

P/N 00757918

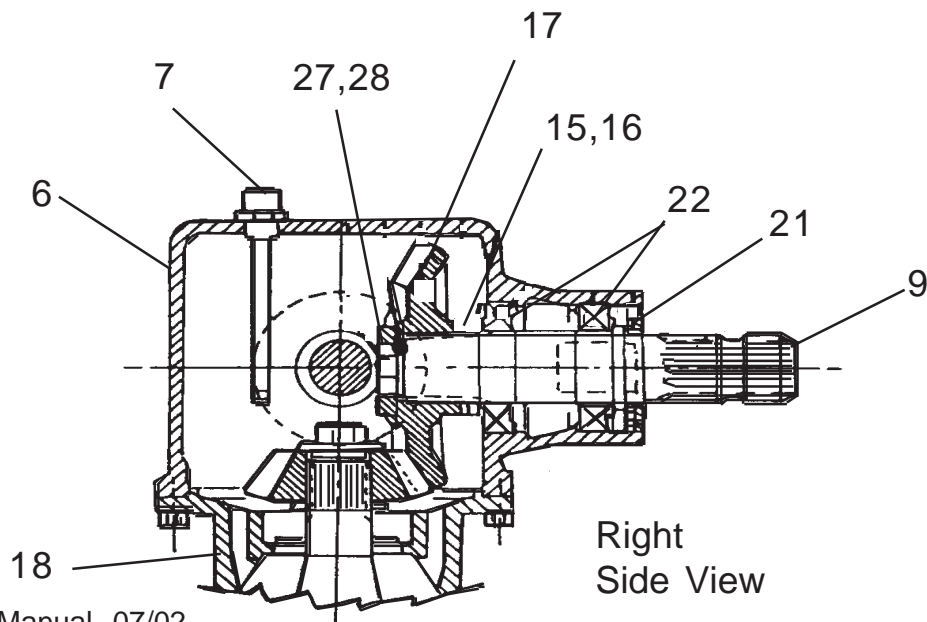
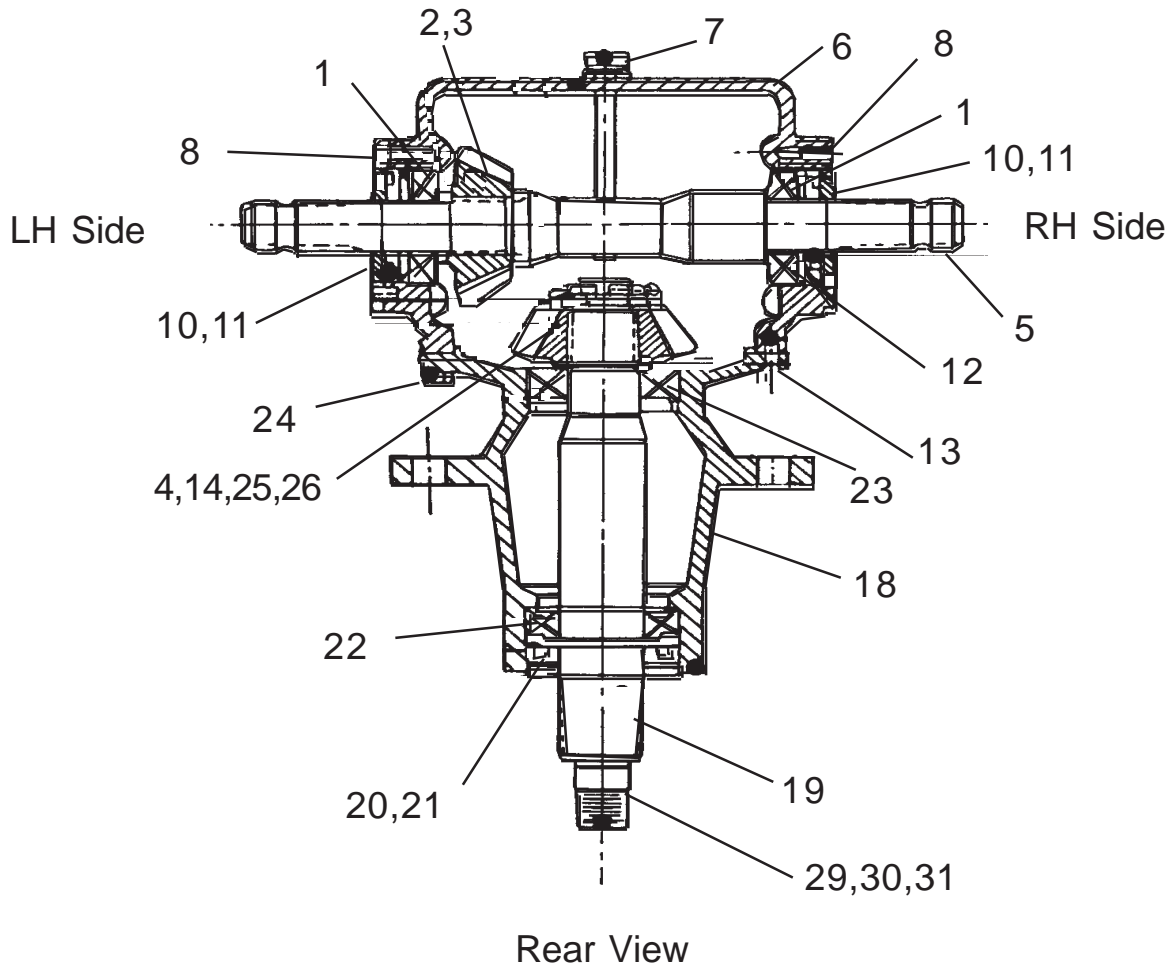

Gearbox

P/N 00757918

Item	Part No.	Qty	Description
	00757918	1	Gearbox Asy 540 RPM
1	00758480	2	Bearing Cup & Cone
2	00758481	1	Shim-Back Gear
3	00758482	2	Pinion Gear
4	00001600	1	Cotter Pin
5	00758487	1	Shaft-Cross
6	00758483	1	Casing, Upper Half
7	00758484	1	Plug-Vent
8	00744338	8	Bolt
9	00758495	1	Shaft-Input
10	00758486	2	Oil Seal
11	00758485	2	Cover-Side Shaft
12	00758488	1	Shim Cross Shaft
13	00758489	2	Spring Pin
14	00758490	1	Shim Lower Gear
15	00758500	1	Shim Input Gear
16	00758491	1	Spacer Input Gear
17	00758499	1	Gear Input
18	00758493	1	Extension Lower
19	00758492	1	Shaft Lower Blade
20	00755626	1	Protective Shield
21	00755627	2	Oil Seal
22	00755628	3	Bearing
23	00758494	1	Bearing Cup & Cone
24	00751688	8	Bolt
25	00758482	2	Pinion Gear
26	00758496	1	Nut
27	00758498	1	Spring Washer
28	00758497	1	Locknut
29	00755623	1	Washer, (Not Shown)
30	00755624	1	Nut (Not, Shown)
31	00606000	1	Cotter Pin, (Not Shown)

Gearbox

P/N 00757918

Assembly Instructions

Installation Part Numbers are for Gearbox #00757918 (540 RPM)

1. **Install Output Shaft (Blade Shaft)**, Shaft, Bearings & Gear in Lower Extension Housing (item 18)
2. Install Upper Bearing Cup (item 23 Cup & Cone) into Lower Housing (item 18) from the top, Install Lower Bearing Cup (item 22) into Lower Housing from the bottom.
3. Install the Lower Bearing Cone (item 22 Cup & Cone) down over Output Shaft. Insert Output Shaft with Bearing Cone on it up through Lower Housing from the bottom. Put Upper Bearing Cone (item 23 Cup & Cone) over Output Shaft and slide down till it bottoms out in upper Bearing Cup.
4. Install Shims (item 14) down over top of Output Shaft, The number of shims required will vary, try to use the same amount as were removed. Install Output Gear (item 25) over Output Shaft, Make sure it is seated against Shim. Screw Slotted Bearing Adjusting Nut (item 26) onto top of Output Shaft. Tighten Bearing Adjusting Nut above Gear till Bearings have 14" to 16" pounds of rolling Torque then secure Bearing Adjusting Nut with Cotter Pin.
5. Install Output Seal (item 21) coating ID of Seal with light coat of grease. Install Seal Protector (item 20) now, Seal Protector (item 20), This Seal Protector Should always be replaced with new one after being removed. Re-Check Bearing Pre-load. Output Shaft Should have NO end play and Bearing MUST be set at a Rolling Torque.
6. **Install Input Shaft (PTO end)**, Shaft, Bearings & Gear into Top Housing (item 6)
7. Install Inner Bearing Cup (item 22 Cup & Cone) in Upper Housing, This will install from inside housing. Install Outer Bearing Cup (item 22 Cup & Cone) from the outside of Housing. Slide Outer Bearing Cone (item 22 Cup & Cone) onto Input Shaft (item 9) from Gear end, Slide Input Shaft with Outer Bearing Cone on it into Housing from the outside. Slide Inner Bearing Cone (item 22 Cup & Cone) onto input shaft from Gear end till it is seated into Bearing Cup.
8. Install Gear Shims (item 15 a/r) onto input shaft from Gear end. Install Gear Spacer (item 16) onto input shaft, Slide Input Gear (item 17) onto input Shaft. Put Spring Washer (item 27) on input shaft. Screw Bearing Adjusting Nut (item 28) onto input Shaft. Tighten Adjusting Nut (item 28) till you achieve a Bearing Preload of 14" to 16" lbs of rolling torque. Install Input Seal (item 21) coating ID of Seal with light coat of grease. Re-Check Bearing Pre-load. Input Shaft Should have NO end play and Bearing MUST be set at a Rolling Torque.
6. **Install Output Shaft (Cross Shaft)**, Shaft, Bearings & Gear into Top Housing (item 6), To do this turn Top Housing upside down on Work Bench.
7. With Input Shaft pointing toward you install R

Gearbox

P/N 00755598

Assembly Instructions

11. When this has been Done fill Gearbox with Oil, Before deciding Gearbox is full wait long enough for Oil to run down between Output Shaft Bearing, Then refill with Oil, install Top Cover (using Sealer for Gasket), Oil Plugs and check for leaks, After running Mower 1/2 to 1 hour check Oil Level and recheck for leaks.

Gearbox

P/N 00758217B

Old Style Apr. 96 & Down

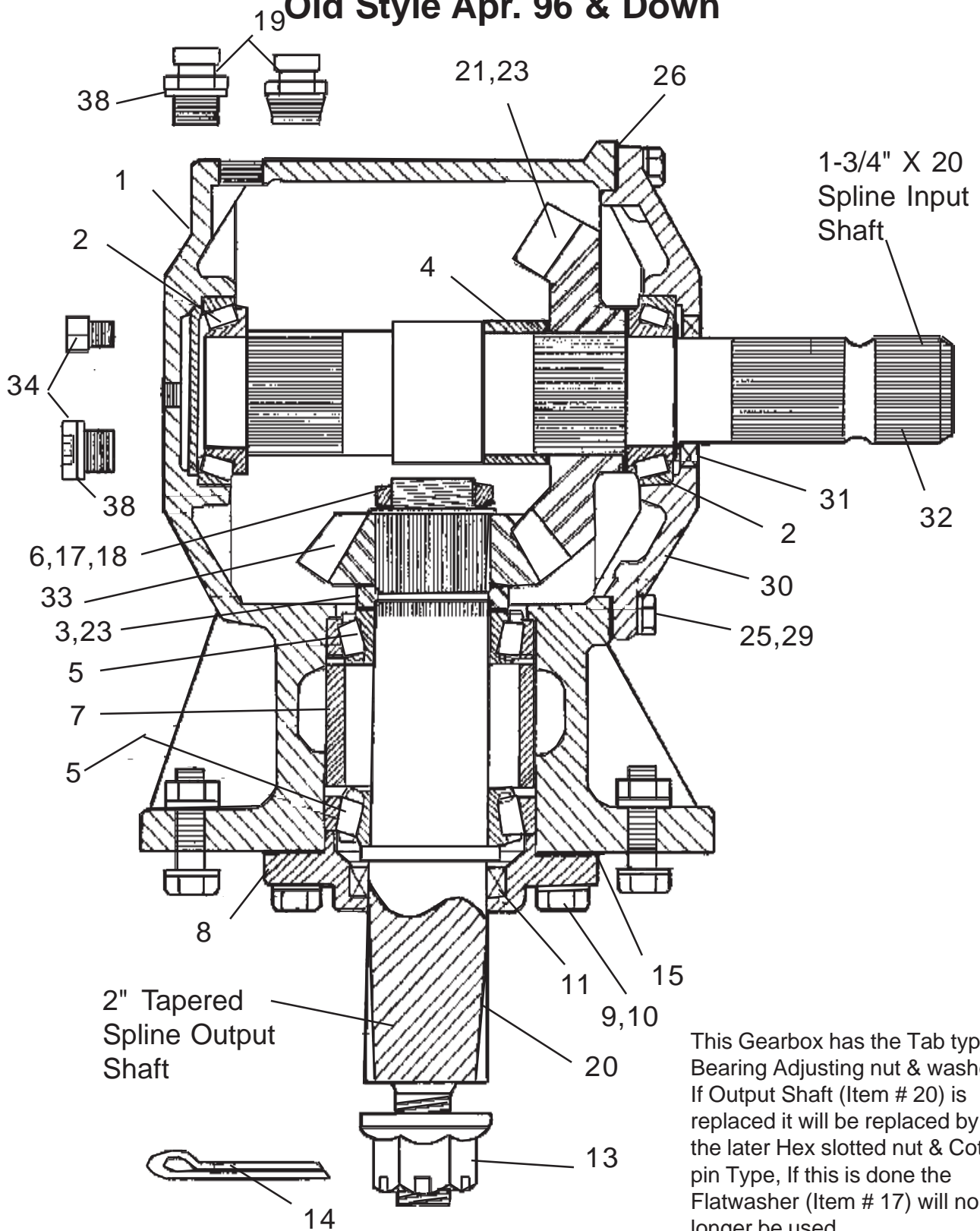

This Gearbox has the Tab type Bearing Adjusting nut & washer, If Output Shaft (Item # 20) is replaced it will be replaced by the later Hex slotted nut & Cotter pin Type, If this is done the Flatwasher (Item # 17) will no longer be used.

Gearbox

P/N 00758217B

Old Style Apr. 96 & Down

Item	Part No.	Qty	Description
	00758217B	--	Gearbox Asy, 1000 RPM
1	00758661	1	Housing-Gearbox
2	00758655	2	Bearing Cup & Cone, Input
3	00759977	1	Gear Spacer, Output
4	00758657	1	Gear Spacer, Input
5	00755628	2	Bear Cup & Cone, Output
6	00759970	1	Bearing Adjusting Nut, Output
7	00760889	1	Bearing Spacer, Output
8	00758663	1	Bearing Cap, Output
9	00758672	4	Lockwasher
10	00758673	4	Bolt
11	00758674	1	Seal, Output Shaft
13	00758692	1	Nut, Blade Carrier Retaining
14	00606000	1	Cotter Pin
15	00758676	a/r	Gasket, Output Cap (.004) Approx 2 Ea.
	00758677	a/r	Gasket, Output Cap (.010) Approx 1 Ea.
17	00760994	1	Flatwasher, Output
18	00759971	1	Locking Washer, Bearing Adjust Nut, Output
19*	00758654	a/r	Pressure Relief Plug, (Tapered Threads)
	00762114	a/r	Pressure Relief Plug, (Straight Threads w/ Sealing Washer)
20	00760892	1	Output Shaft, (Used Tab Nt & Washer on Top)
21	00758693	a/r	Gear, Input 13 Tooth (1000 RPM Only)
23	00758667	a/r	Shim, Output or Input Gear Adjusting (.012) Approx 2 Ea.
	00758668	a/r	Shim, Output or Input Gear Adjusting (.020) Approx 2 Ea.
25	00755954	8	Lockwasher
26	00758646	a/r	Gasket, Input Cap (.004) Approx 2 Ea.
	00758647	a/r	Gasket, Input Cap (.010) Approx 1 Ea.
29	00758659	8	Bolt
30	00758664	1	Bearing Cap, Input
31	00758653	1	Seal, Input Shaft
32	00758689	1	Shaft, Input
33	00758694	a/r	Gear, Output 19 Tooth (1000 RPM Only)
34*	00565000	a/r	Plug, Oil Level, Sq Head (Tapered Thread)
	00762517	a/r	Plug, Oil Level, Allen Head (Straight Thread w/ Sealing Washer)
38	00769321	2	Seal Washer, (Use Only w/ 00762517 or 00762114 Plugs)

NOTE: * There are two different type Plugs, To ID which check Threads & Head Type, Sealing washer or not, Also on type with sealing wwasher there will be a circle machined around hole to make a flat surface for washer to seal. Tapered Threaded Plugs will Not have this machined area.

Gearbox

P/N 00758217B

New Style May 96 & Up

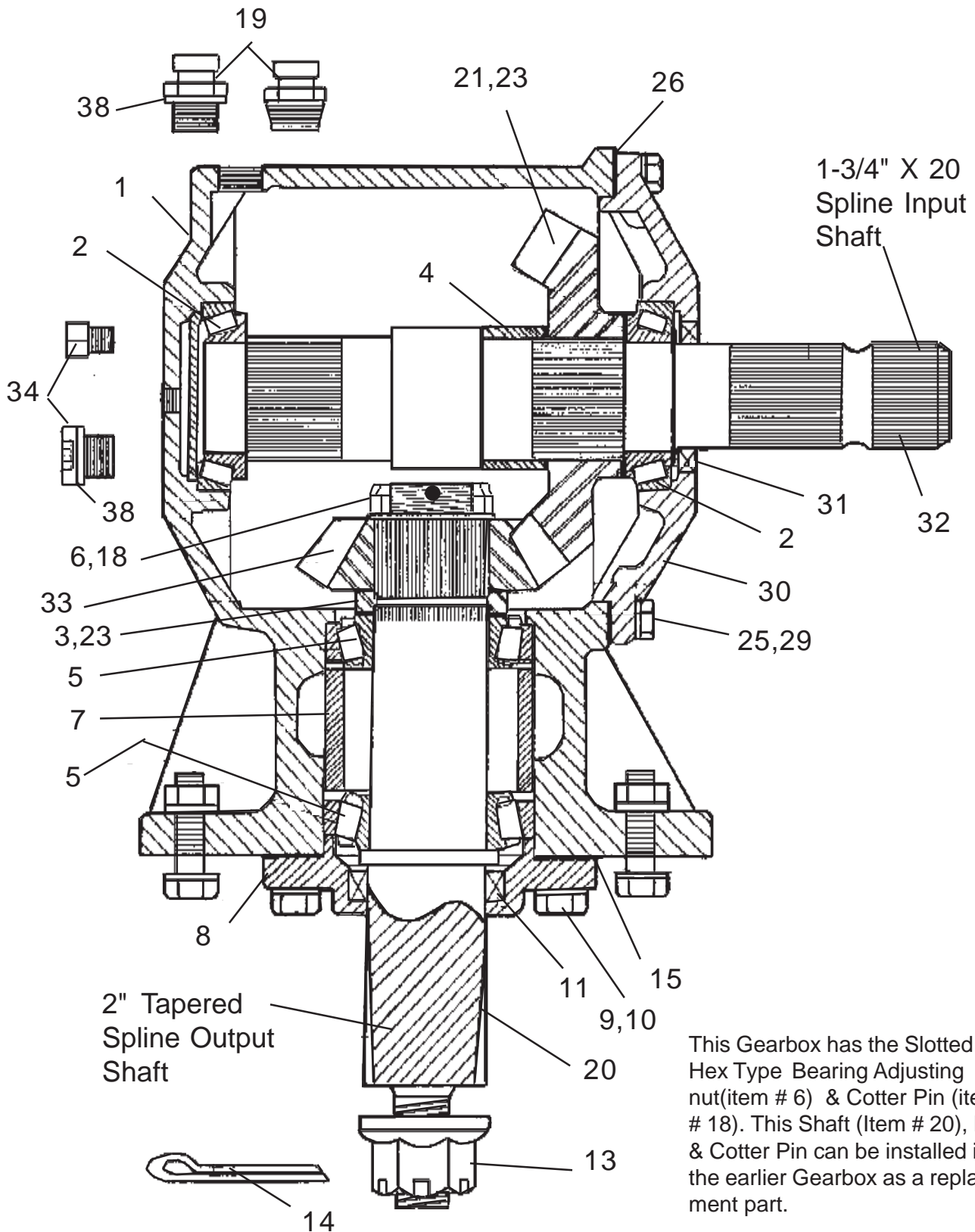

This Gearbox has the Slotted Hex Type Bearing Adjusting nut (item # 6) & Cotter Pin (item # 18). This Shaft (Item # 20), Nut & Cotter Pin can be installed in the earlier Gearbox as a replacement part.

Gearbox

P/N 00758217B

New Style May 96 & Up

Item	Part No.	Qty	Description
	00758217B	--	Gearbox Asy, 1000 RPM
1	00758661	1	Housing-Gearbox
2	00755615	2	Bearing Cup & Cone, Input
3	00759977	1	Gear Spacer, Output
4	00758657	1	Gear Spacer, Input
5	00769938	2	Bear Cup & Cone, Output
6	00759970	1	Bearing Adjusting Nut, Output
7	00760889	1	Bearing Spacer, Output
8	00758663	1	Bearing Cap, Output
9	00758672	4	Lockwasher
10	00758673	4	Bolt
11	00758674	1	Seal, Output Shaft
13	00758692	1	Nut, Blade Carrier Retaining
14	00606000	1	Cotter Pin
15	00758676	a/r	Gasket, Output Cap (.004) Approx 2 Ea.
	00758677	a/r	Gasket, Output Cap (.010) Approx 1 Ea.
18	00749495	1	Cotter Pin, Use w/ Brg Adjusting Nut Item # 6
19*	00758654	a/r	Pressure Relief Plug, (Tapered Threads)
	00762114	a/r	Pressure Relief Plug, (Straight Threads w/ Sealing Washer)
20	00760892	1	Output Shaft (Use Slotted Nut & Cotter Pin on Top)
21	00758693	a/r	Gear, Input 13 Tooth (1000 RPM Only)
23	00758667	a/r	Shim, Output or Input Gear Adjusting (.012) Approx 2 Ea.
	00758668	a/r	Shim, Output or Input Gear Adjusting (.020) Approx 2 Ea.
25	00755954	8	Lockwasher
26	00758646	a/r	Gasket, Input Cap (.004) Approx 2 Ea.
	00758647	a/r	Gasket, Input Cap (.010) Approx 1 Ea.
29	00758659	8	Bolt
30	00758664	1	Bearing Cap, Input
31	00758653	1	Seal, Input Shaft
32	00758689	1	Shaft, Input
33	00758694	a/r	Gear, Output 19 Tooth (1000 RPM Only)
34*	00565000	a/r	Plug, Oil Level, Sq Head (Tapered Thread)
	00762517	a/r	Plug, Oil Level, Allen Head (Straight Thread w/ Sealing Washer)
38	00769321	2	Seal Washer, (Use Only w/ 00762517 or 00762114 Plugs)

NOTE: * There are two different type Plugs, To ID which check Threads & Head Type, Sealing washer or not, Also on type with sealing wwasher there will be a circle machined around hole to make a flat surface for washer to seal. Tapered Threaded Plugs will Not have this machined area.

Gearbox

P/N 00758217B

Assembly Instructions

Assembly Instructions Gearbox # 00758217B (1000 RPM)

1. **Install Output Shaft** (Blade Shaft), Bearings, Gear in Main Housing (#00758661)
2. Install Lower Bearing Cone (#00758650 Cup & Cone) on Output Shaft (#00760892) make sure Bearing cone slides all the way down against shoulder at bottom of shaft. Slide Bearing Cup (part of #00758650) down over Bearing Cone.
3. Install the 1 piece Bearing Spacer (#00760889) down over Output Shaft. Put Upper Bearing Cup (#00758650 Cup & Cone) over Shaft and slide down till it sits against Bearing Spacer. Slide upper Bearing Cone (#00758650 Cup & Cone) down over Output Shaft till it is against Bearing Cup.
4. Slip Shaft with Bearings and Spacer into the Bottom Side of Main Housing, Push in shaft till upper Bearing cup is bottomed out in Main Housing.
5. Slide Gear Spacer (#00759977) down over Shaft and against Upper Bearing Cone, Install Shims (#00758667 and #00758668) over Shaft, Quantity of Shims will vary, try to use same amount as was taken off. install Output Gear (540 or 1000 rpm is different Gear see drawing) down over output Shaft. There ARE 2 DIFFERENT types of Bearing Adjusting Nuts used, 1st, Tabbed locking washer and Nut, If this is type used there will be Hardened Flat washer that MUST be install on top of gear, Install Tabbed Locking washer next then Nut. 2 nd type is a Slotted Hex Nut with Cotter Pin, this type WILL NOT use Hardened Flat Washer Nut will go against gear.
6. Tighten Bearing Adjusting Nut above Gear till Bearings have 14" to 16" pounds of rolling Torque then Lock Nut, eather with Bendup Tabs or Cotter Pin depending witch type you have.
7. Install Output Seal (#00758674) into Lower Output Cap (#00758663), Coat ID of Seal with light coat of grease. Using Shims (#00758676, #00758677 and #00758678) quantity may vary according to how large space is between Cap and Main Housing. DO USE gasket sealer on shims at this time, Install Output Cap and tighten Bolts. Check Bearing Pre-load, If correct amount of Shims used it should not have changed. Check Bearing Pre-load Again. Output Shaft Should have NO end play inward or outward. and Bearing MUST be set at a rolling Torque.
8. **Install Input Shaft** (PTO end), Bearings, Gear in Main Housing (#00758702)
9. Install Gear Spacer (#00758657) Input Shaft. Install Shim (#00758667 & #00758668) on Shaft next to Gear Spacers (the quantity will vary, try to put same as taken off), Slide Input Gear (540 RPM & 1000 RPM Gear Different see drawing), till it is against against Shims, Install Front Input Shaft Bearing Cone (#00758655 Cup & Cone) on front of Input Shaft making sure it is against Shims. Install Rear Input Shaft Bearing Cone (#00758650 Cup & Cone) on rear of input Shaft making sure it is against shoulder on Shaft.
10. Install Rear Input Bearing Cup (#00758650 Cup & Cone) into Rear of Main Housing. lower Input Shaft (with Gears, Spacers, Shims and Bearing Cones on it) down into Main housing from front side. Install Bearing Cup (#00758655 Cup & Cone) into Front Input Bearing Cap (#00758664), Install Input Seal (#00758653) into Front Bearing Cap, Coat ID of Seal with light coat of grease. Using Shims (#00758646, #00758647 & #00758648) on front cover set it down over input shaft, Tighten Front cover Bolts.

Gearbox

P/N 00758217B

Assembly Instructions

- 11.** Check Bearing Pre-Load (should be 14" to 16" pounds of rolling Torque) and Gear Back Lash between Blade Shaft Gear and Input Gear (should have .017" to .019" back Lash) If it is not correct, Move Shim from one side of input gear to other to Get Correct Back Lash, It may be required to add or remove shims from Blade Shaft output Gear to raise or lower it to get correct Back lash. Once all is correct Tighten front cover bolts and recheck Gear and Bearing settings.
- 12.** When this has been Done fill Gearbox with Oil, Before deciding Gearbox is full wait long enough for Oil to run down between Output Shaft Bearing, Then refill with Oil, install Oil Plugs and check for leaks, After running Mower 1/2 to 1 hour check Oil Level and recheck for leaks.

GEARBOX

P/N 00758959

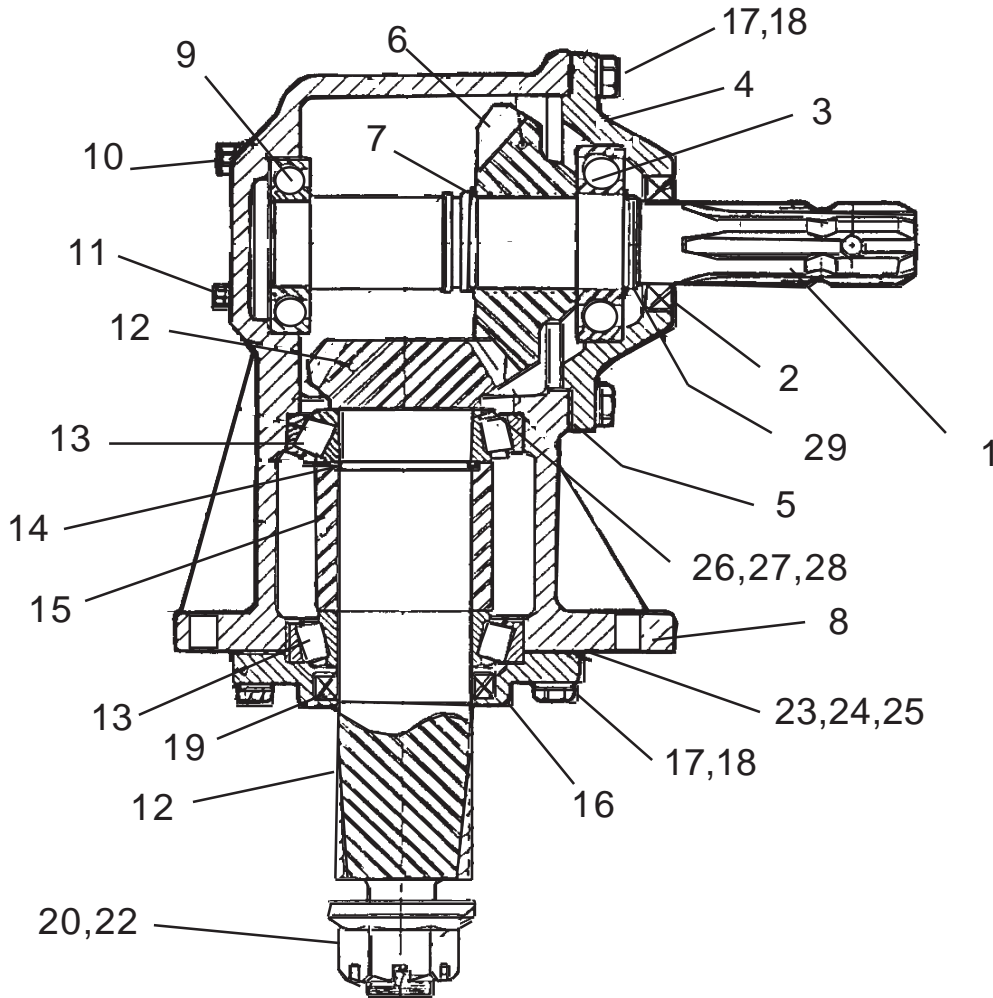

Item	Part No.	Qty	Description	Item	Part No.	Qty	Description
1	00758713	1	Input Shaft	15	00758720	1	Spacer
2	00564200	1	Seal	16	00758721	1	Output Cap
3	00563700	1	Bearing	17	00755954	10	Lockwasher
4	00764949	1	Input Cap	18	00758659	10	Cap Screw
5	00564400	1	Gasket	19	00758674	1	Seal
6	00758729	1	Gear	20	00758692	1	Hex Nut
7	00758715	1	Retaining Ring	22	00606000	1	Cotter Pin
8	00758716	1	Housing	23	00758723	2	Gasket
9	00564800	1	Bearing	24	00758724	2	Gasket
10	00758654	1	Relief Filler Plug	25	00758725	1	Gasket
11	00565000	1	Plug	26	00758726	2	Shim
12	00758730	1	Pinion Gear	27	00758727	2	Shim
13	00758650	2	Bearing	28	00758728	1	Shim
14	00758660	1	Retaining Ring	29	00564100	1	Retaining Ring

G/B Repair Manual 07/02

GEARBOX

P/N 00758959

Assembly Instructions

- 1. Install Output Shaft/Pinion Gear** (item 12) into Main Housing (item 8) install Output Shaft before installing Input Shaft.
- 2.** Install Pinion Shim (item 26,27,28) onto Output shaft from Bottom. Drop upper Output Shaft Bearing Cup (item 13) onto output Shaft (item12), Drop Bearing Cone (item 13) onto Output Shaft, Slide Shims (item 26,27,28) onto Shaft (when installing Shims try Qty that was removed) Install Retaining Snap Ring (item 14) on output Shaft just below upper Bearing and shims, You should have enough Shims (item 26,27,28) that Snap Ring (item 14) holds Bearing, Spacer and Shims snug on Shaft.
- 3.** Install Lower Bearing Space (item 15) on Output Shaft, Note that Bearing Spacer is installed in the correct direction, There is a groove machined in the upper ID to slide over Snap Ring (item 14) if it is not installed this way it will not work.
- 4.** Drop Lower Bearing Cone (item 13) down over Output Shaft, Slide Lower Bearing Cup (item 13) down over Bearing Cone. Slide this completed Output Shaft with components in to the Main Housing (item 8). Make sure that all components are slid in as far as they will go. Using Lower Bearing Cap Shim Gaskets (item 23,24,25) DO NOT put Gasket Sealer on Gaskets yet & DO NOT install lower Seal. Fit Bearing cap with Gasket Shims (item 23,24,25) down over Output Shaft. Add or remove Gasket Shims to Set Bearing Pre-Load in Output Shaft Bearings, Set Bearing Pre-Load from 14 to 16 inch lbs of rolling torque.
- 5.** When Finished with Step 4 go on to installing Input Shaft or if only replacing Output shaft go on to set Gear Back-Lash Step 9.
- 6. Install Input Shaft & Gear.** Install Inner Input Shaft Bearing (item 9) into back of Main Housing (item 6), make sure bearing is seated completely into Housing.
- 7.** Install Retaining Ring (item 7) onto input Shaft (item 1), this is the one nearest the middle of the Shaft (Note there are three grooves here make sure to install it in correct one). Slide Input Gear (item 6) down onto input Shaft (item 1) till it is seated against Retaining Ring (item 7). Slide Outer Input Bearing (item 3) down over Shaft till it seats against Input Gear.
- 8.** Slide shaft w/ components into Gearbox Main Housing. Using Gasket/ Shims (item 5 Don't use gasket sealer or Install Input seal at this time) slide Input Bearing Cap (item 4) on over Input Shaft, Tighten till end Play is removed from Input Shaft by adding or removing gaskets.
- 9.** Gear Back-Lash is set by moving Shims at upper Output Shaft Brg from below Brg to above or Vice Versa. Also it can be changed by removeing or adding Shims (item 7) on Input Shaft. Gear Back-Lash should be from .016" to .019"
- 10.** If Brg Back lash is OK remove Bearing Caps (item 16 & 4), Check Seal areas and install Seal. Use Gasket sealer now if wanted & re-install Brg caps. Re-check Bearing Back Lash & Lower Bearing Pre-Load.
- 11.** Fill Gearbox with oil. DO NOT Fill with Oil above Oil Level Plug. Wait a while let Gearbox sit and have time for Oil to run down into lower Bearings and recheck Oil Level. ALWAYS recheck Oil Level after running Mower 1/2 to 1 hour. Inspect Seals for leaking after filling with Oil and after running 1/2 to 1 hour.

Gearbox

P/N 00758996

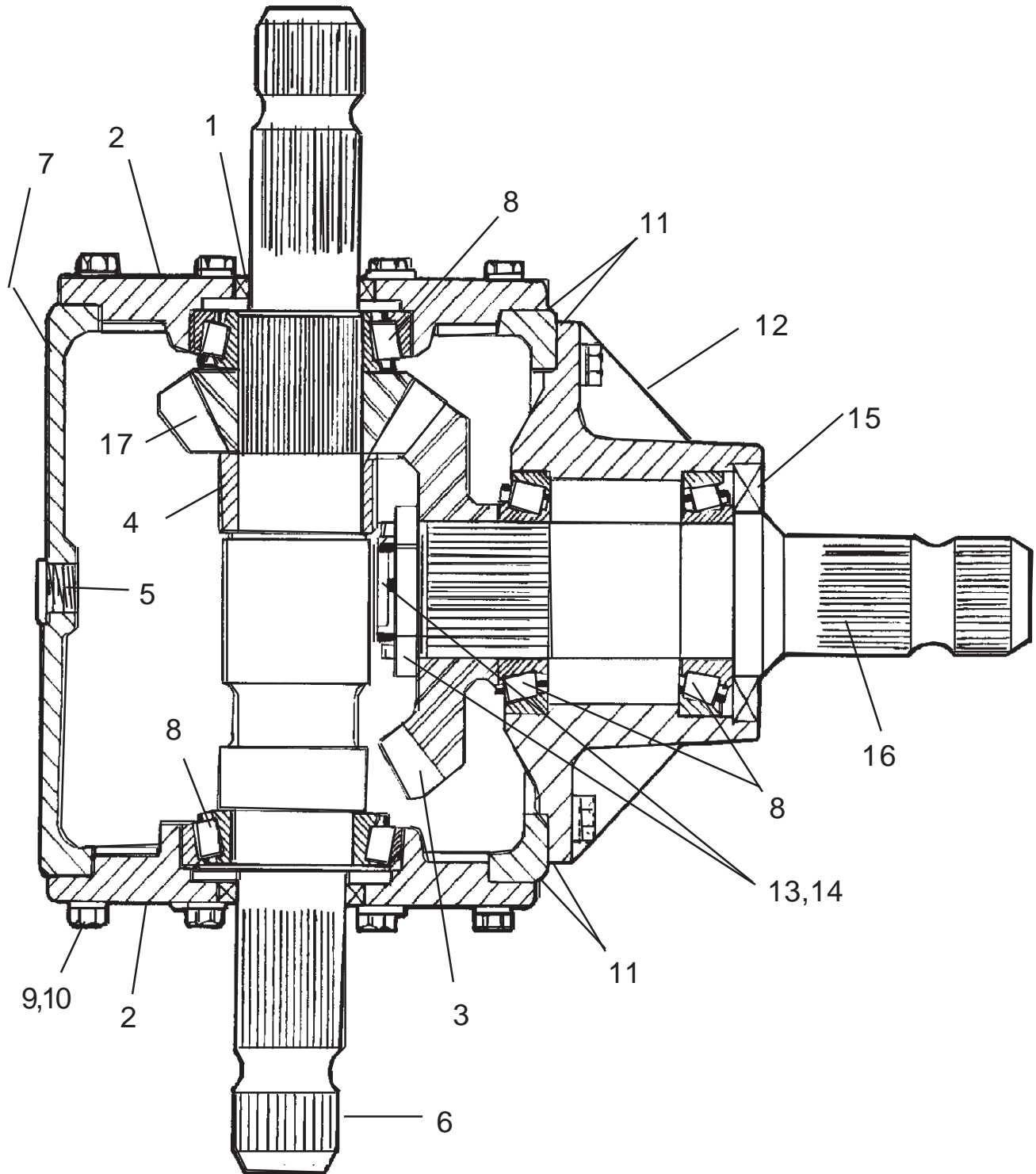

Gearbox

P/N 00758996

Item	Part No.	Qty	Description
	00758996	1	Gearbox Asy, 1000 RPM
1	00758653	2	Seal, Output
2	00762516	2	Cap, Side Cover
3	00759487	1	Gear, 14 Tooth (1000 RPM)
4	00758657	1	Spacer
5	00762517	2	Pipe Plug
6	00762518	1	Shaft, Output
7	00762519	1	Housing
8	00755628	4	Bearing
9	00755954	24	Lockwasher
10	00758659	24	Bolt
11	00748531	a/r	Shim Kit* (0.25, 0.30 & 0.40)
12	00762520	1	Cap, Hub Input Cover
13	00762121	1	Adjusting Nut
14	00026200	1	Cotter Pin
15	00762521	1	Seal, Input
16	00762522	1	Shaft Input
17	00759488	1	Gear, 17 Tooth (1000 RPM)
18	00762114	1	Pipe Plug Vented (not illustrated)

*Shim measurements are in Metric Dimensions mm.
 Inch conversions are 0.25 mm = .009", 0.30 mm = .011" & 0.40 mm = .015"

NOTE: 540 RPM and 1000 RPM Gearbox use same parts except GEARS, To change RPM from 540 to 1000 or vice versa both Gears WILL have to be replaced, Gearbox RPM CAN NOT be changed by reversing Gears. To Check which Gearbox turn input shaft (item # 16) one complete turn, Cross Shaft (item # 6) will turn 1.46 turns for 540 RPM and 0.82 Turns for 1000 RPM for every complete turn input Shaft is turned. The Outboard Gearboxes will turn 1 turn output for every turn input on 540 RPM or 1000 RPM as they use the same gearbox and the Gear Ratio is changed in the Divider Gearbox.

Gearbox

P/N 00768996

Assembly Instructions

Gearbox Output Shaft Installation:
Installation Part Numbers are for Gearbox #00769896 (1000 RPM)

1. **Install Cross Shaft** (Side Drive Shaft), Bearings, Gear in Main Housing (#00762519)
2. Inspect the Hole in Bearing Caps for the Seal in All the openings , remove any sharp edges or burrs before installing Seal, Inspect old Seal to make sure there are no lines cut across the outer dia. of it. If there are this is good sign that burrs exist around hole. Install Bearing Cup (# 00755628 Cup & Cone) and Seal (# 00758653) into both of the 2 Side Bearing Caps (# 00762516), Coat ID of Seals with light coat of Grease.
3. Using Shims from Shim Kit (# 00748531) DO NOT put gasket Sealer on Shims at this time, Install Side Bearing Cap (#00762516) to the Right Side of Main Housing (# 00752519). Tighten Bolts snug.
4. Install Bearing Cone (# 00755628 Cup & Cone) onto Right Side of Cross Shaft (# 00762518) Slide Gear Spacer (# 00755657) on to Left Side of Shaft till it rest against the Shoulder of Shaft.
5. Slide the Output Gear (# 00759488) on to Cross Shaft from Left Side till it is against the Gear Spacer. Slide the other Bearing Cone (# 00755628 Cup & Cone) on against Gear. Coat the Cross Shaft with light coat of Grease at the Seal wear area then Slide Cross Shaft with Bearings, Spacer and Gear into Main housing from the Left Side and into the Bearing Cap bolted on the right side.
6. Using Shims from Shim Kit (# 00748531) DO NOT put gasket Sealer on Shims at this time, Install Side Bearing Cap (# 00762516) to the Left Side of Main Housing (# 00752519). Tighten Bolts snug.
7. Check Bearing Pre-Load it should be 14 to 16 inch pounds of rolling torque, If it is not correct remove or add Shims till it is correct. and re snug Bearing Cap Bolts. DO NOT Use Gasket Sealer on Shims / Gaskets at this time.
8. **Install Input Shaft** (PTO Shaft), Bearings, Gear in Input Hub Housing (#00762520)
9. Inspect the Hole in Bearing Caps for the Seal in All the openings , remove any sharp edges or burrs before installing Seal, Inspect old Seal to make sure there are no lines cut across the outer dia. of it. If there are this is good sign that burrs exist around hole. Install Bearing Cup (# 00755628 Cup & Cone) into both ends of the Input Hub Housing, Besure to install them as shown in drawing so the bearing cones can be installed from the outside. The Input Seal (# 00762521) can be installed now into Input Housing (# 00762520).
10. Slide Bearing Cone (# 00755628 Cup & Cone) onto input shaft from the Gear end, Make sure that Bearing is down against shoulder on Shaft. Put light coat of grease on Shaft at Seal wear area and around the ID of Seal then slide Input Shaft (#00762522) into Input Hub Housing.
11. Slide Bearing Cone (# 00755628 Cup & Cone) onto input Shaft till it is seated in the Bearing Cup. Slide Input Gear (# 00759487) onto Input Shaft till it bottomsout against Bearing Cone.
12. Screw Bearing Adjust Nut (# 00762121) onto Input Shaft, Tighten Nut till Bearings have a Pre-Load of 14 to 16 inch pounds of rolling torgue, Tap end of Shaft lightly with a Hammer to make sure Bearing Cones are seated in Cups and Bearing Cones are seated against Shoulder on Shaft. Recheck Bearing Preload, If it is correct install Cotter Pin (# 00026200)

Gearbox

P/N 00768996

Assembly Instructions

- 13.** Using Shims from Shim Kit (# 00748531) DO NOT put gasket Sealer on Shims at this time, Install Input Hub Housing (# 00762520) in to the front of Main Housing (# 00752519). Tighten Bolts snug.
- 14.** Check Gear Back-Lash, it should be from .017" to .019", To Set Back-Lash the Shims for the Input Hub Housing will need to be removed or more added as needed. Also the wear pattern of the Gears should be checked, This can be changed by moving Shims on the two Cross Shaft Bearing Caps from one side or the other. DO NOT remove them completely, if you remove one from one side it must be moved to the other side, this will move the cross shaft gear closer or further away from input gear and keep the correct Bearing Pre-Load.
- 15.** When all Setting are correct remoce housings and caps, use sealer on shims if desired and Re-Check all the Bolts to make sure they are tight. recheck all Settings one more time.
- 16.** Fill Gearbox with Oil, Before deciding Gearbox is full wait long enough for Oil to run down between Shafts and Bearing, Then refill with Oil, Install all Oil Fill & Vent Plugs, Check for leaks, After running Mower 1/2 to 1 hour check Oil Level and recheck for leaks.

Gearbox

P/N 00759205B & 007592206B

Old Style Apr. 96 & Down

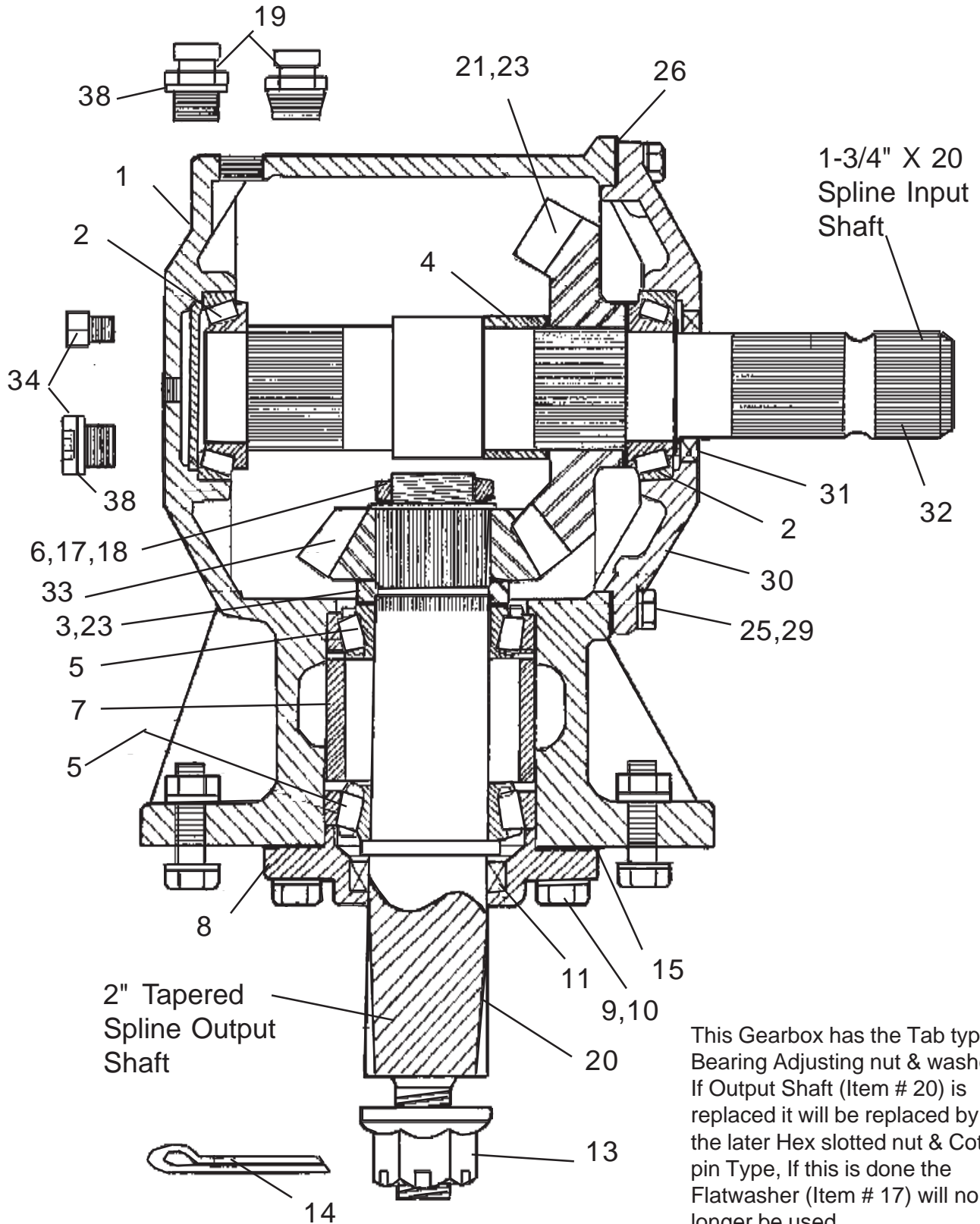

This Gearbox has the Tab type Bearing Adjusting nut & washer, If Output Shaft (Item # 20) is replaced it will be replaced by the later Hex slotted nut & Cotter pin Type, If this is done the Flatwasher (Item # 17) will no longer be used.

Gearbox

P/N 00759205B & 00759206B

Old Style Apr. 96 & Down

Item	Part No.	Qty	Description
	00759205B	--	Gearbox Asy, (Input Gear Mounts in Front) as Shown
	00759206B	--	Gearbox Asy, (Input Gear Mounts in Back) not Shown
1	00758661	1	Housing-Gearbox
2	00758655	2	Bearing Cup & Cone, Input
3	00759977	1	Gear Spacer, Output
4	00758657	1	Gear Spacer, Input
5	00755628	2	Bear Cup & Cone, Output
6	00759970	1	Bearing Adjusting Nut, Output
7	00760889	1	Bearing Spacer, Output
8	00758663	1	Bearing Cap, Output
9	00758672	4	Lockwasher
10	00758673	4	Bolt
11	00758674	1	Seal, Output Shaft
13	00758692	1	Nut, Blade Carrier Retaining
14	00606000	1	Cotter Pin
15	00758676	a/r	Gasket, Output Cap (.004) Approx 2 Ea.
	00758677	a/r	Gasket, Output Cap (.010) Approx 1 Ea.
17	00760994	1	Flatwasher, Output
18	00759971	1	Locking Washer, Bearing Adjust Nut, Output
19*	00758654	a/r	Pressure Relief Plug, (Tapered Threads)
	00762114	a/r	Pressure Relief Plug, (Straight Threads w/ Sealing Washer)
20	00760892	1	Output Shaft, (Used Tab Nt & Washer on Top)
21	00758693	a/r	Gear, Input 13 Tooth (540 or 1000 RPM)
23	00758667	a/r	Shim, Output or Input Gear Adjusting (.012) Approx 2 Ea.
	00758668	a/r	Shim, Output or Input Gear Adjusting (.020) Approx 2 Ea.
25	00755954	8	Lockwasher
26	00758646	a/r	Gasket, Input Cap (.004) Approx 2 Ea.
	00758647	a/r	Gasket, Input Cap (.010) Approx 1 Ea.
29	00758659	8	Bolt
30	00758664	1	Bearing Cap, Input
31	00758653	1	Seal, Input Shaft
32	00758689	1	Shaft, Input
33	00758694	a/r	Gear, Output 19 Tooth (540 or 1000 RPM)
34*	00565000	a/r	Plug, Oil Level, Sq Head (Tapered Thread)
	00762517	a/r	Plug, Oil Level, Allen Head (Straight Thread w/ Sealing Washer)
38	00769321	2	Seal Washer, (Use Only w/ 00762517 or 00762114 Plugs)

NOTE: * There are two different type Plugs, To ID which check Threads & Head Type, Sealing washer or not, Also on type with sealing wwasher there will be a circle machined around hole to make a flat surface for washer to seal. Tapered Threaded Plugs will Not have this machined area.

Gearbox

P/N 00759205B & 007592206B

New Style May 96 & UP

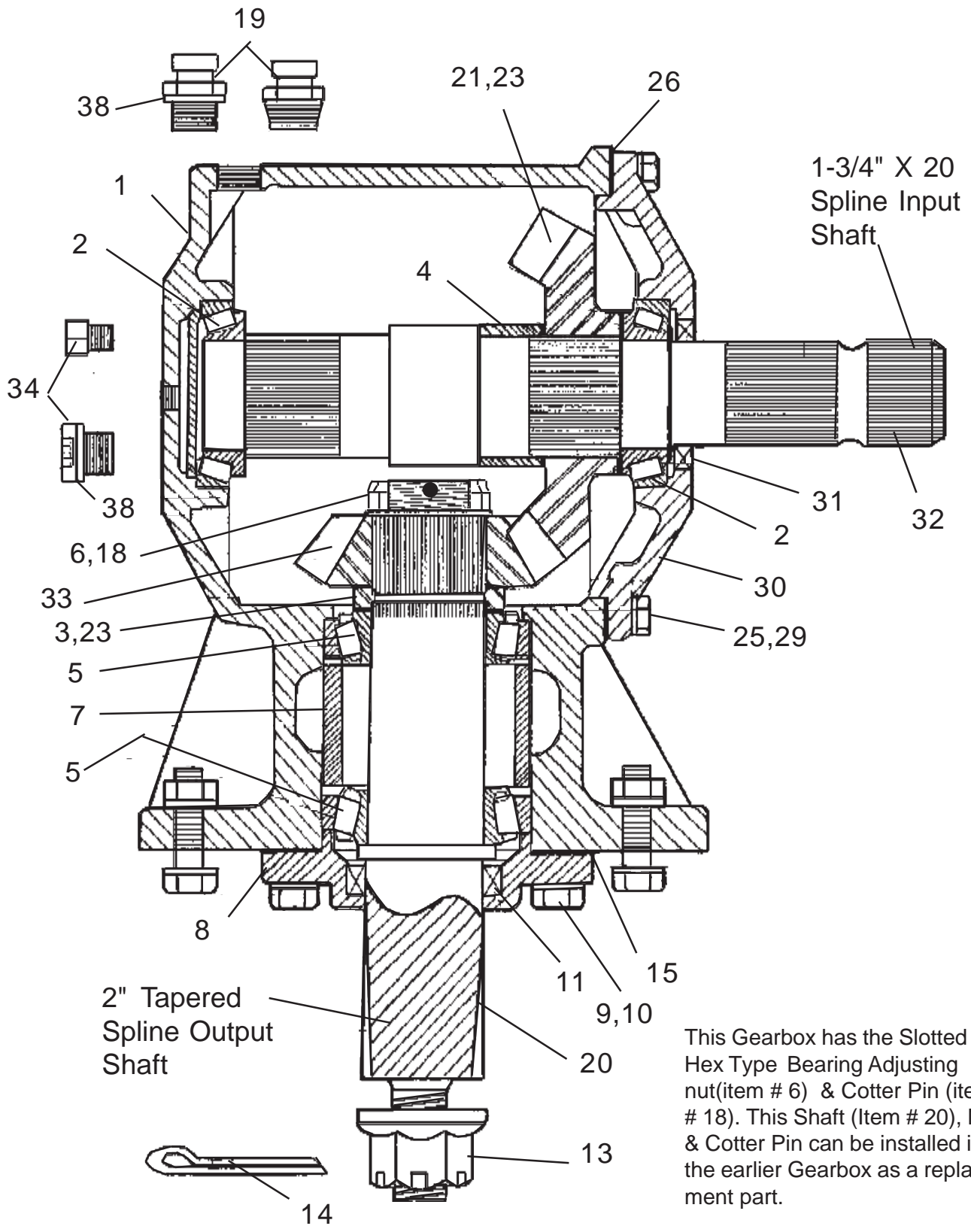

This Gearbox has the Slotted Hex Type Bearing Adjusting nut (item # 6) & Cotter Pin (item # 18). This Shaft (Item # 20), Nut & Cotter Pin can be installed in the earlier Gearbox as a replacement part.

Gearbox

P/N 00759205B & 00759206B

New Style May 96 & Up

Item	Part No.	Qty	Description
	00759205B	--	Gearbox Asy, (Input Gear Mounts in Front) as Shown
	00759206B	--	Gearbox Asy, (Input Gear Mounts in Back) not Shown
1	00758661	1	Housing-Gearbox
2	00758655	2	Bearing Cup & Cone, Input
3	00759977	1	Gear Spacer, Output
4	00758657	1	Gear Spacer, Input
5	00755628	2	Bearing Cup & Cone, Output
6	00770730	1	Bearing Adjusting Nut, Output
7	00760889	1	Bearing Spacer, Output
8	00758663	1	Bearing Cap, Output
9	00758672	4	Lockwasher
10	00758673	4	Bolt
11	00758674	1	Seal, Output Shaft
13	00758692	1	Nut, Blade Carrier Retaining
14	00606000	1	Cotter Pin
15	00758676	a/r	Gasket, Output Cap (.004) Approx 2 Ea.
	00758677	a/r	Gasket, Output Cap (.010) Approx 1 Ea.
18	00771620	1	Cotter Pin, Use w/ Brg Adjusting Nut Item # 6
19*	00758654	a/r	Pressure Relief Plug, (Tapered Threads)
	00762114	a/r	Pressure Relief Plug, (Straight Threads w/ Sealing Washer)
20	00760892	1	Output Shaft (Use Slotted Nut & Cotter Pin on Top)
21	00758693	a/r	Gear, Input 13 Tooth (540 or 1000 RPM)
23	00758667	a/r	Shim, Output or Input Gear Adjusting (.012) Approx 2 Ea.
	00758668	a/r	Shim, Output or Input Gear Adjusting (.020) Approx 2 Ea.
25	00755954	8	Lockwasher
26	00758646	a/r	Gasket, Input Cap (.004) Approx 2 Ea.
	00758647	a/r	Gasket, Input Cap (.010) Approx 1 Ea.
29	00758659	8	Bolt
30	00758664	1	Bearing Cap, Input
31	00758653	1	Seal, Input Shaft
32	00758689	1	Shaft, Input
33	00758694	a/r	Gear, Output 19 Tooth (540 or 1000 RPM)
34*	00565000	a/r	Plug, Oil Level, Sq Head (Tapered Thread)
	00762517	a/r	Plug, Oil Level, Allen Head (Straight Thread w/ Sealing Washer)
38	00769321	2	Seal Washer, (Use Only w/ 00762517 or 00762114 Plugs)

NOTE: * There are two different type Plugs, To ID which check Threads & Head Type, Sealing washer or not, Also on type with sealing washer there will be a circle machined around hole to make a flat surface for washer to seal. Tapered Threaded Plugs will Not have this machined area.

Gearbox

P/N 00759205B & 00759206B

Assembly Instructions

Assembly Instructions Gearbox #00759025B & 00759206B
(540 RPM or 1000 RPM)

1. **Install Output Shaft** (Blade Shaft), Bearings, Gear in Main Housing (#00758661)
2. Install Lower Bearing Cone (#00758650 Cup & Cone) on Output Shaft (#00760892) make sure Bearing cone slides all the way down against shoulder at bottom of shaft. Slide Bearing Cup (part of #00758650) down over Bearing Cone.
3. Install the 1 piece Bearing Spacer (#00760889) down over Output Shaft. Put Upper Bearing Cup (#00758650 Cup & Cone) over Shaft and slide down till it sits against Bearing Spacer. Slide upper Bearing Cone (#00758650 Cup & Cone) down over Output Shaft till it is against Bearing Cup.
4. Slip Shaft with Bearings and Spacer into the Bottom Side of Main Housing, Push in shaft till upper Bearing cup is bottomed out in Main Housing.
5. Slide Gear Spacer (#00759977) down over Shaft and against Upper Bearing Cone, Install Shims (#00758667 and #00758668) over Shaft, Quantity of Shims will vary, try to use same amount as was taken off. install Output Gear (540 or 1000 rpm is different Gear see drawing) down over output Shaft. There ARE 2 DIFFERENT types of Bearing Adjusting Nuts used, 1st, Tabbed locking washer and Nut, If this is type used there will be Hardened Flat washer that MUST be install on top of gear, Install Tabbed Locking washer next then Nut. 2 nd type is a Slotted Hex Nut with Cotter Pin, this type WILL NOT use Hardened Flat Washer Nut will go against gear.
6. Tighten Bearing Adjusting Nut above Gear till Bearings have 14" to 16" pounds of rolling Torque then Lock Nut, eather with Bendup Tabs or Cotter Pin depending witch type you have.
7. Install Output Seal (#00758674) into Lower Output Cap (#00758663), Coat ID of Seal with light coat of grease. Using Shims (#00758676, #00758677 and #00758678) quanity may vary according to how large space is between Cap and Main Housing. DO USE gasket sealer on shims at this time, Install Output Cap and tighten Bolts. Check Bearing Pre-load, If correct amount of Shims used it should not have changed. Check Bearing Pre-load Again. Output Shaft Should have NO end play inward or outward. and Bearing MUST be set at a rolling Torque.
8. **Install Input Shaft** (PTO end), Bearings, Gear in Main Housing (#00758702)
9. Install Gear Spacer (#00758657) Input Shaft. Install Shim (#00758667 & #00758668) on Shaft next to Gear Spacers (the quanity will vary, try to put same as taken off), Slide Input Gear (540 RPM & 1000 RPM Gear Different see drawing), till it is against against Shims, Install Front Input Shaft Bearing Cone (#00758655 Cup & Cone) on front of Input Shaft making sure it is against Shims. Install Rear Input Shaft Bearing Cone (#00758650 Cup & Cone) on rear of input Shaft making sure it is against shoulder on Shaft.
10. Install Rear Input Bearing Cup (#00758650 Cup & Cone) into Rear of Main Housing. lower Input Shaft (with Gears, Spacers, Shims and Bearing Cones on it) down into Main housing from front side. Install Bearing Cup (#00758655 Cup & Cone) into Front Input Bearing Cap (#00758664), Install Input Seal (#00758653) into Front Bearing Cap, Coat ID of Seal with light coat of grease. Using Shims (#00758646, #00758647 & #00758648) on front cover set it down over input shaft, Tighten Front cover Bolts.

Gearbox

P/N 00759205B & 00759206B

Assembly Instructions

- 11.** Check Bearing Pre-Load (should be 14" to 16" pounds of rolling Torque) and Gear Back Lash between Blade Shaft Gear and Input Gear (should have .017" to .019" back Lash) If it is not correct, Move Shim from one side of input gear to other to Get Correct Back Lash, It may be required to add or remove shims from Blade Shaft output Gear to raise or lower it to get correct Back lash. Once all is correct Tighten front cover bolts and recheck Gear and Bearing settings.
- 12.** When this has been Done fill Gearbox with Oil, Before deciding Gearbox is full wait long enough for Oil to run down between Output Shaft Bearing, Then refill with Oil, install Oil Plugs and check for leaks, After running Mower 1/2 to 1 hour check Oil Level and recheck for leaks.

Gearbox

P/N 00760403B, 00750506B & 00750507B

Old Style Apr. 96 & Down

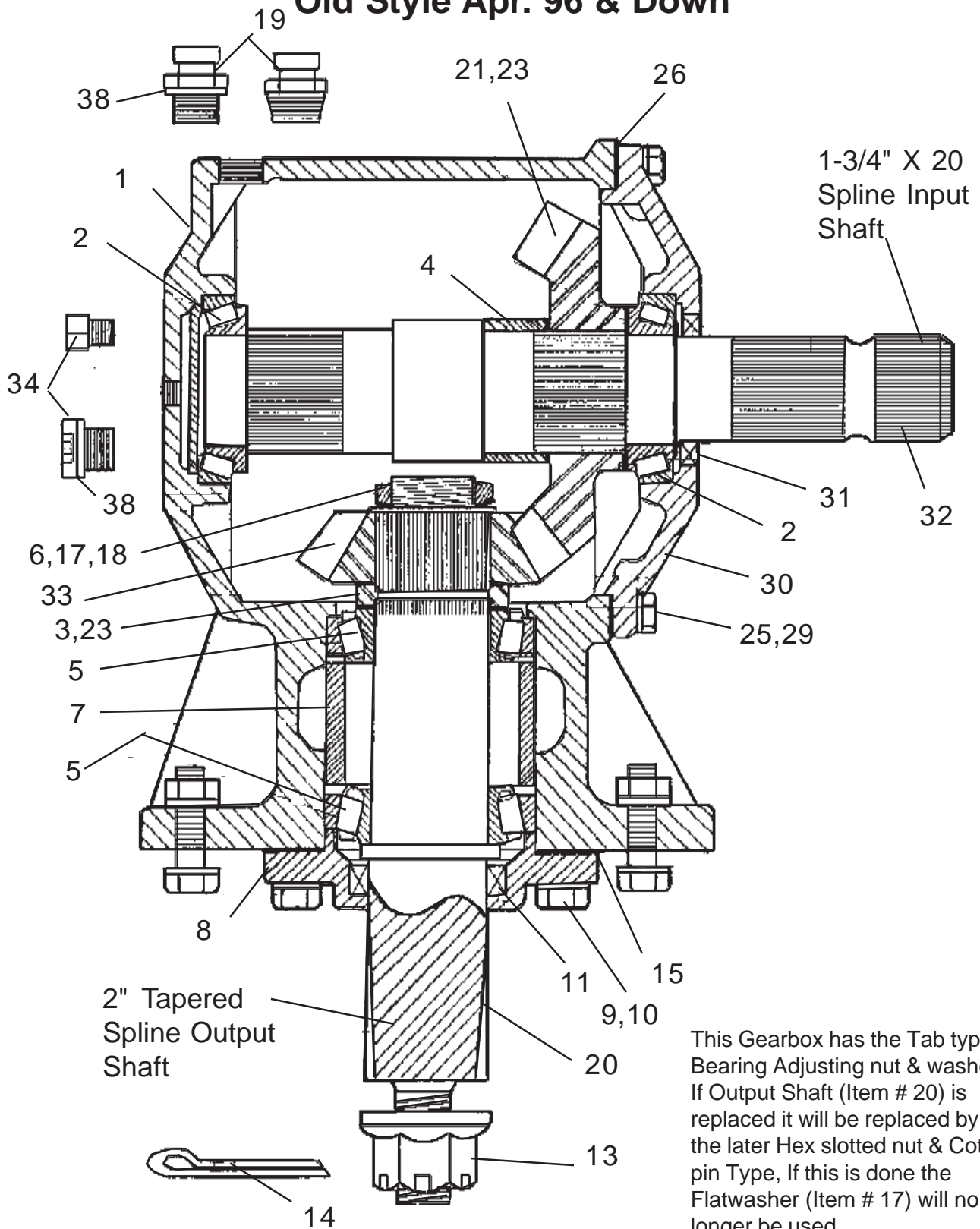

This Gearbox has the Tab type Bearing Adjusting nut & washer, If Output Shaft (Item # 20) is replaced it will be replaced by the later Hex slotted nut & Cotter pin Type, If this is done the Flatwasher (Item # 17) will no longer be used.

Gearbox

P/N 00760403B, 00750506B & 00750507B

Old Style Apr. 96 & Down

Item	Part No.	Qty	Description
	00760403B	--	Gearbox Asy, 540 RPM (input Gear in Front(As Shown)
	00760506B	--	Gearbox Asy, 1000 RPM (input Gear in Front (As Shown)
	00760507B	--	Gearbox Asy, 540 RPM (inout Gear in Back (Not Shaow)
1	00758661	1	Housing-Gearbox
2	00758655	2	Bearing Cup & Cone, Input
3	00759977	1	Gear Spacer, Output
4	00758657	1	Gear Spacer, Input
5	00755628	2	Bear Cup & Cone, Output
6	00759970	1	Bearing Adjusting Nut, Output
7	00760889	1	Bearing Spacer, Output
8	00758663	1	Bearing Cap, Output
9	00758672	4	Lockwasher
10	00758673	4	Bolt
11	00758674	1	Seal, Output Shaft
13	00758692	1	Nut, Blade Carrier Retaining
14	00606000	1	Cotter Pin
15	00758676	a/r	Gasket, Output Cap (.004) Approx 2 Ea.
	00758677	a/r	Gasket, Output Cap (.010) Approx 1 Ea.
17	00760994	1	Flatwasher, Output
18	00759971	1	Locking Washer, Bearing Adjust Nut, Output
19*	00758654	a/r	Pressure Relief Plug, (Tapered Threads)
	00762114	a/r	Pressure Relief Plug, (Straight Threads w/ Sealing Washer)
20	00760892	1	Output Shaft, (Used Tab Nt & Washer on Top)
21	00759488	a/r	Gear, Input 17 Tooth (540 RPM)
	00759487	1	Gear, Input 14 Tooth (1000 RPM)
23	00758667	a/r	Shim, Output or Input Gear Adjusting (.012) Approx 2 Ea.
	00758668	a/r	Shim, Output or Input Gear Adjusting (.020) Approx 2 Ea.
25	00755954	8	Lockwasher
26	00758646	a/r	Gasket, Input Cap (.004) Approx 2 Ea.
	00758647	a/r	Gasket, Input Cap (.010) Approx 1 Ea.
29	00758659	8	Bolt
30	00758664	1	Bearing Cap, Input
31	00758653	1	Seal, Input Shaft
32	00758689	1	Shaft, Input
33	00759487	a/r	Gear, Output 14 Tooth (540 RPM)
	00759488	1	Gear, Output 17 Tooth (1000 RPM)
34*	00565000	a/r	Plug, Oil Level, Sq Head (Tapered Thread)
	00762517	a/r	Plug, Oil Level, Allen Head (Straight Thread w/ Sealing Washer)
38	00769321	2	Seal Washer, (Use Only w/ 00762517 or 00762114 Plugs)

NOTE: * There are two different type Plugs, To ID which check Threads & Head Type, Sealing washer or not, Also on type with sealing wwasher there will be a circle machined around hole to make a flat surface for washer to seal. Tapered Threaded Plugs will Not have this machined area.

Gearbox

P/N 00760403B, 00750506B & 00750507B

New Style May 96 & Up

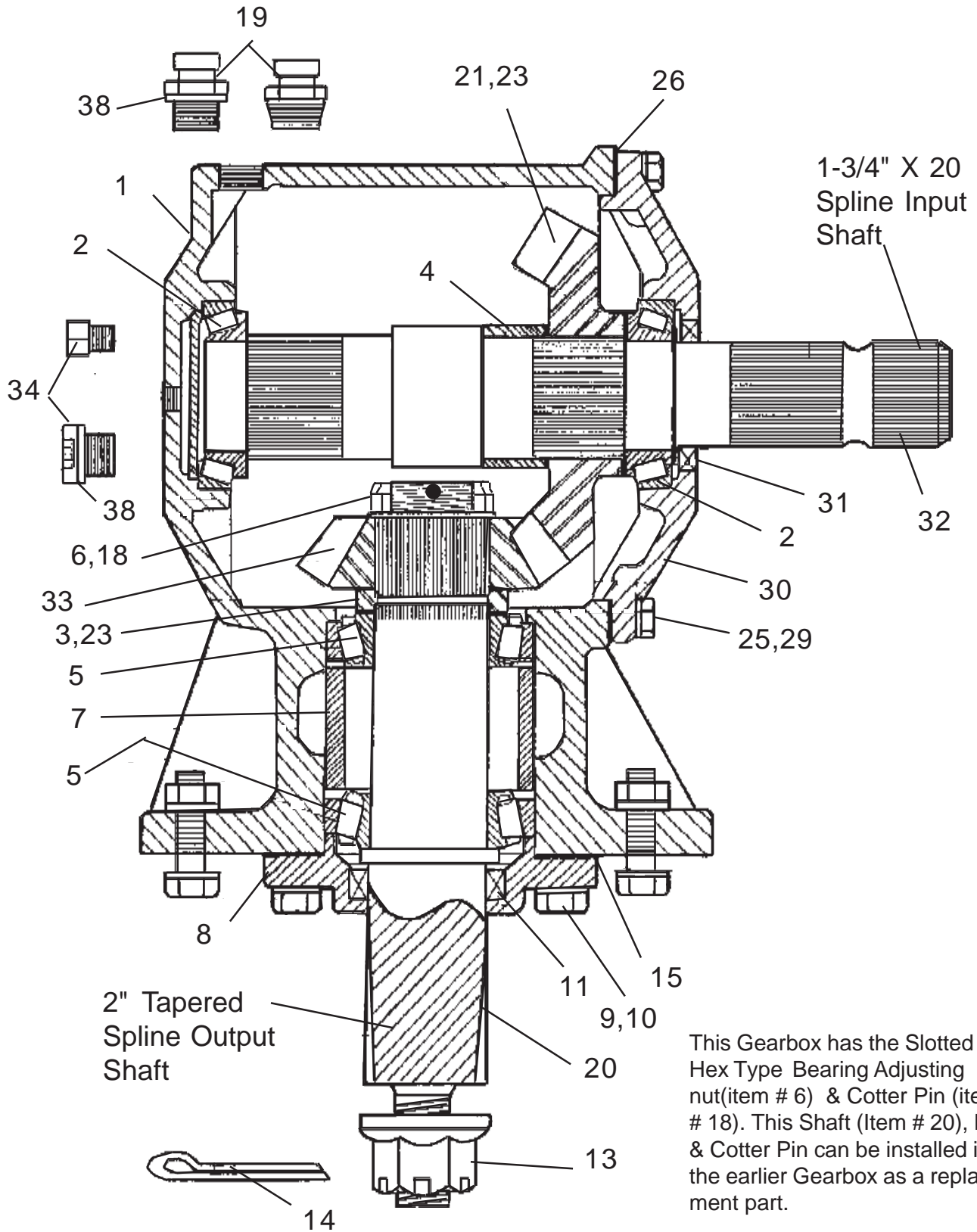

This Gearbox has the Slotted Hex Type Bearing Adjusting nut(item # 6) & Cotter Pin (item # 18). This Shaft (Item # 20), Nut & Cotter Pin can be installed in the earlier Gearbox as a replacement part.

Gearbox

P/N 00760403B, 00750506B & 00750507B

New Style May 96 & Up

Item	Part No.	Qty	Description
	00760403B	--	Gearbox Asy, 540 RPM (input gear mount in Front) As Shown
	00750506B	--	Gearbox Asy, 1000 RPM (input Gear Mount in front)As Shown
	00750507B	--	Gearbox Asy, 540 RPM (input Gear Mount in Back) Not Shown
1	00758661	1	Housing-Gearbox
2	00755615	2	Bearing Cup & Cone, Input
3	00759977	1	Gear Spacer, Output
4	00758657	1	Gear Spacer, Input
5	00769938	2	Bear Cup & Cone, Output
6	00759970	1	Bearing Adjusting Nut, Output
7	00760889	1	Bearing Spacer, Output
8	00758663	1	Bearing Cap, Output
9	00758672	4	Lockwasher
10	00758673	4	Bolt
11	00758674	1	Seal, Output Shaft
13	00758692	1	Nut, Blade Carrier Retaining
14	00606000	1	Cotter Pin
15	00758676	a/r	Gasket, Output Cap (.004) Approx 2 Ea.
	00758677	a/r	Gasket, Output Cap (.010) Approx 1 Ea.
18	00749495	1	Cotter Pin, Use w/ Brg Adjusting Nut Item # 6
19*	00758654	a/r	Pressure Relief Plug, (Tapered Threads)
	00762114	a/r	Pressure Relief Plug, (Straight Threads w/ Sealing Washer)
20	00760892	1	Output Shaft (Use Slotted Nut & Cotter Pin on Top)
21	00759488	a/r	Gear, Input 17 Tooth (540 RPM Only)
	00759487	a/r	Gear, Input 14 Tooth (1000 RPM Only)
23	00758667	a/r	Shim, Output or Input Gear Adjusting (.012) Approx 2 Ea.
	00758668	a/r	Shim, Output or Input Gear Adjusting (.020) Approx 2 Ea.
25	00755954	8	Lockwasher
26	00758646	a/r	Gasket, Input Cap (.004) Approx 2 Ea.
	00758647	a/r	Gasket, Input Cap (.010) Approx 1 Ea.
29	00758659	8	Bolt
30	00758664	1	Bearing Cap, Input
31	00758653	1	Seal, Input Shaft
32	00758689	1	Shaft, Input
33	00759487	a/r	Gear, Output 14 Tooth (540 RPM)
	00759488	a/r	Gear, Output 17 Tooth (1000 RPM)
34*	00565000	a/r	Plug, Oil Level, Sq Head (Tapered Thread)
	00762517	a/r	Plug, Oil Level, Allen Head (Straight Thread w/ Sealing Washer)
38	00769321	2	Seal Washer, (Use Only w/ 00762517 or 00762114 Plugs)

NOTE: * There are two different type Plugs, To ID which check Threads & Head Type, Sealing washer or not, Also on type with sealing wwasher there will be a circle machined around hole to make a flat surface for washer to seal. Tapered Threaded Plugs will Not have this machined area.

Gearbox

P/N 00760403B, 00750506B & 00750507B

Assembly Instructions

Asy Instructions Gearbox # 00760403B & 00760507B (540 RPM)

- 1. Install Output Shaft** (Blade Shaft), Bearings, Gear in Main Housing (#00758661)
- Install Lower Bearing Cone (#00758650 Cup & Cone) on Output Shaft (#00760892) make sure Bearing cone slides all the way down against shoulder at bottom of shaft. Slide Bearing Cup (part of #00758650) down over Bearing Cone.
- Install the 1 piece Bearing Spacer (#00760889) down over Output Shaft. Put Upper Bearing Cup (#00758650 Cup & Cone) over Shaft and slide down till it sits against Bearing Spacer. Slide upper Bearing Cone (#00758650 Cup & Cone) down over Output Shaft till it is against Bearing Cup.
- Slip Shaft with Bearings and Spacer into the Bottom Side of Main Housing, Push in shaft till upper Bearing cup is bottomed out in Main Housing.
- Slide Gear Spacer (#00759977) down over Shaft and against Upper Bearing Cone, Install Shims (#00758667 and #00758668) over Shaft, Quantity of Shims will vary, try to use same amount as was taken off. install Output Gear (540 or 1000 rpm is different Gear see drawing) down over output Shaft. There ARE 2 DIFFERENT types of Bearing Adjusting Nuts used, 1st, Tabbed locking washer and Nut, If this is type used there will be Hardened Flat washer that MUST be install on top of gear, Install Tabbed Locking washer next then Nut. 2 nd type is a Slotted Hex Nut with Cotter Pin, this type WILL NOT use Hardened Flat Washer Nut will go against gear.
- Tighten Bearing Adjusting Nut above Gear till Bearings have 14" to 16" pounds of rolling Torque then Lock Nut, eather with Bendup Tabs or Cotter Pin depending which type you have.
- Install Output Seal (#00758674) into Lower Output Cap (#00758663), Coat ID of Seal with light coat of grease. Using Shims (#00758676, #00758677 and #00758678) quantity may vary according to how large space is between Cap and Main Housing. DO USE gasket sealer on shims at this time, Install Output Cap and tighten Bolts. Check Bearing Pre-load, If correct amount of Shims used it should not have changed. Check Bearing Pre-load Again. Output Shaft Should have NO end play inward or outward. and Bearing MUST be set at a rolling Torque.
- 8. Install Input Shaft** (PTO end), Bearings, Gear in Main Housing (#00758702)
- Install Gear Spacer (#00758657) Input Shaft. Install Shim (#00758667 & #00758668) on Shaft next to Gear Spacers (the quantity will vary, try to put same as taken off), Slide Input Gear (540 RPM & 1000 RPM Gear Different see drawing), till it is against against Shims, Install Front Input Shaft Bearing Cone (#00758655 Cup & Cone) on front of Input Shaft making sure it is against Shims. Install Rear Input Shaft Bearing Cone (#00758650 Cup & Cone) on rear of input Shaft making sure it is against shoulder on Shaft.
- Install Rear Input Bearing Cup (#00758650 Cup & Cone) into Rear of Main Housing. lower Input Shaft (with Gears, Spacers, Shims and Bearing Cones on it) down into Main housing from front side. Install Bearing Cup (#00758655 Cup & Cone) into Front Input Bearing Cap (#00758664), Install Input Seal (#00758653) into Front Bearing Cap, Coat ID of Seal with light coat of grease. Using Shims (#00758646, #00758647 & #00758648) on front cover set it down over input shaft, Tighten Front cover Bolts.

Gearbox

P/N 00760403B, 00750506B & 00750507B

Assembly Instructions

11. Check Bearing Pre-Load (should be 14" to 16" pounds of rolling Torque) and Gear Back Lash between Blade Shaft Gear and Input Gear (should have .017" to .019" back Lash) If it is not correct, Move Shim from one side of input gear to other to Get Correct Back Lash, It may be required to add or remove shims from Blade Shaft output Gear to raise or lower it to get correct Back lash. Once all is correct Tighten front cover bolts and recheck Gear and Bearing settings.
12. When this has been Done fill Gearbox with Oil, Before deciding Gearbox is full wait long enough for Oil to run down between Output Shaft Bearing, Then refill with Oil, install Oil Plugs and check for leaks, After running Mower 1/2 to 1 hour check Oil Level and recheck for leaks.

Gearbox P/N 00760880

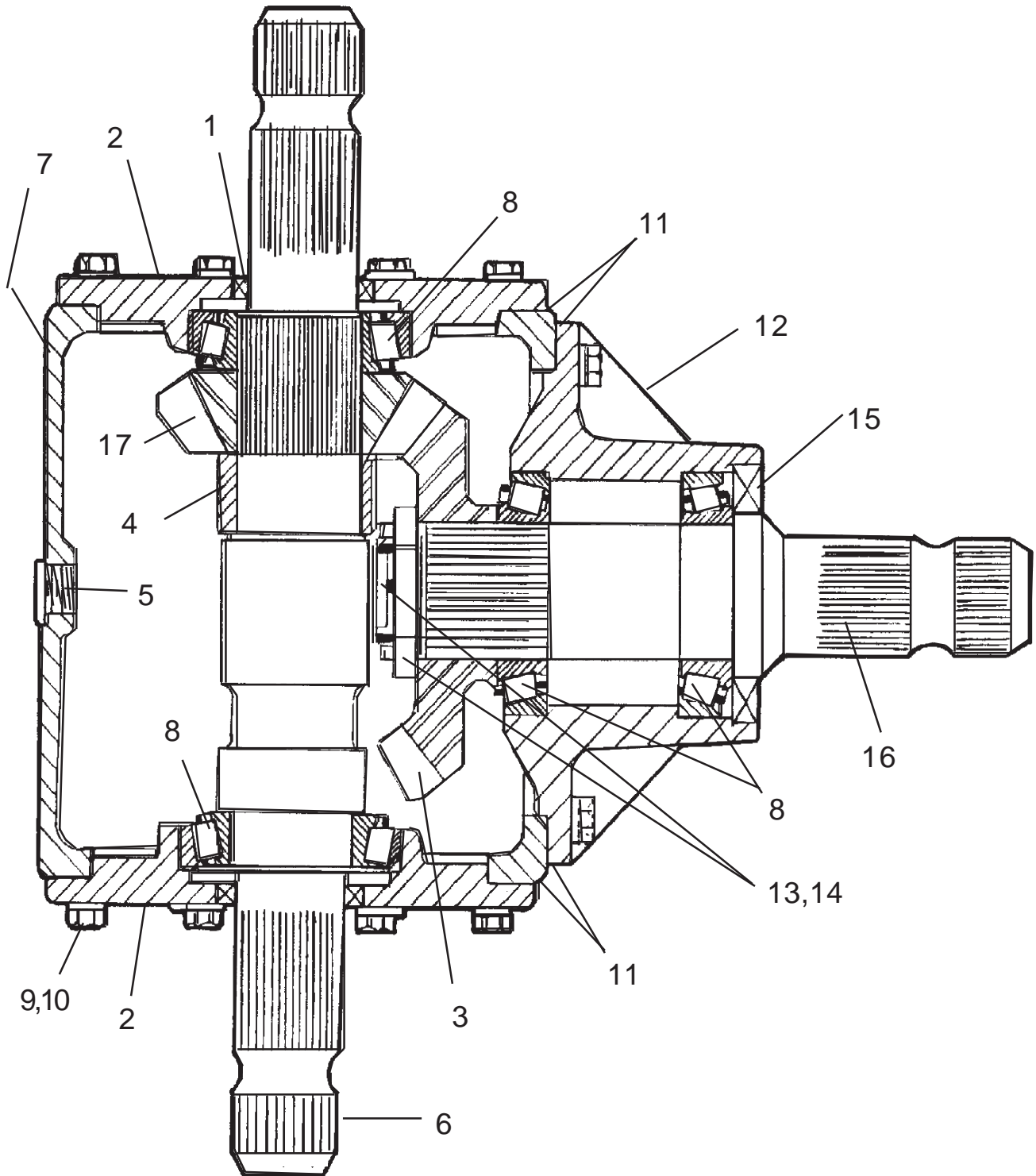

Gearbox

P/N 00760880

Item	Part No.	Qty	Description
	00760880	1	Gearbox Asy, 540 RPM
1	00758653	2	Seal, Output
2	00762516	2	Cap, Side Cover
3	00758693	1	Gear, 13 Tooth (540 RPM)
4	00758657	1	Spacer
5	00762517	2	Pipe Plug
6	00762518	1	Shaft, Output
7	00762519	1	Housing
8	00755628	4	Bearing
9	00755954	24	Lockwasher
10	00758659	24	Bolt
11	00748531	a/r	Shim Kit* (0.25, 0.30 & 0.40)
12	00762520	1	Cap, Hub Input Cover
13	00762121	1	Adjusting Nut
14	00026200	1	Cotter Pin
15	00762521	1	Seal, Input
16	00762522	1	Shaft Input
17	00758694	1	Gear, 19 Tooth (540 RPM)
18	00762114	1	Pipe Plug Vented (not illustrated)

*Shim measurements are in Metric Dimensions mm.
 Inch conversions are 0.25 mm = .009", 0.30 mm = .011" & 0.40 mm = .015"

NOTE: 540 RPM and 1000 RPM Gearbox use same parts except GEARS, To change RPM from 540 to 1000 or vice versa both Gears WILL have to be replaced, Gearbox RPM CAN NOT be changed by reversing Gears. To Check which Gearbox turn input shaft (item # 16) one complete turn, Cross Shaft (item # 6) will turn 1.46 turns for 540 RPM and 0.82 Turns for 1000 RPM for every complete turn Input Shaft is turned. The Outboard Gearboxes will turn 1 turn output for every turn input on 540 RPM or 1000 RPM as they use the same gearbox and the Gear Ratio is changed in the Divider Gearbox.

Gearbox

P/N 00760880

Assembly Instructions

Gearbox Output Shaft Installation:
Installation Part Numbers are for Gearbox #00760880 (540 RPM)

- 1. Install Cross Shaft** (Side Drive Shaft), Bearings, Gear in Main Housing (#00762519)
- Inspect the Hole in Bearing Caps for the Seal in All the openings , remove any sharp edges or burrs before installing Seal, Inspect old Seal to make sure there are no lines cut across the outer dia. of it. If there are this is good sign that burrs exist around hole. Install Bearing Cup (# 00755628 Cup & Cone) and Seal (# 00758653) into both of the 2 Side Bearing Caps (# 00762516), Coat ID of Seals with light coat of Grease.
- Using Shims from Shim Kit (# 00748531) DO NOT put gasket Sealer on Shims at this time, Install Side Bearing Cap (#00762516) to the Right Side of Main Housing (#00752519). Tighten Bolts snug.
- Install Bearing Cone (# 00755628 Cup & Cone) onto Right Side of Cross Shaft (# 00762518) Slide Gear Spacer (#00755657) on to Left Side of Shaft till it rest against the Shoulder of Shaft.
- Slide the Output Gear (# 00758694) on to Cross Shaft from Left Side till it is against the Gear Spacer. Slide the other Bearing Cone (# 00755628 Cup & Cone) on against Gear. Coat the Cross Shaft with light coat of Grease at the Seal wear area then Slide Cross Shaft with Bearings, Spacer and Gear into Main housing from the Left Side and into the Bearing Cap bolted on the right side.
- Using Shims from Shim Kit (# 00748531) DO NOT put gasket Sealer on Shims at this time, Install Side Bearing Cap (# 00762516) to the Left Side of Main Housing (# 00752519). Tighten Bolts snug.
- Check Bearing Pre-Load it should be 14 to 16 inch pounds of rolling torque, If it is not correct remove or add Shims till it is correct. and re snug Bearing Cap Bolts. DO NOT Use Gasket Sealer on Shims / Gaskets at this time.
- 8. Install Input Shaft** (PTO Shaft), Bearings, Gear in Input Hub Housing (#00762520)
- Inspect the Hole in Bearing Caps for the Seal in All the openings , remove any sharp edges or burrs before installing Seal, Inspect old Seal to make sure there are no lines cut across the outer dia. of it. If there are this is good sign that burrs exist around hole. Install Bearing Cup (# 00755628 Cup & Cone) into both ends of the Input Hub Housing, Besure to install them as shown in drawing so the bearing cones can be installed from the outside. The Input Seal (# 00762521) can be installed now into Input Housing (# 00762520).
- Slide Bearing Cone (# 00755628 Cup & Cone) onto input shaft from the Gear end, Make sure that Bearing is down against shoulder on Shaft. Put light coat of grease on Shaft at Seal wear area and around the ID of Seal then slide Input Shaft (#00762522) into Input Hub Housing.
- Slide Bearing Cone (# 00755628 Cup & Cone) onto input Shaft till it is seated in the Bearing Cup. Slide Input Gear (# 00758693) onto Input Shaft till it bottomsout against Bearing Cone.
- Screw Bearing Adjust Nut (#00762121) onto Input Shaft, Tighten Nut till Bearings have a Pre-Load of 14 to 16 inch pounds of rolling torque, Tap end of Shaft lightly with a Hammer to make sure Bearing Cones are seated in Cups and Bearing Cones are seated against Shoulder on Shaft. Recheck Bearing Preload, If it is correct install Cotter Pin (# 00026200)

Gearbox

P/N 00760880

Assembly Instructions

- 13.** Using Shims from Shim Kit (# 00748531) DO NOT put gasket Sealer on Shims at this time, Install Input Hub Housing (# 00762520) in to the front of Main Housing (# 00752519). Tighten Bolts snug.
- 14.** Check Gear Back-Lash, it should be from .017" to .019", To Set Back-Lash the Shims for the Input Hub Housing will need to be removed or more added as needed. Also the wear pattern of the Gears should be checked, This can be changed by moving Shims on the two Cross Shaft Bearing Caps from one side or the other. DO NOT remove them completely, if you remove one from one side it must be moved to the other side, this will move the cross shaft gear closer or further away from input gear and keep the correct Bearing Pre-Load.
- 15.** When all Setting are correct remoce housings and caps, use sealer on shims if desired and Re-Check all the Bolts to make sure they are tight. recheck all Settings one more time.
- 16.** Fill Gearbox with Oil, Before deciding Gearbox is full wait long enough for Oil to run down between Shafts and Bearing, Then refill with Oil, Install all Oil Fill & Vent Plugs, Check for leaks, After running Mower 1/2 to 1 hour check Oil Level and recheck for leaks.

GEARBOX

P/N 00763623

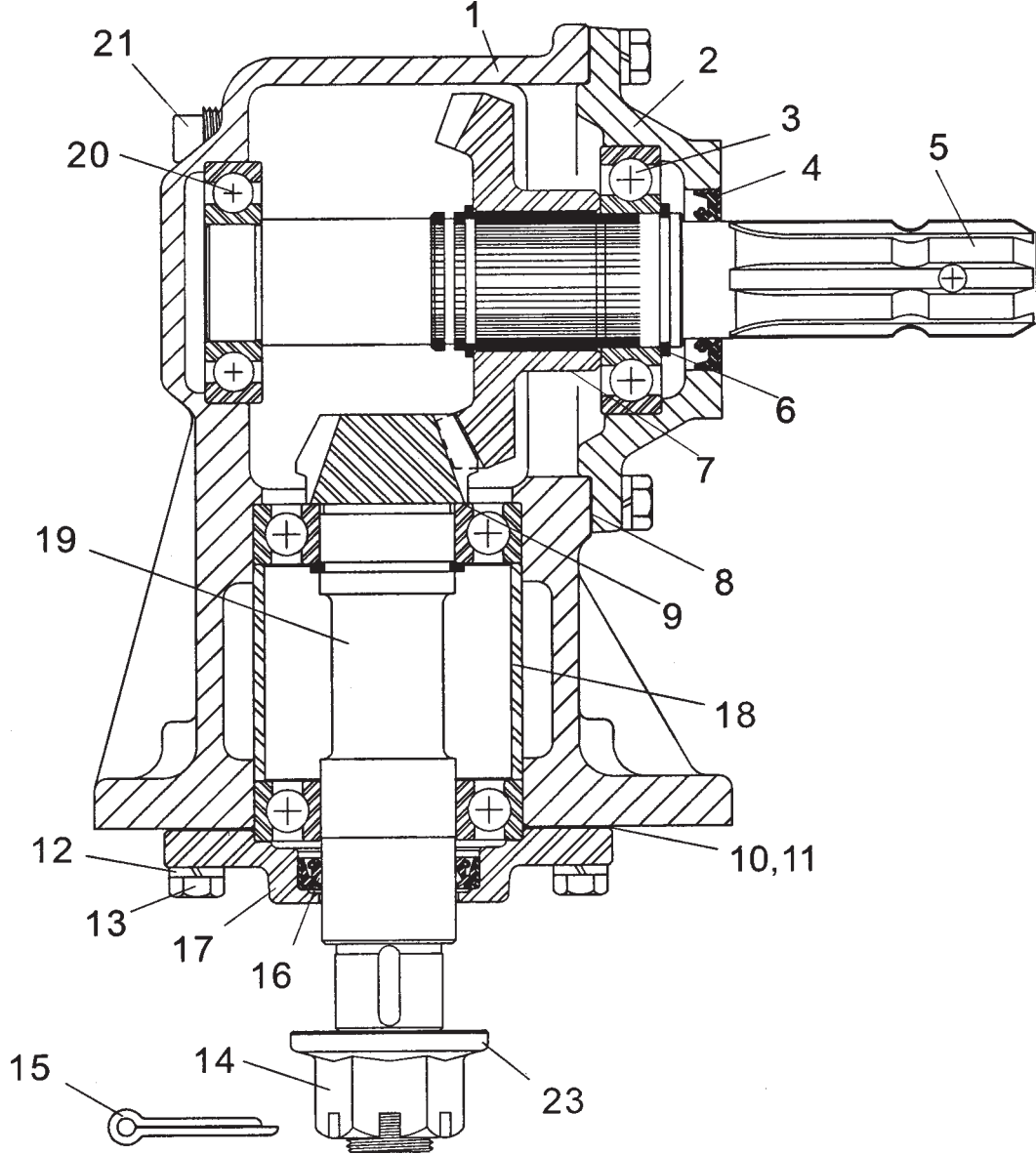

Item	Part No.	Qty	Description	Item	Part No.	Qty	Description
	00763623	-	Gearbox Asy	12	02161100	10	Lockwasher
1	00563900	1	Housing	13	00011400	10	Cap Screw
2	00764949	1	Input Cap	14	1423	1	Slotted Hex Nut
3	00563700	3	Ball Bearing	15	00606000	1	Cotter Pin
4	00564200	1	Input Seal	16	00563500	1	Output Seal
5	00764518	1	Input Shaft	17	00757683	1	Output Cap
6	00564100	3	Retaining Ring	18	00757682	1	Output Brg Spacer
7	00764516	1	Input Gear	19	00764517	1	Output Shaft/Pinion
8	00564400	a/r	Input Gasket (.30)	20	00564800	1	Ball Bearing
9	00758671	1	Shim	21	00749508	1	Oil Fill Plug
10	00760929	a/r	Ouput Gasket (.30)	22	00565000	1	Level Plug
11	00760928	a/r	Output Gasket (.13)	23	6192	1	Washer

G/B Repair Manual 07/02

GEARBOX

P/N 00763623

Assembly Instructions

- 1. Install Output Shaft/Pinion Gear** (item 19) into Main Housing (item 1) install Output Shaft before installing Input Shaft.
- 2.** Drop upper Output Shaft Bearing (item 3) onto output Shaft (item 19), install Retaining Snap Ring (item 6) on output Shaft just below upper Bearing.
- 3.** Wing Main Housing (item 1) upside down drop Output Shaft with upper Bearing on it into Housing. Slide Lower Bearing Spacer (item 18) in Housing till it seats against upper Bearing. Slide lower Output Bearing (item 3) onto Output Shaft.
- 4.** Before installing lower Seal Check seal area for scratches or burrs that will cause seal to leak. Install Lower seal (item 16) into Output Bearing Cap (item 17), Install Bearing cap using Gaskets (item 10 & 11) as required, Do Not use gasket sealer at this time on these gaskets. Use enough gasket/Gaskets to remove end play from shaft, These are Ball Bearing so there is no Bearing Pre-Load. After End Play in shaft is correct add Sealer to Gaskets.
- 5. Install Input Shaft & Gear.** Install Inner Input Shaft Bearing (item 20) into back of Main Housing (item 1), make sure bearing is seated completely into Housing.
- 6.** Install Retaining Ring (item 6) onto input Shaft (item 5), this is the one nearest the middle of the Shaft (Note there are two grooves here make sure to install it in correct one). Slide Input Gear (item 7) down onto input Shaft (item 5) till it is seated against Retaining Ring (item 6). Slide Outer Input Bearing (item 3) down over Shaft till it seat against Input gear. Install Retaining Ring (item 6) onto input shaft to hold Bearing.
- 7.** Check Input Bearing Cap (item 2) at seal area for Scratches or Burrs that could cause Seal to Leak. Install Input Seal (item 4) into Bearing Cap (item 2), Coat ID of Seal with light coat of Grease. Using Gasket/Gaskets (Item 8) Do Not use Gasket Sealer at this time. install Bearing Cap down over input shaft and tighten Bolts (item 13) Check Shaft end Play and Gear Back-Lash (.016" to .019"), if it is Correct remove Bearing Cap and install gasket Sealer if desired and reinstall checking setting again.
- 8.** Fill Gearbox with oil. DO NOT Fill with Oil above Oil Level Plug. Wait a while let Gearbox sit and have time for Oil to run down into lower Bearings and recheck Oil Level. ALWAYS recheck Oil Level after running Mower 1/2 to 1 hour. Inspect Seals for leaking after filling with Oil and after running 1/2 to 1 hour.

GEARBOX

P/N 00763623B

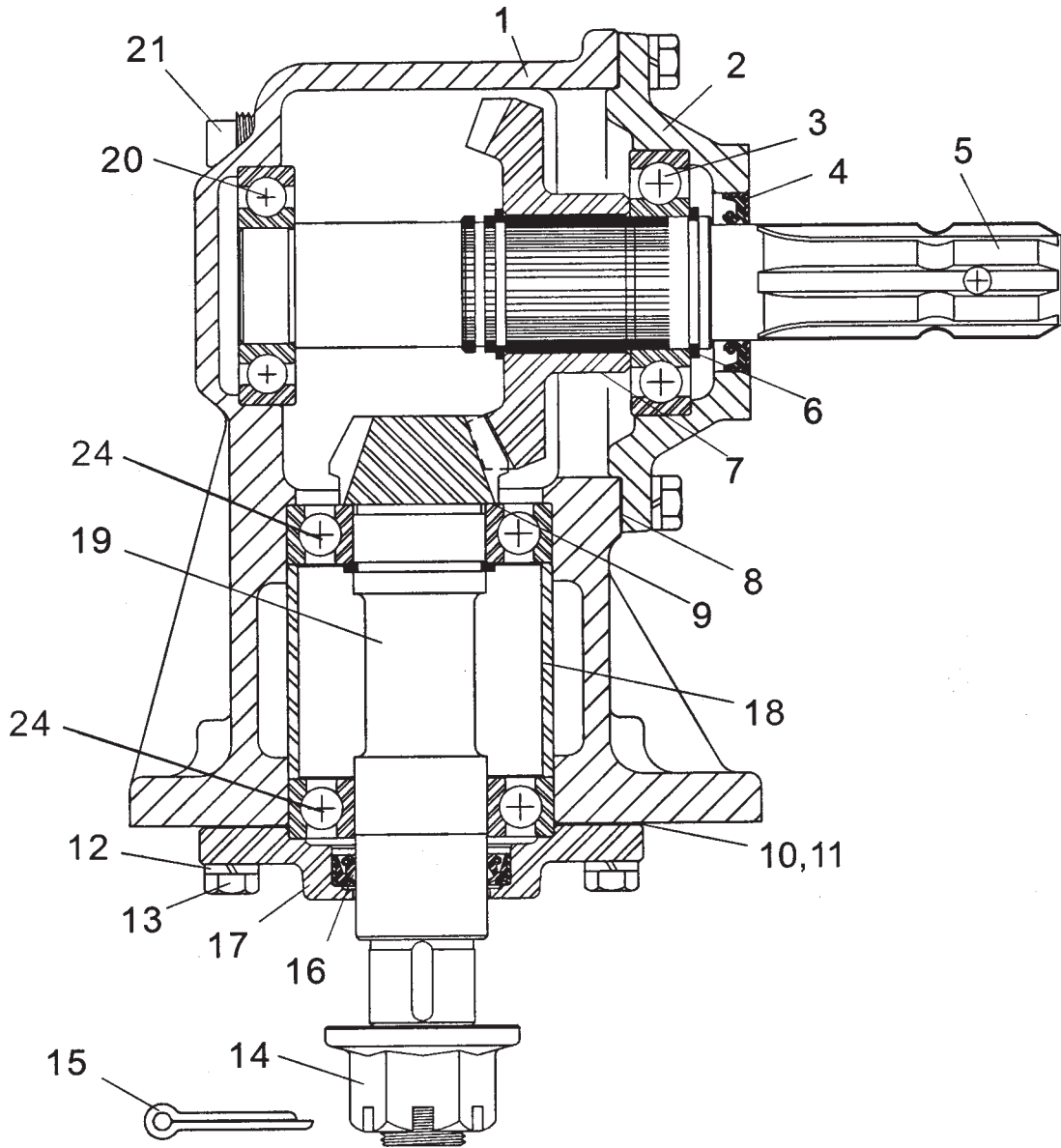

Item	Part No.	Qty	Description	Item	Part No.	Qty	Description
	00763623B	--	Gearbox Asy (540 rpm)	12	02161100	10	Lockwasher
1	00563900	1	Housing	13	00011400	10	Cap Screw
2	00764949	1	Input Cap	14	00758692	1	Slotted Flange Nut
3	00563700	3	Ball Bearing	15	00606000	1	Cotter Pin
4	00564200	1	Input Seal	16	00563500	1	Output Seal
5	00764518	1	Input Shaft	17	00757683	1	Output Cap
6	00564100	1	Retaining Ring	18	00757682	1	Output Brg Spacer
7	00764516	1	Input Gear	19	00764517	1	Output Shaft/Pinion
8	00564400	a/r	Input Gasket (.30)	20	00564800	1	Ball Bearing
9	00758671	1	Shim	21	00749508	1	Oil Fill Plug
10	00760929	a/r	Ouput Gasket (.30)	22	00565000	1	Level Plug
11	00760928	a/r	Output Gasket (.13)	23	6192	1	Washer
				24	00563700	2	Bearing, Output

G/B Repair Manual 07/02

GEARBOX

P/N 00763623B

Assembly Instructions

- 1. Install Output Shaft/Pinion Gear** (item 19) into Main Housing (item 1) install Output Shaft before installing Input Shaft.
- Drop upper Output Shaft Bearing (item 24) & Shims (item 9) onto output Shaft (item 19), install Retaining Snap Ring (item 6) on output Shaft just below upper Bearing.
- Wing Main Housing (item 1) upside down drop Output Shaft with upper Bearing on it into Housing. Slide Lower Bearing Spacer (item 18) in Housing till it seats against upper Bearing. Slide lower Output Bearing (item 24) onto Output Shaft.
- Before installing lower Seal Check seal area for scratches or burrs that will cause seal to leak. Install Lower seal (item 16) into Output Bearing Cap (item 17), Install Bearing cap using Gaskets (item 10 & 11) as required, Do Not use gasket sealer at this time on these gaskets. Use enough gasket/Gaskets to remove end play from shaft, These are Ball Bearing so there is no Bearing Pre-Load. After End Play in shaft is correct add Sealer to Gaskets.
- 5. Install Input Shaft & Gear.** Install Inner Input Shaft Bearing (item 20) into back of Main Housing (item 1), make sure bearing is seated completely into Housing.
- Install Retaining Ring (item 6) onto input Shaft (item 5), this is the one nearest the middle of the Shaft (Note there are two grooves here make sure to install it in correct one). Slide Input Gear (item 7) down onto input Shaft (item 5) till it is seated against Retaining Ring (item 6). Slide Outer Input Bearing (item 3) down over Shaft till it seat against Input gear. Install Retaining Ring (item 6) onto input shaft to hold Bearing.
- Check Input Bearing Cap (item 2) at seal area for Scratches or Burrs that could cause Seal to Leak. Install Input Seal (item 4) into Bearing Cap (item 2), Coat ID of Seal with light coat of Grease. Using Gasket/Gaskets (Item 8) Do Not use Gasket Sealer at this time. install Bearing Cap down over input shaft and tighten Bolts (item 13) Check Shaft end Play and Gear Back-Lash (.016" to .019"), if it is Correct remove Bearing Cap and install gasket Sealer if desired and reinstall checking setting again.
- Fill Gearbox with oil. DO NOT Fill with Oil above Oil Level Plug. Wait a while let Gearbox sit and have time for Oil to run down into lower Bearings and recheck Oil Level. ALWAYS recheck Oil Level after running Mower 1/2 to 1 hour. Inspect Seals for leaking after filling with Oil and after running 1/2 to 1 hour.

GEARBOX P/N 00763666

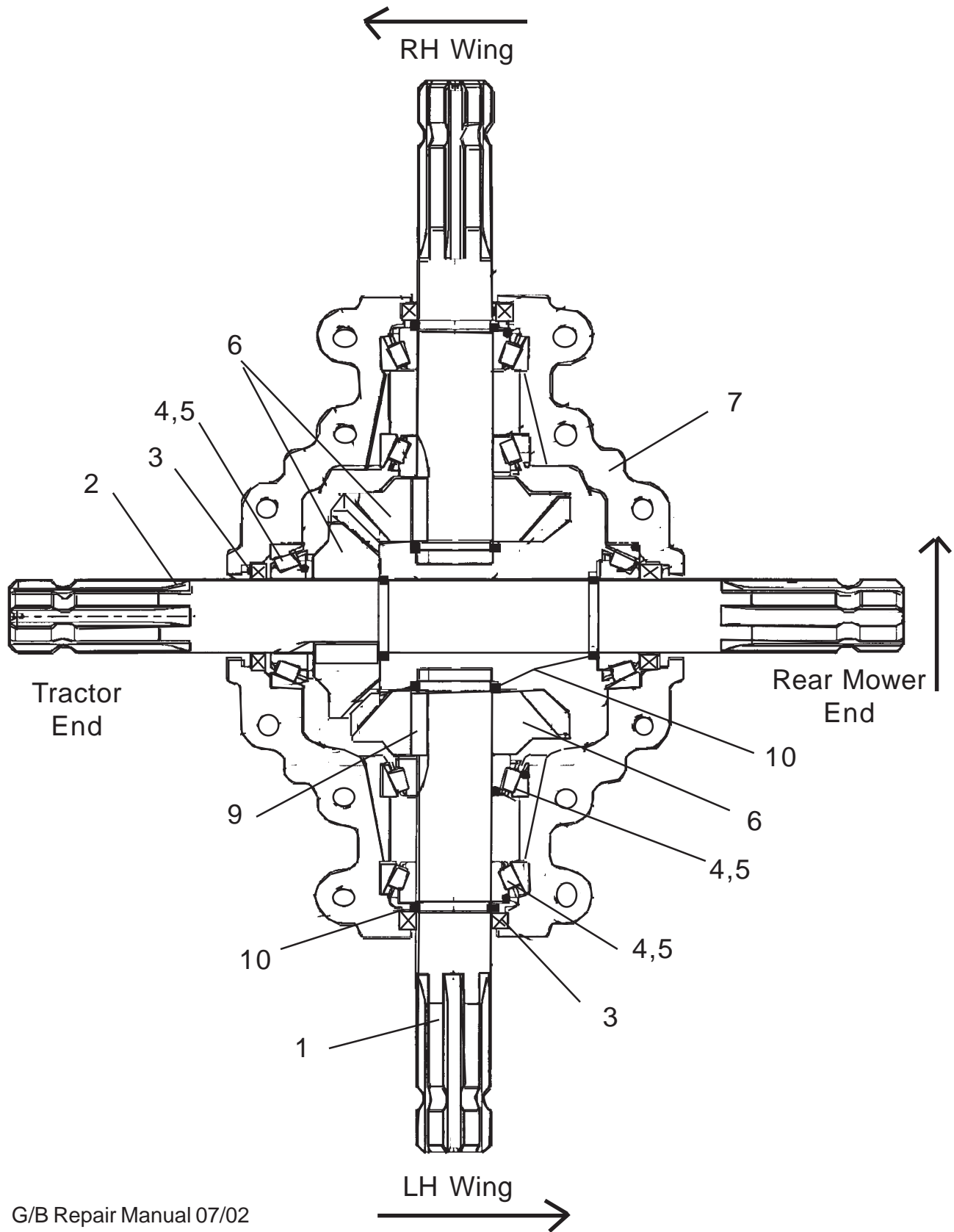

GEARBOX

P/N 00763666

Item	Part No.	Qty.	Description
1	00764462	2	Shaft, LH or RH Output
2	00764463	1	Shaft, Center Cross Input / Output
3	00764464	4	Seal
4	02957149	6	Bearing Cone
5	00016900	6	Bearing Cup
6	00764467	3	Gear
7	00764468	1	Housing Lower Half (w/ Through holes)
8	00764469	1	Housing Upper Half (w/ Tapped Holes) Not Shown
9	00764470	3	Key
10	00764471	6	Retaining Ring
11	00753630	1	Plug (Not Shown)
12	00764473	1	Bushing (Not Shown)
13	02959018	1	Relief Valve (Not Shown)
14	00764475	12	Bolt (Not Shown)

Note: RH & LH Wing Shafts use the same Components and assemble the same, All the Bearing Cones & Cups are the same. All the Retaining Snap Rings are the same. When Gearbox is bolted to Frame the Shafts should rotate in the directions of the Arrows in drawing, If it doesn't the Gearbox is mounted 180 degrees off and wing mowers will rotate backwards., Turn it over top to Bottom.

GEARBOX

P/N 00763666

Assembly Instructions

Installation Part Numbers are for Gearbox #00763666 (540 RPM)

- 1. Inspect all Components First**, Check Seal Seats, Inner & Outer Bearing Cup Seats. Inspect Housing Halves for mating surface condition, Check Threads in Housing half that is threaded.
- Prepare Housing Position for Assembly. Lay the Bottom Housing Half (item 7 the Half w/o threaded holes) on Bench in front of you, note: Look at drawing, The widest part of housing is from left to right.
- 3. Assemble Input Shaft / Cross Shaft** (item 2) into Main Housing (item 1) install Input Shaft before installing 2 Output Shafts. Notice Input shaft has 2 Retaining Snap Ring (item 10) grooves on it, Install the Snap Rings on Input Shaft now.
- On end of Input Shaft where Gear (item 6) goes there is a Keyway, Install Key (item 9) and slide Gear (item 6) down on to Input Shaft till it goes over Key and seats against Snap Ring.
- Slide Bearing Cone (item 4) down over Input Shaft till it seats against Gear, Slide Bearing Cone (item 4) down over Input Shaft on the other end till it is seated against Snap Ring. Slide a Bearing Cup (item 5) on Shaft till it is over Bearing Cones.
- Coat ID of Seals (use 2 of item 3) with a light coat of grease and slide them over ends of Cross Shaft (item 2).
- With Cross Shaft and all the Components listed above install sit it into the Housing Half (item 7) as shown in drawing.
- 8. Assemble Side Drive Shafts LH & RH**, Install Outer retaining Snap Ring (item 10) onto Side Driver Shaft (item 1). Slide Bearing Cone (item 4) onto Shaft from gear Side of Shaft till it seats against Outer Retaining Ring (item 10). Slide Bearing Cup (item 5) onto Shaft from same end
- Slide Inner bearing Cup (item 5) onto Shaft from Gear end, Install Key (item 9) into Keyway of Shaft and install Gear (item 6) over Key, Install Snap Ring (item 10) on shaft to retain Gear. Coat ID of Seal (item 3) with light coat of grease and slide it onto Shaft from outer end.
- Sit Side Drive Shaft (item 1) with Bearings, Gear, Snap Rings and Seal installed into Housing as shown in drawing. Do this for LH & RH Shaft. Make sure that these assemblies are seated down into the Bearing Cup and Seal areas completely.
- 11. Housing Halves Assemble**. Using a good Gasket Forming Material install Top Half of Housing (item 8) down onto Lower Half (item 7), Make sure that Housing goes down with out being forced. DO NOT FORCE Housing half together, If they will not slide together check the alignment of components.

GEARBOX

P/N 00763666

Assembly Instructions

12. With Halves together install the Bolts (item 12 Not Shown in Drawing) into Housing, Tighten these in a Alternating circular Pattern and in increments that will tighten the two halved together slowly and evenly Continue this till the two halves are bolted together, Inspect them to be sure
13. Install Bottom Plug (item 11 into Bottom Housing.
14. **Check Shafts for end play and Gear Back-Lash**, There is NO Adjustments on this Gearbox for Shaft End PLayer or Gear Back Lash, The Housings have been Machind to allow the proper tolerences. If Setting are not in Tolerance Assembly needs to recheck and Also Housing condition needs to be reinspected.
15. **Fill Gearbx with Oil**, If every thing is correct Fill Gearbox with oil. DO NOT Fill with Oil above Suggested Oil Level . Wait awhile and let Gearbox sit to have time for Oil to run through and intoOuter Bearings, Then recheck Oil Level. There is NO Oil Level Plug on this Gearbox. The Best way to check Oil level is with a srew Driver, Through opening for top Plug insert screw driver and use it like a Dip Stick. The Oil Level for this Gearbox is 1/2 the Height of the Gearbox Housing from Bottom to Top. ALWAYS recheck Oil Level after running Mower 1/2 to 1 hour. Inspect Seals for leaking after filling with Oil and after running 1/2 to 1 hour.

Gearbox P/N 00764053

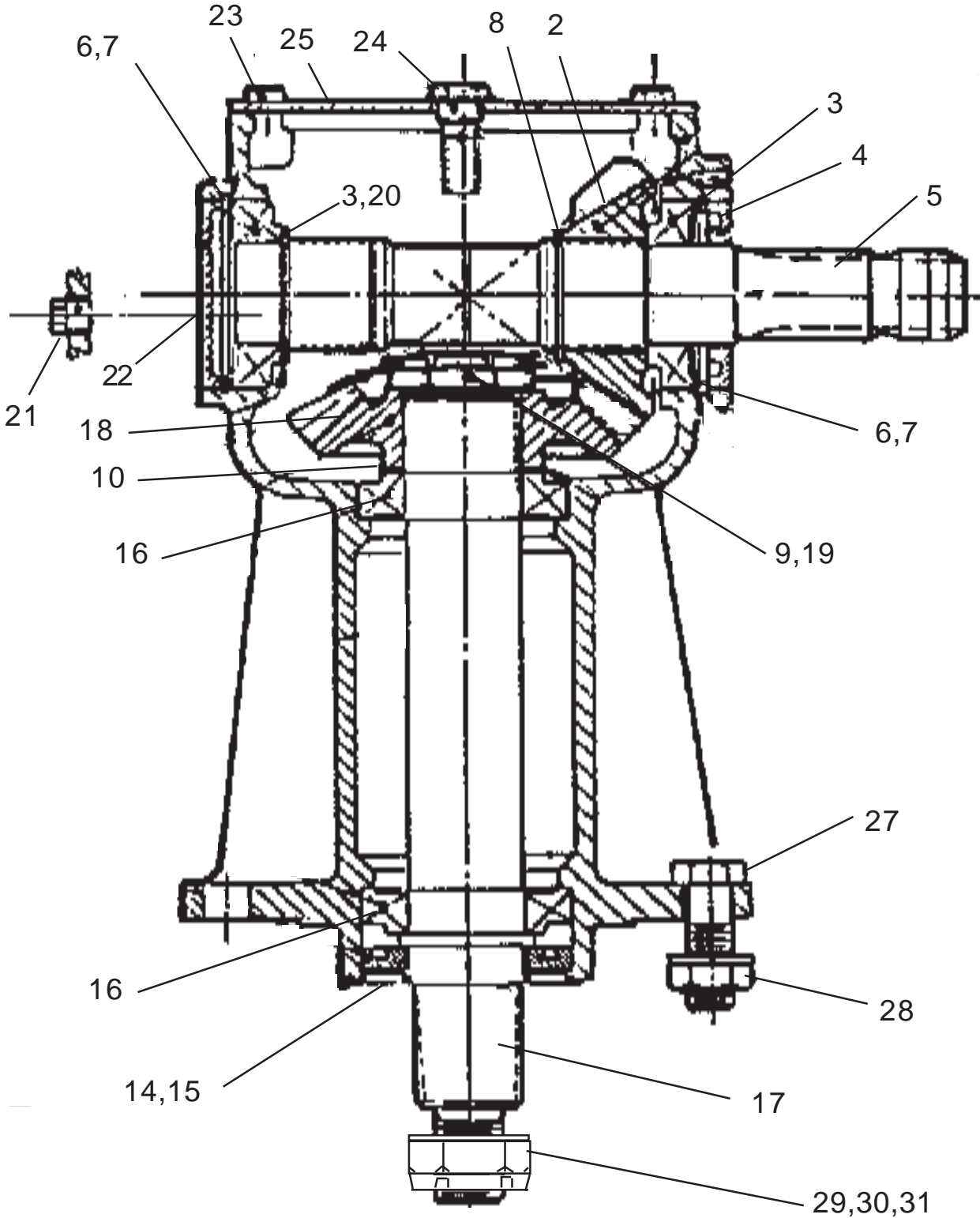

Note: Blades Turn CCW

Gearbox

P/N 00764053

Item	Part No.	Qty	Description
	00754053	--	Geabox Asy, (540 RPM)
1	00755613	1	Gearbox Housing, Main
2	00758506	1	Gear, Input 20 Tooth (540 RPM)
3	00755615	2	Bearing
4	00753238	1	Seal
5	00755617	1	Shaft, Input
6	00755618	2	Circlip, Internal
7	00755619	2	Shim
8	00755620	1	Circlip, External
9	00756943	1	Nut, Slotted
10	00755622	1	Shim
14	00755626	1	Shield, Protective
15	00755627	1	Seal
16	00755628	2	Bearing
17	00756945	1	Shaft, Output
18	00758506	1	Gear, Output 20 Tooth (540 RPM)
19	00756946	1	Cotter Pin
20	00755632	1	Shim
21	00755633	1	Plug, Oil Level Check
22	00755634	1	Seal Cap, Rear
23	00755635	4	Bolt
24	00758654	1	Plug, Vent / Oil Fill
25	00755637	1	Cover, Top
27	02959391	6	Bolt
28	00037200	6	Locknut
29	00755624	1	Nut, Blade Carrier Retaining
30	00755623	1	Washer, Blade Carrier
31	163016	1	Cotterpin, Blade Carrier

NOTE: This Gearbox has a Square Bolt on Top Cover & Input Gear is mounted in the front as shown in drawing

Gearbox

P/N 00764053

Assembly Instructions

Gearbox Output Shaft Installation:
Installation Part Numbers are for Gearbox #00764053 (540 RPM)

- 1. Install Output Shaft** (Blade Shaft), Bearings, Gear in Main Housing (#00755613)
- Install Upper Bearing Cup (#00755628 Cup & Cone) into Main Housing (#00755613) from the top, Install Lower Bearing Cup (#00755628) into Main housing from the bottom.
- Install the Lower Bearing Cone (#00755628 Cup & Cone) down over Output Shaft. Insert Output Shaft with Bearing Cone on it up through Main Housing from the bottom. Put Upper Bearing Cone (#00755628 Cup & Cone) over Output Shaft and slide down till it bottoms out in upper Bearing Cup.
- Install Shims (#00755622) down over top of Output Shaft, The number of shims required will vary, try to use the same amount as were removed. Install Output Gear (#00758506) over Output Shaft, Make sure it is seated against Shim. Insert Shim (#00755638 washer) down against gear, Screw Slotted Bearing Adjusting Nut (#00756943) onto top of Output Shaft.
- Tighten Bearing Adjusting Nut above Gear till Bearings have 14" to 16" pounds of rolling Torque then secure Bearing Adjusting Nut with Cotter Pin.
- DO NOT** Install Output Seal (#00755627) now, wait till Input Shaft has been installed, When you do install Seal Coat ID with light coat of grease. Install Seal Protector (#00755626), this drives into lower Main Housing, This Seal Protector Should always be replaced with new one after being removed. Re-Check Bearing Pre-load. Output Shaft Should have NO end play and Bearing **MUST** be set at a rolling Torque. (See 5.)
- Install Input Shaft**, Bearings and Gear into Main Housing (#00755613)
- Install External Clip (#00755620) on Input Shaft (#00755617) next to where Gear goes. Install External Clip (#00755632) on Input Shaft next to rear Bearing area. Drop Input Gear (#00758506) into Gearbox Main Housing from the top. Holding Gear in place insert Input Shaft into Main Housing from the rear through rear Bearing opening on center and left wing Gearbox, from the front on Right wing Gearbox. Slide shaft guiding it through input Gear. slide Shaft in till External Clip is against Gear.
- Install Rear Input Bearing Cone (#00755615 Cup & Cone) into Rear of Main Housing till it is against External Clip on Shaft. Install Bearing Cup (#00755615 Cup & Cone) into rear of main housing, Install Shims (#00755619) in against Bearing Cup try to use the same amount of shims as were removed. Install Internal Clip (#00755618) into Main Housing against Shims. **DO NOT** install any Seals at this time. Install Front Bearing Cone (#00755615 Cup & Cone) onto Input Shaft from the front till they are against Input Gear. Install Shims against Bearing Cup, Install Internal Clip (#00755618) into front of Main Housing against Shims. **DO NOT** install any Seals at this time.
- Check Bearing Pre-Load (should be 14" to 16" pounds of rolling Torque) and Gear Back Lash between Blade Shaft Gear and Input Gear (should have .017" to .019" back Lash) If it is not correct, Add or remove shims from Input Shaft Bearings will change Bearing Pre-load, Move Shim from one side of input Bearing to other to Get Correct Back Lash, It may be required to add or remove shims from Blade Shaft output Gear to raise or lower it to get correct Back lash. Once all is correct Install Input Seal (#00755616) and Rear Seal Cap (#00755634) then recheck Gear and Bearing settings. Now is the time to install Output seal and lower seal protector, (see step 6).

Gearbox

P/N 00764053

Assembly Instructions

11. When this has been Done fill Gearbox with Oil, Before deciding Gearbox is full wait long enough for Oil to run down between Output Shaft Bearing, Then refill with Oil, install Top Cover (using Sealer for Gasket), Oil Plugs and check for leaks, After running Mower 1/2 to 1 hour check Oil Level and recheck for leaks.

NOTE: The Following Gearboxes will assemble the same as the above with very minor differences, some componet numbers and the location of the Input gear.

Gear Box #	RPM	Input Gear
00755598.....	540 rpm.....	Front
00755566.....	540 rpm.....	Rear
00756622.....	1000 rpm.....	Front
00756624.....	1000 rpm.....	Rear
00756739.....	1000 rpm.....	Front
00756741.....	1000 rpm.....	Rear
00756744.....	1000 rpm.....	Front
00760453.....	540 rpm.....	Front

Gearbox

P/N 00769115

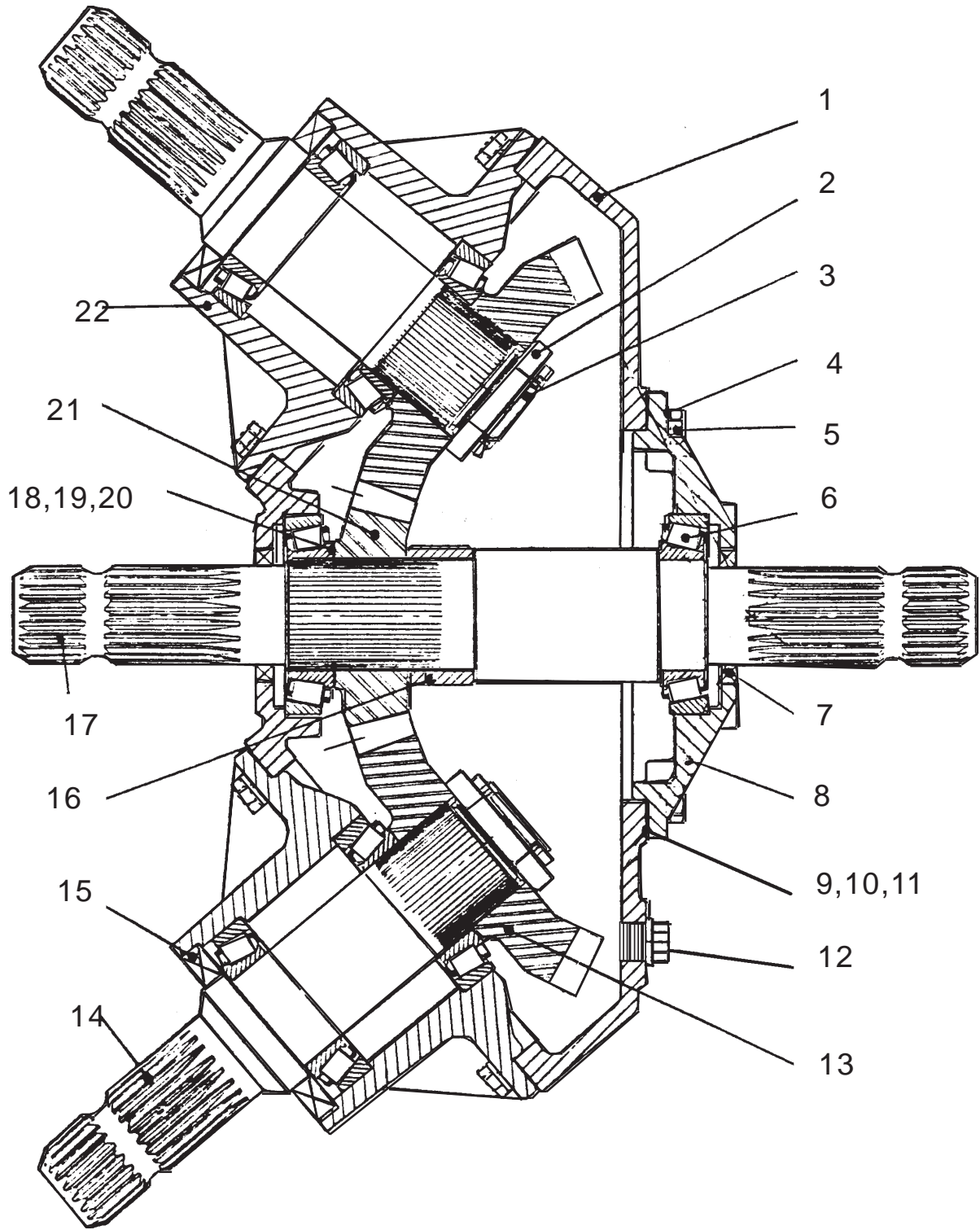

Gearbox

P/N 00769115

Item	Part No.	Qty	Description
	00769115	--	Gearbox Asy, (540 RPM)
1	00769162	1	Housing
2	00762121	2	Bearing Adj. Nut
3	00026200	2	Cotter Pin
4	00755954	24	Lockwasher
5	00758659	24	Cap Screw
6	00755628	6	Bearing
7	00758653	2	Seal
8	00762128	1	Input Cap
9	00758646	var	Gasket 0.1
10	00758647	var	Gasket 0.25
11	00758648	var	Gasket 0.5
12	00762123	1	Plug
13	00769160	2	Gear 20 Tooth (540 RPM)
14	00762522	2	Horz. Output Shaft
15	00762521	2	Seal
16	00758657	1	Spacer
17	00769163	1	Input Shaft
18	00758667	var	Shim 0 .3
19	00758666	var	Shim 0.4
20	00758668	var	Shim 0.4
21	00769161	1	Gear 23 Tooth (540 RPM)
22	00762520	2	Horz. Hub Cap
23	00762114	1	Pipe Plug Vented (not shown)
24*	00010300	4	Lockwasher (Not Shown)
25*	02675800	4	Bolt (Not Shown)

* These Bolts mount Gearbox to Deck and are located from under side of deck only, See Threaded Holes in bottom of Gearbox Housing.

Gearbox

P/N 00769115

Assembly Instructions

Assembly Instructions Gearbox
00769115 (540 rpm) and #00769116 (1000 rpm)

1. **Install Input Shaft** (Center Shaft), Bearings, Gear in Main Housing (#00758644) install Input shaft before Output Shafts to Wings
2. Install Bearing Cup (#00758655 Cup & Cone) in Main Housing and Bearing Cup (#00758655 Cup & Cone) in front Bearing Carrier Cap (#00758664), Drive Cups in till they bottom out, Check this before continuing. Then Lay Bearing Carrier Cap aside for now.
3. Install Gear Spacer (#00758657) onto Input Shaft, Slide Gear (#00758656 (23 tooth) 540 rpm or #00758670 (20 tooth) 1000 rpm)) onto Input Shaft making sure gear is against Gear Spacer, If Gear is put on backward the assemblies for Wing Output won't fit. Next install Inner Bearing Cone (#00758655 Cup & Cone) and outer Bearing Cone (#00758655 Cup & Cone) on to Shaft making sure inner bearing is bottomed out against gear and outer Bearing Cone is against shoulder on Input Shaft.
4. Install Seal (#00758653) into Bearing Carrier Cap and Seal (#00758653) into rear of Main Housing. Coat ID of Seals with light coat of Grease, using Shims (DO NOT put Gasket Sealer on Shims at this time) Tighten down Bearing Carrier Cap and check Bearing Pre-Load, It should be 14 to 16 inch pounds of rolling torque, Shaft should not have any end play in or out. If less Pre-Load is needed remove Shims if more is needed add shims. If Bearing preload is right, remove Bearing Carrier Cap and coat shims with Sealer and reinstall, Tighten Bolts and Recheck Bearing Preload.
5. **Install Output Shaft Assy**, Bearings, Gear (Output) in Horizontal Hub Housing (#00762520) Always install Center Input Shaft in Main Housing first, see step 1.
6. Install Outer Bearing Cup (#00755628 Cup & Cone) and Inner Bearing Cup (#00755828 Cup & Cone) into Horizontal Hub Housing (#00762520), (inner cup near gear and one outer cup near seal), They are the same and can be installed inner or outer Cup, Install cups in Housing till they bottom out against shoulders in Housing.
7. Install Outer Bearing Cone (#00755628 Cup & Cone) onto Output Shaft (# 00762522), Make sure Bearing is seated down against Shoulder on shaft. Slode Shaft with Bearing into Housing from Outside. Install Inner Bearing Cone (#00755628 Cup & Cone) over Shaft from Gear Side, Make sure Bearing Cone is seated into Cup. Install Gear (#00769160 (20 tooth) 540 rpm or #00769159 (26 tooth) 1000 rpm).
8. Install Bearing Adjusting Nut (#00762121) onto Output Shaft (#00762522) this holds gear on Shaft and adjust Bearing Preload. Screw Nut onto Output Shaft till it touches Gear. Continue to tighten Bearing Adjusting Nut till Bearings have 14" to 16" pounds of rolling torque. Tap Shaft with a Hammer and recheck Bearing Pre-Load, If it is correct insert Cotter Pin (#00026200) through Adjusting Nut and Shaft, Bend bend Cotter Pin over so it can not come out, this will prevent Nut from turning and loosening up.

Gearbox

P/N 00769115

Assembly Instructions

9. Install Seal (#00762521) into Horizontal Housing (#00758652), coat ID of Seal with light coat of grease and Seal into Horizontal Hub Housing.
10. To Install Output Shaft Housing Assemblies into Main Housing. (DO NOT USE any Gasket sealer at this time) Put Shims and Gasket on Output Housing Assembly and insert it into Main Housing, These shim are used to set Backlash on Gears. Backlash is changed by adding or removing Shims. Tighten Bolts and check Gear Backlash, It should be .017" to .019". When Gear Backlash is correct, Remove Bolts and put Gasket sealer on Gaskets, reinstall Bolts and Lockwashers and tighten down. Recheck Gear Back Lash.
11. After both Horizontal Hub assemblies have been installed, Install To fill Gearbox full of Oil. Fill till Oil runs out of oil level plug in side of gearbox housing. Insert Plugs, oil level plug on side and Vent plug on top. ALWAYS wait enough time for Oil to run inbtween Inner and Out Bearings on Out Put Shaft Assemblies before dicideing Oil Level is Full. After runing mower for 30 minutes to an hour always recheck oil level.

Gearbox P/N 00769116

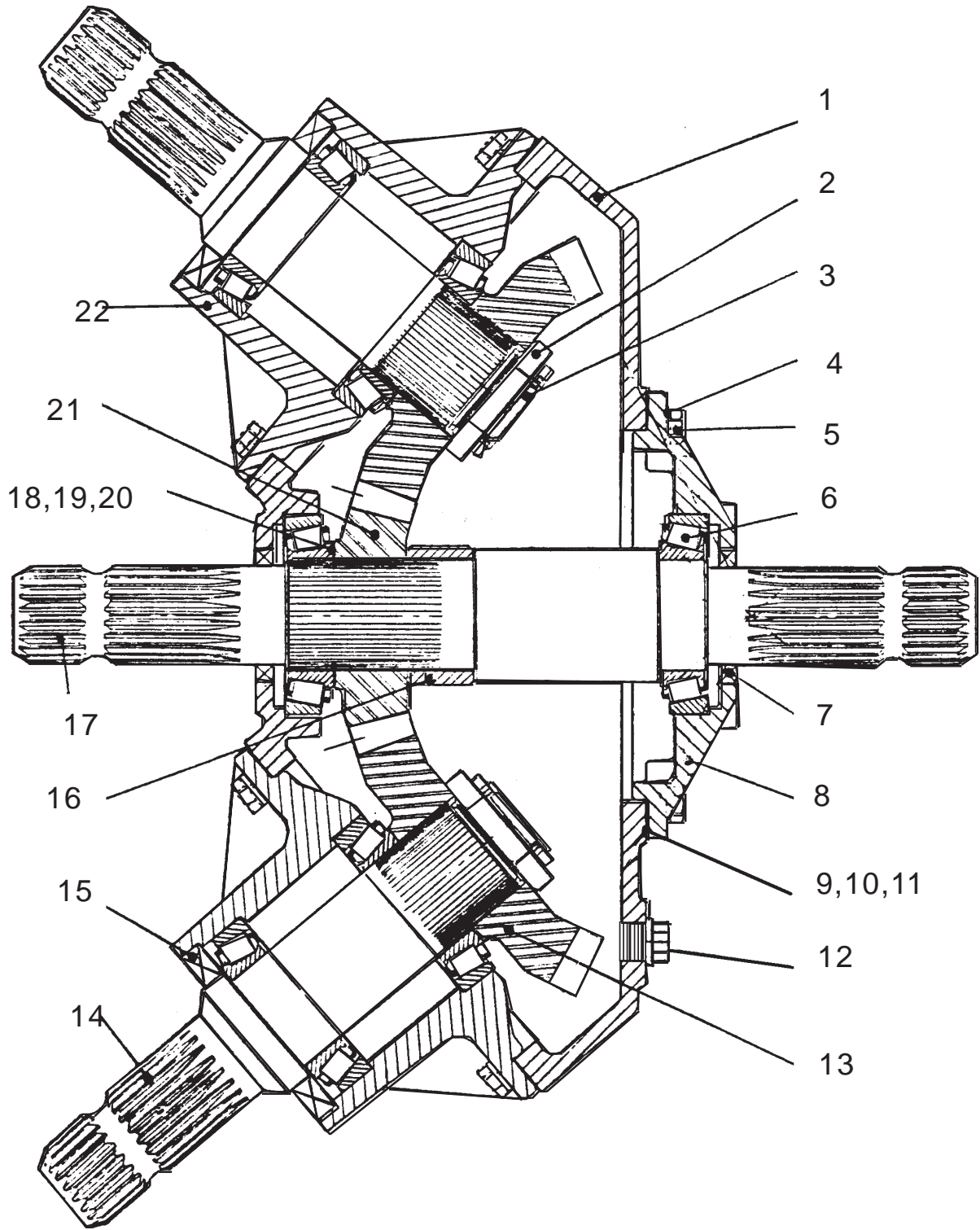

Gearbox

P/N 00769116

Item	Part No.	Qty	Description
	00769116	--	Gearbox Asy, (1000 RPM)
1	00769162	1	Housing
2	00762121	2	Bearing Adj. Nut
3	00026200	2	Cotter Pin
4	00755954	24	Lockwasher
5	00758659	24	Cap Screw
6	00755628	6	Bearing
7	00758653	2	Seal
8	00762128	1	Input Cap
9	00758646	var	Gasket 0.1
10	00758647	var	Gasket 0.25
11	00758648	var	Gasket 0.5
12	00762123	1	Plug
13	00769159	2	Gear 26 Tooth (1000 RPM)
14	00762522	2	Horz. Output Shaft
15	00762521	2	Seal
16	00758657	1	Spacer
17	00769163	1	Input Shaft
18	00758667	var	Shim 0 .3
19	00758666	var	Shim 0.4
20	00758668	var	Shim 0.4
21	00769158	1	Gear 20 Tooth (1000 RPM)
22	00762520	2	Horz. Hub Cap
23	00762114	1	Pipe Plug Vented (not shown)
24*	00010300	4	Lockwasher (Not Shown)
25*	02975800	4	Bolt (Not Shown)

* These Bolts mount Gearbox to Deck and are located from under side of deck only, See Threaded Holes in bottom of Gearbox Housing.

Gearbox

P/N 00769116

Assembly Instructions

Assembly Instructions Gearbox
00769115 (540 rpm) and #00769116 (1000 rpm)

1. **Install Input Shaft** (Center Shaft), Bearings, Gear in Main Housing (#00758644) install Input shaft before Output Shafts to Wings
2. Install Bearing Cup (#00758655 Cup & Cone) in Main Housing and Bearing Cup (#00758655 Cup & Cone) in front Bearing Carrier Cap (#00758664), Drive Cups in till they bottom out, Check this before continuing. Then Lay Bearing Carrier Cap aside for now.
3. Install Gear Spacer (#00758657) onto Input Shaft, Slide Gear (#00758656 (23 tooth) 540 rpm or #00758670 (20 tooth) 1000 rpm) onto Input Shaft making sure gear is against Gear Spacer, If Gear is put on backward the assemblies for Wing Output won't fit. Next install Inner Bearing Cone (#00758655 Cup & Cone) and outer Bearing Cone (#00758655 Cup & Cone) on to Shaft making sure inner bearing is bottomed out against gear and outer Bearing Cone is against shoulder on Input Shaft.
4. Install Seal (#00758653) into Bearing Carrier Cap and Seal (#00758653) into rear of Main Housing. Coat ID of Seals with light coat of Grease, using Shims (DO NOT put Gasket Sealer on Shims at this time) Tighten down Bearing Carrier Cap and check Bearing Pre-Load, It should be 14 to 16 inch pounds of rolling torque, Shaft should not have any end play in or out. If less Pre-Load is needed remove Shims if more is needed add shims. If Bearing preload is right, remove Bearing Carrier Cap and coat shims with Sealer and reinstall, Tighten Bolts and Recheck Bearing Preload.
5. **Install Output Shaft Asy**, Bearings, Output Gear (00769159) in Horizontal Hub Housing (#00762520) Always install Center Input Shaft in Main Housing first, see step 1.
6. Install Outer Bearing Cup (#00755628 Cup & Cone) and Inner Bearing Cup (#00755828 Cup & Cone) into Horizontal Hub Housing (#00762520), (inner cup near gear and one outer cup near seal), They are the same and can be installed inner or outer Cup, Install cups in Housing till they bottom out against shoulders in Housing.
7. Install Outer Bearing Cone (#00755628 Cup & Cone) onto Output Shaft (# 00762522), Make sure Bearing is seated down against Shoulder on shaft. Slode Shaft with Bearing into Housing from Outside. Install Inner Bearing Cone (#00755628 Cup & Cone) over Shaft from Gear Side, Make sure Bearing Cone is seated into Cup. Install Gear (#00769160 (20 tooth) 540 rpm or #00769159 (26 tooth) 1000 rpm).
8. Install Bearing Adjusting Nut (#00762121) onto Output Shaft (#00762522) this holds gear on Shaft and adjust Bearing Preload. Screw Nut onto Output Shaft till it touches Gear. Continue to tighten Bearing Adjusting Nut till Bearings have 14" to 16" pounds of rolling torque. Tap Shaft with a Hammer and recheck Bearing Pre-Load, If it is correct insert Cotter Pin (#00026200) through Adjusting Nut and Shaft, Bend bend Cotter Pin over so it can not come out, this will prevent Nut from turning and loosening up.

Gearbox

P/N 00769116

Assembly Instructions

9. Install Seal (#00762521) into Horizontal Housing (#00758652), coat ID of Seal with light coat of grease and Seal into Horizontal Hub Housing.
10. To Install Output Shaft Housing Assemblies into Main Housing. (DO NOT USE any Gasket sealer at this time) Put Shims and Gasket on Output Housing Assembly and insert it into Main Housing, These shim are used to set Backlash on Gears. Backlash is changed by adding or removing Shims. Tighten Bolts and check Gear Backlash, It should be .017" to .019". When Gear Backlash is correct, Remove Bolts and put Gasket sealer on Gaskets, reinstall Bolts and Lockwashers and tighten down. Recheck Gear Back Lash.
11. After both Horizontal Hub assemblies have been installed, Install To fill Gearbox full of Oil. Fill till Oil runs out of oil level plug in side of gearbox housing. Insert Plugs, oil level plug on side and Vent plug on top. ALWAYS wait enough time for Oil to run inbtween Inner and Out Bearings on Out Put Shaft Assemblies before dicideing Oil Level is Full. After runing mower for 30 minutes to an hour always recheck oil level.

Gearbox

P/N 00769912

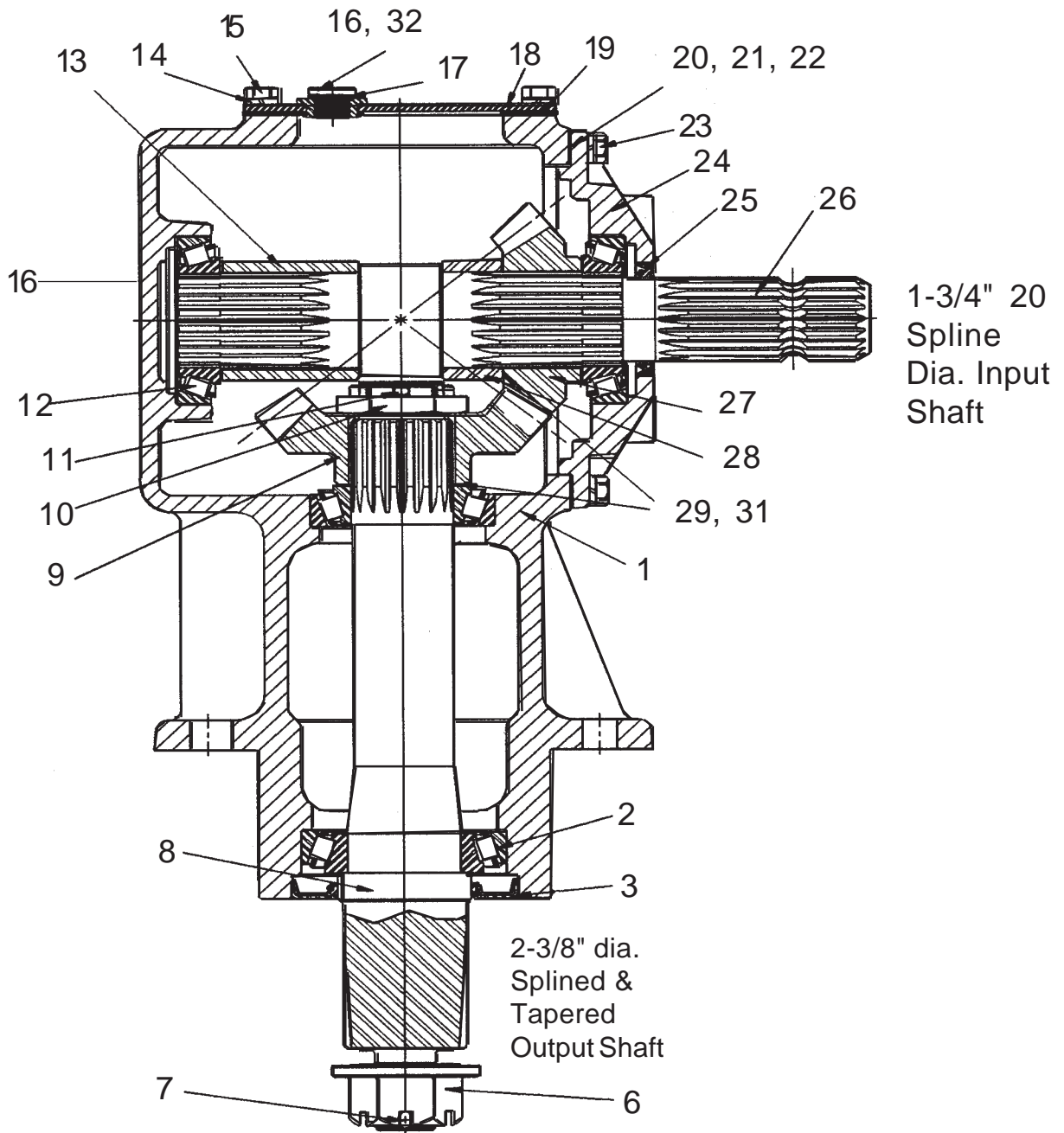

Gearbox

P/N 00769912

Item	Part No.	Qty	Description
	00769912	--	Gearbox Asy, (540 RPM)
1	00770724	1	Housing
2	00770725	1	Bearing Assembly
3	00770726	1	Oil Seal
6	00771226	1	Nut
7	01422502	1	Cotter Pin
8	00770728	1	Output Shaft
9	00770736	1	Gear , Output (13 Tooth) Center (540 RPM)
10	00770730	1	Bearing Adjusting Nut
11	00606000	1	Cotter Pin
12	00755628	3	Bearing Assembly
13	00770731	1	Shaft Spacer
14	00766083	12	Washer
15	00754338	4	Bolt
16	00762517	1	Plug, For Shipping (Install Item #32 before Operating)
16A	00762517	1	Plug, Oil level
17	00769321	3	Washer, Sealing
18	00770732	1	Inspection Cover
19	00770733	1	Inspection Cover Gasket
20	00758646	VAR	Shim Adjustment (0.10)
21	00758647	VAR	Shim Adjustment (0.25)
22	00758648	VAR	Shim Adjustment (0.50)
23	00765905	8	Bolt
24	00770734	1	Input Cap
25	00758653	1	Oil Seal
26	00770735	1	Input Shaft
27	00770729	1	Gear , Input (19 Tooth) Center (540 RPM)
28	00758657	1	Spacer
29	00758667	VAR	Shim (0.30)
31	00758668	VAR	Shim (0.50)
32	00762114	1	Pressure Plug Vent (To Be Installed before Operating)

NOTE: This Gearbox has a Round Bolt on Top Cover &
Input Gear is mounted in the front as shown in drawing

Gearbox

P/N 00769912

Assembly Instructions

Assembly Instructions and Installation Part Numbers are for Gearbox
#00769912 (540 rpm)

1. **Install Output Shaft** (Blade Shaft), Shaft, Bearings & Gear in Main Housing (1)
2. Install Upper Bearing Cup (Item 12 Cup & Cone) into Main Housing (Item 1) from the top, Install Lower Bearing Cup (item 2 Cup & Cone) into Main housing from the bottom.
3. Install the Lower Bearing Cone (item 2 Cup & Cone) down over Output Shaft. Insert Output Shaft with Bearing Cone on it up through Main Housing from the bottom. Put Upper Bearing Cone (item 12 Cup & Cone) over Output Shaft and slide down till it bottoms out in upper Bearing Cup.
4. Install Shims (item 29 & 31 a/r) as down over top of Output Shaft, The number of shims required will vary, try to use the same amount as were removed. Install Output Gear (item 9) over Output Shaft, Make sure it is seated against Shim. Screw Slotted Bearing Adjusting Nut (item 10) onto top of Output Shaft.
5. Tighten Bearing Adjusting Nut above Gear till Bearings have 14" to 16" pounds of rolling Torque then Lock Nut with Cotter Pin.
6. Install Output Seal (item 3), Coat ID of Seal with light coat of grease. Seal Protector welds to Blade Hub on this style Gearbox., Check Bearing Pre-load Again. Output Shaft Should have NO end play inward or outward. and Bearing MUST be set at a rolling Torque.
7. **Install Input Shaft**, Shaft, Bearings & Gear into Main Housing (item 1)
8. Install Inner Input Bearing Cup (item 12 Cup & Cone) into inside of Main Housing. Slide Inner Bearing Cone (item 12 Cup & Cone) into Inner Bearing Cup, Slide Sleeve (item 13 Long Sleeve) onto back side of Input Shaft (item 26), Holding Sleeve on drop Input Shaft into Housing till it is seated in inner Bearing Cone.
9. Slide Sleeve (item 28 Short Sleeve) down on Input Shaft, Install Shims (item 29 & 31 a/r) on input shaft against short sleeve. Slide Gear down on input shaft. Slide Outer Bearing Cone (item 12 Cup & Cone) down against Gear.
10. Install Outer Bearing Cup (Item 12 Cup & Cone) into front Bearing Cover (item 24), Using Shims (Item 20, 21 & 22 a/r) quantity as required on Front Bearing Cover, Tighten Bolts in front cover.
11. Check Bearing Pre-Load (should be 14" to 16" pounds of rolling Torque), Change the Bearing Pre-Load by adding or removing Shims (item 20, 21 & 22) from front Bearing Cover, When Bearing Pre-load is correct go on to Gear Back-Lash between Blade Shaft Gear and Input Gear (should have .017" to .019" back Lash) , Change Gear Back Lash by adding or removing Gear Shims (item 29 & 31) BUT it is important to make sure what ever you add or remove the same thickness must be changed on Input Bearing Cover shims to keep Bearing Pre-Load correct. in some cases it will be required to change the Shims (item 29 & 31) on Output gear to raise or lower Gear.

Gearbox

P/N 00769912

Assembly Instructions

12. Install Input Seal (item 25) if Bearing Pre-Load and Gear Back-Lash is correct. Coat ID of Seal with light coat of grease before sliding it over input shaft.
13. When this has been Done fill Gearbox with Oil, Before deciding Gearbox is full wait long enough for Oil to run down between Output Shaft Bearing, Then refill with Oil, install Top Cover (using Sealer for Gasket, Oil Plugs and check for leaks, After running Mower 1/2 to 1 hour check Oil Level and recheck for leaks.

NOTE:

The following Gearbox numbers all assemble about the same with the exception of, some part numbers and the location of the input Gear being different

Gear Box #	RPM	Input Gear
00769912.....	540 rpm.....	Front
00769915.....	540 rpm.....	Rear
00769924.....	1000 rpm.....	Front
00769918.....	1000 rpm.....	Front
00769921.....	1000 rpm.....	Rear
00769927.....	1000 rpm.....	Rear
00769930.....	1000 rpm.....	Front
00771225.....	540 rpm.....	Front

Gearbox

P/N 00769915

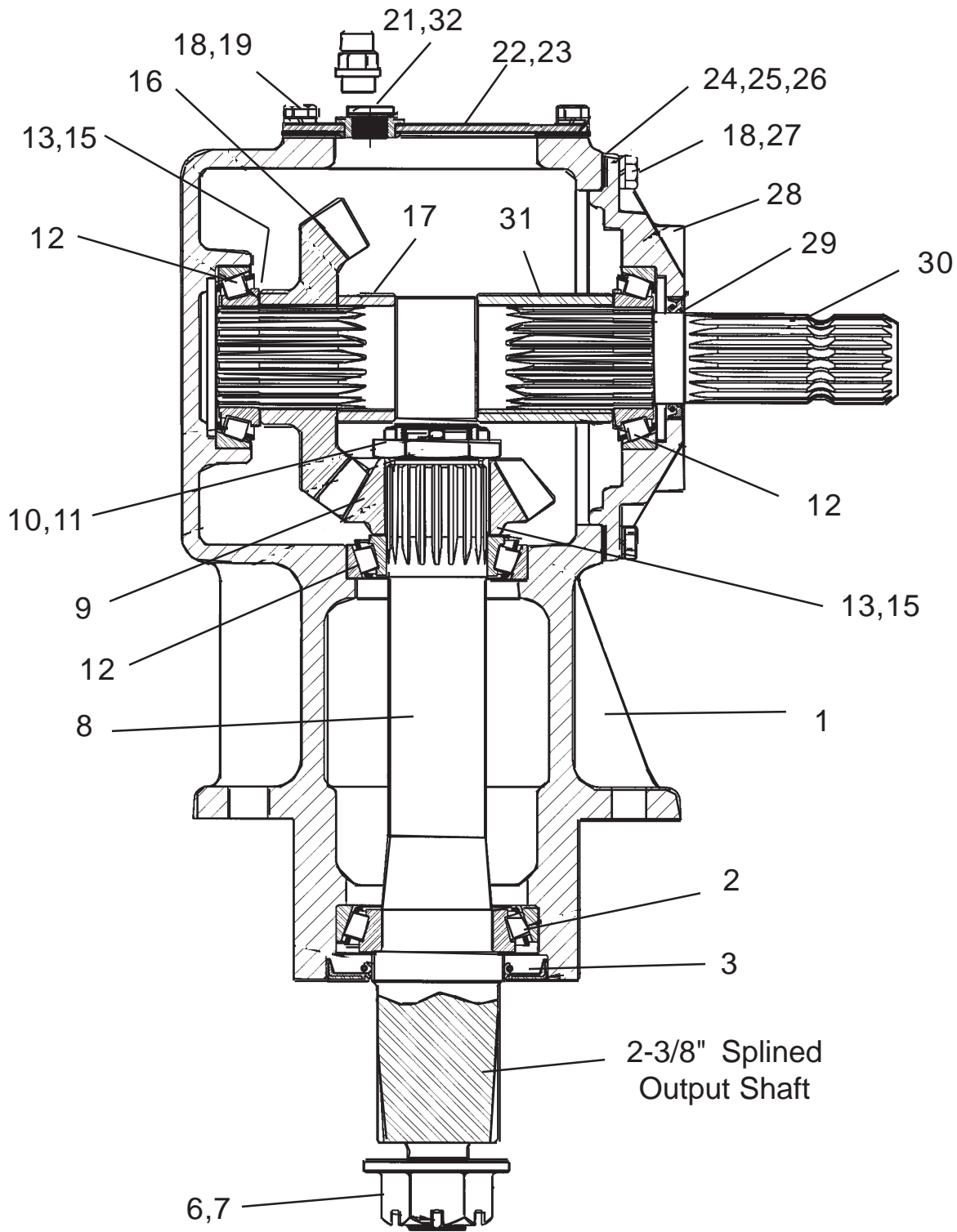

Gearbox

P/N 00769915

Item	Part No.	Qty	Description
	00769915	--	Gearbox Asy, (540 RPM)
1	00770724	1	Housing
2	00770725	1	Bearing Asy
3	00770726	1	Oil Seal
6	00771226	1	Flange Nut
7	01422502	1	Cotter Pin
8	00770728	1	Vertical Output Shaft
9	00770736	1	13 Tooth Gear (540 RPM)
10	00770730	1	Bearing Adjusting Nut
11	00606000	1	Cotter Pin
12	00755628	3	Bearing Asy
13	00758667	A/R	Shim (0.30)
15	00758668	A/R	Shim (0.50)
16	00770729	1	19 Tooth Gear (540 RPM)
17	00758657	1	Input Shaft Spacer
18	00766083	12	Lockwasher
19	00754338	4	Bolt
20	00762517	1	Plug, Oil Level Plug (Side of Housing Not Shown)
21	00769321	2	Sealing Washer (i f/item 20 & 1 f/ item 32)
22	00770732	1	Inspection Cover
23	00770733	1	Inspection Cover Gasket
24	00758646	A/R	Gasket (0.10)
25	00758647	A/R	Gasket (0.25)
26	00758648	A/R	Gasket (0.50)
27	00765905	8	Bolt
28	00770734	1	Input Cap
29	00758653	1	Oil Seal
30	00770735	1	Input Shaft
31	00770731	1	Input Shaft Spacer
32	00762517	1	Plug, For Shipping (Remove before Operating)
	00762114	1	Pressure Relief Valve (Install Before Operating)

NOTE: This Gearbox has a Round Bolt on Top Cover & Input Gear is mounted in the Back as shown in drawing

Gearbox

P/N 00769915

Assembly Instructions

Assembly Instructions and Installation Part Numbers are for Gearbox
#00769915 (540 rpm)

1. **Install Output Shaft** (Blade Shaft), Shaft, Bearings & Gear in Main Housing (1)
2. Install Upper Bearing Cup (Item 12 Cup & Cone) into Main Housing (Item 1) from the top, Install Lower Bearing Cup (item 2 Cup & Cone) into Main housing from the bottom.
3. Install the Lower Bearing Cone (item 2 Cup & Cone) down over Output Shaft. Insert Output Shaft with Bearing Cone on it up through Main Housing from the bottom. Put Upper Bearing Cone (item 12 Cup & Cone) over Out Put Shaft and slide down till it bottoms out in upper Bearing Cup.
4. Install Shims (item 13 & 15 a/r) as down over top of Output Shaft, The number of shims required will vary, try to use the same amount as were removed. Install Output Gear (item 9) over Output Shaft (item 8), Make sure it is seated against Shim. Screw Slotted Bearing Adjusting Nut (item 10) onto top of Output Shaft.
5. Tighten Bearing Adjusting Nut (item 10) above Gear till Bearings have 14" to 16" pounds of rolling Torque then Lock Nut with Cotter Pin (item 11).
6. Install Output Seal (item 3), Coat ID of Seal with light coat of grease. Seal Protector welds to Blade Hub on this style Gearbox., Check Bearing Pre-load Again. Output Shaft Should have NO end play inward or outward. and Bearing MUST be set at a rolling Torque.
7. **Install Input Shaft**, Shaft, Bearings & Gear into Main Housing (item 1)
8. With Gearbox Main Housing laying on its Back Side. Install Inner Input Bearing Cup (item 12 Cup & Cone) into inside of Main Housing. Slide Inner Bearing Cone (item 12 Cup & Cone) into Inner Bearing Cup, Lay Shims (item 13 & 15 a/r) on top of inner Bearing Cone. Lay Input Gear (item 16) in Housing against Shims and inner Bearing Cone. This can be tricky as inner Bearing Cone, Shims and Input Gear ID must line up so Input Shaft (item 30) can drop through them.
9. Slide Sleeve (item 31 Long Sleeve) down on Input Shaft, Slide Outer Bearing Cone (item 12 Cup & Cone) down against Long Sleeve (item 31)
10. Install Outer Bearing Cup (Item 12 Cup & Cone) into front Bearing Cover (item 24), Using Shims (Item 20, 21 & 22 a/r) qaunity as required on Front Bearing Cover, Tighten Bolts in front cover.
11. Check Bearing Pre-Load (should be 14" to 16" pounds of rolling Torque), Change the Bearing Pre-Load by adding or removeing Shims (item 20, 21 & 22) from front Bearing Cover, When Bearing Pre-load is correct go on to Gear Back-Lash between Blade Shaft Gear and Input Gear (should have .017" to .019" back Lash) , Change Gear Back Lash by adding or removeing Gear Shims (item 13 & 15) BUT it is important to make sure what ever you add or remove the same thickness must be changed on Input Bearing Cover shims to keep Bearing Pre-Load correct. in some cases it will be required to change the Shims (item 13 & 15) on Output gear to raise or lower Gear.

Gearbox

P/N 00769915

Assembly Instructions

12. Install Input Seal (item 25) if Bearing Pre-Load and Gear Back-Lash is correct. Coat ID of Seal with light coat of grease before sliding it over input shaft.
13. When this has been Done fill Gearbox with Oil, Before deciding Gearbox is full wait long enough for Oil to run down between Output Shaft Bearing, Then refill with Oil, install Top Cover (using Sealer for Gasket, Oil Plugs and check for leaks, After running Mower 1/2 to 1 hour check Oil Level and recheck for leaks.

NOTE:

The following Gearbox numbers all assemble about the same with the exception of, some part numbers and the location of the input Gear being different

Gear Box #	RPM	Input Gear
00769912.....	540 rpm.....	Front
00769915.....	540 rpm.....	Rear
00769924.....	1000 rpm.....	Front
00769918.....	1000 rpm.....	Front
00769921.....	1000 rpm.....	Rear
00769927.....	1000 rpm.....	Rear
00769930.....	1000 rpm.....	Front
00771225.....	540 rpm.....	Front

Gearbox P/N 00769918

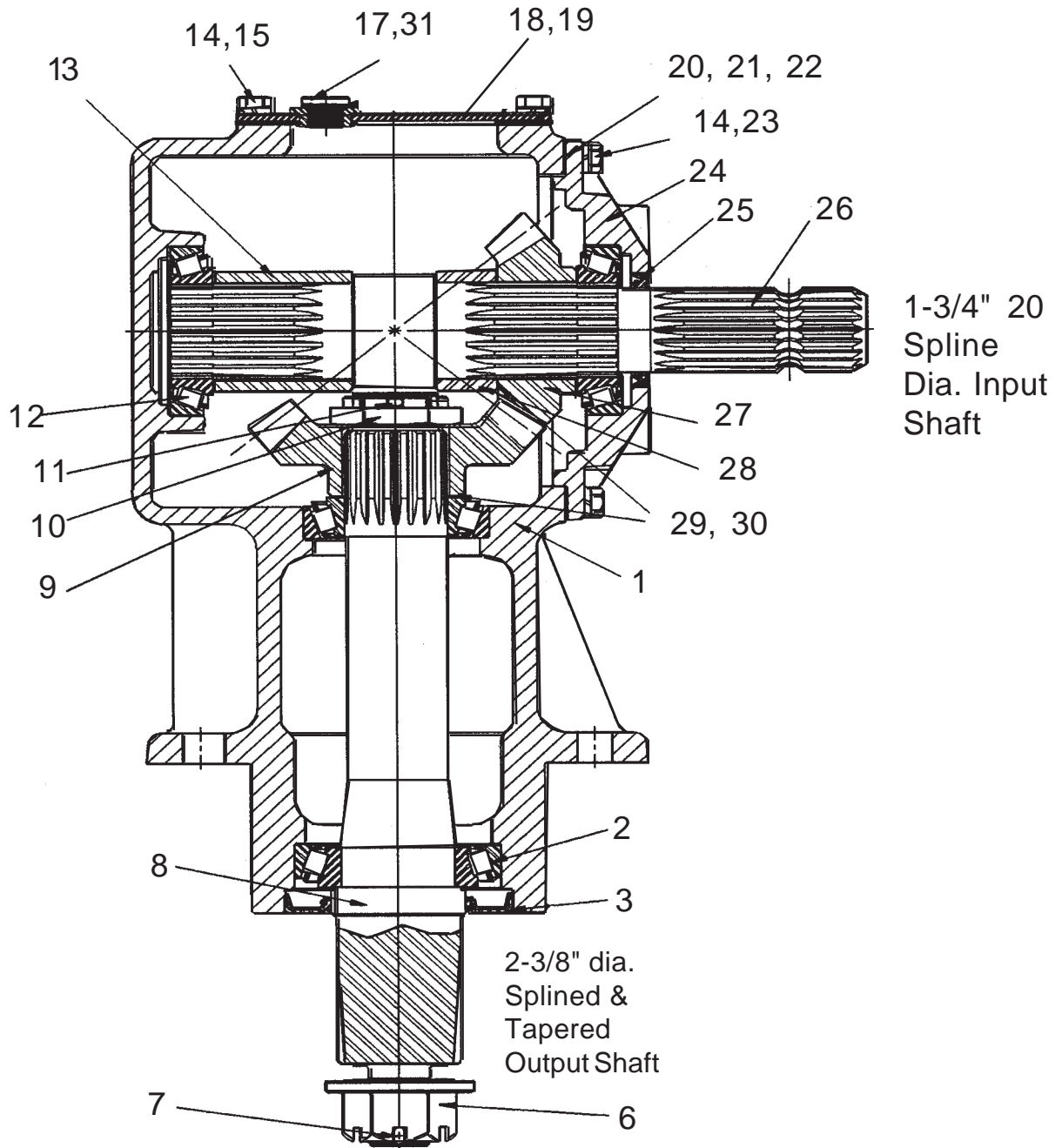

Gearbox

P/N 00769918

Item	Part No.	Qty	Description
	00769918	--	Gearbox Asy, (540 RPM)
1	00770724	1	Housing
2	00770725	1	Bearing Asy
3	00770726	1	Oil Seal
4	00770727	1	Seal Protector
6	00771226	1	Flange Nut
7	01422502	1	Cotter PIn
8	00770728	1	Vertical Output Shaft
9	00770738	1	14 Tooth Gear (540 RPM)
10	00762121	1	Bearing Adjusting Nut
11	00606000	1	Cotter PIn
12	00755628	3	Bearing Asy
13	00770731	1	Input Shaft Spacer
14	00766083	12	Lockwasher
15	00754338	4	Bolt
16	00762517	1	Plug, Oil Level Plug (Side of Housing Not Shown)
17	00769321	2	Sealing Washer
18	00770732	1	Inspection Cover
19	00770733	1	Inspection Cover Gasket
20	00758646	A/R	Gasket (0.10)
21	00758647	A/R	Gasket (0.25)
22	00758648	A/R	Gasket (0.50)
23	00765905	8	Bolt
24	00770734	1	Input Cap
25	00758653	1	Oil Seal
26	00770735	1	Input Shaft
27	00770739	1	17 Tooth Gear (540 RPM)
28	00758657	1	Input Shaft Spacer
29	00758667	A/R	Shim (0.30)
30	00758668	A/R	Shim (0.50)
31	00762517	1	Plug, For Shipping (Remove before Operating)
	00762114	1	Pressure Relief Valve (Install Before Operating)

NOTE: This Gearbox has a Round Bolt on Top Cover &
Input Gear is mounted in the front as shown in drawing

Gearbox

P/N 00769918

Assembly Instructions

Assembly Instructions and Installation Part Numbers are for Gearbox
#00769918 (540 rpm)

1. **Install Output Shaft** (Blade Shaft), Shaft, Bearings & Gear in Main Housing (1)
2. Install Upper Bearing Cup (Item 12 Cup & Cone) into Main Housing (Item 1) from the top, Install Lower Bearing Cup (item 2 Cup & Cone) into Main housing from the bottom.
3. Install the Lower Bearing Cone (item 2 Cup & Cone)) down over Output Shaft. Insert Output Shaft with Bearing Cone on it up through Main Housing from the bottom. Put Upper Bearing Cone (item 12 Cup & Cone) over Out Put Shaft and slide down till it bottoms out in upper Bearing Cup.
4. Install Shims (item 29 & 31 a/r) as down over top of Output Shaft, The number of shims required will vary, try to use the same amount as were removed. Install Output Gear (item 9) over Output Shaft, Make sure it is seated against Shim. Screw Slotted Bearing Adjusting Nut (item 10) onto top of Output Shaft.
5. Tighten Bearing Adjusting Nut above Gear till Bearings have 14" to 16" pounds of rolling Torque then Lock Nut with Cotter Pin.
6. Install Output Seal (item 3), Coat ID of Seal with light coat of grease. Seal Protector welds to Blade Hub on this style Gearbox., Check Bearing Pre-load Again. Output Shaft Should have NO end play inward or outward. and Bearing MUST be set at a rolling Torque.
7. **Install Input Shaft**, Shaft, Bearings & Gear into Main Housing (item 1)
8. Install Inner Input Bearing Cup (item 12 Cup & Cone) into inside of Main Housing. Slide Inner Bearing Cone (item 12 Cup & Cone) into Inner Bearing Cup, Slide Sleeve (item 13 Long Sleeve) onto back side of Input Shaft (item 26), Holding Sleeve on drop Input Shaft into Housing till it is seated in inner Bearing Cone.
9. Slide Sleeve (item 28 Short Sleeve) down on Input Shaft, Install Shims (item 29 & 31 a/r) on input shaft against short sleeve. Slide Gear down on input shaft. Slide Outer Bearing Cone (item 12 Cup & Cone) down against Gear.
10. Install Outer Bearing Cup (Item 12 Cup & Cone) into front Bearing Cover (item 24), Using Shims (Item 20, 21 & 22 a/r) qaunity as required on Front Bearing Cover, Tighten Bolts in front cover.
11. Check Bearing Pre-Load (should be 14" to 16" pounds of rolling Torque), Change the Bearing Pre-Load by adding or removeing Shims (item 20, 21 & 22) from front Bearing Cover, When Bearing Pre-load is correct go on to Gear Back-Lash between Blade Shaft Gear and Input Gear (should have .017" to .019" back Lash) , Change Gear Back Lash by adding or rmoveing Gear Shims (item 29 & 31) BUT it is important to make sure what ever you add or remove the same thickness must be changed on Input Bearing Cover shims to keep Bearing Pre-Load correct. in some cases it will be required to change the Shims (item 29 & 3)1 on Output gear to raise or lower Gear.

Gearbox

P/N 00769918

Assembly Instructions

12. Install Input Seal (item 25) if Bearing Pre-Load and Gear Back-Lash is correct. Coat ID of Seal with light coat of grease before sliding it over input shaft.
13. When this has been Done fill Gearbox with Oil, Before deciding Gearbox is full wait long enough for Oil to run down between Output Shaft Bearing, Then refill with Oil, install Top Cover (using Sealer for Gasket, Oil Plugs and check for leaks, After running Mower 1/2 to 1 hour check Oil Level and recheck for leaks.

NOTE:

The following Gearbox numbers all assemble about the same with the exception of, some part numbers and the location of the input Gear being different

Gear Box #	RPM	Input Gear
00769912.....	540 rpm.....	Front
00769915.....	540 rpm.....	Rear
00769924.....	1000 rpm.....	Front
00769918.....	1000 rpm.....	Front
00769921.....	1000 rpm.....	Rear
00769927.....	1000 rpm.....	Rear
00769930.....	1000 rpm.....	Front
00771225.....	540 rpm.....	Front

Gearbox

P/N 00769921

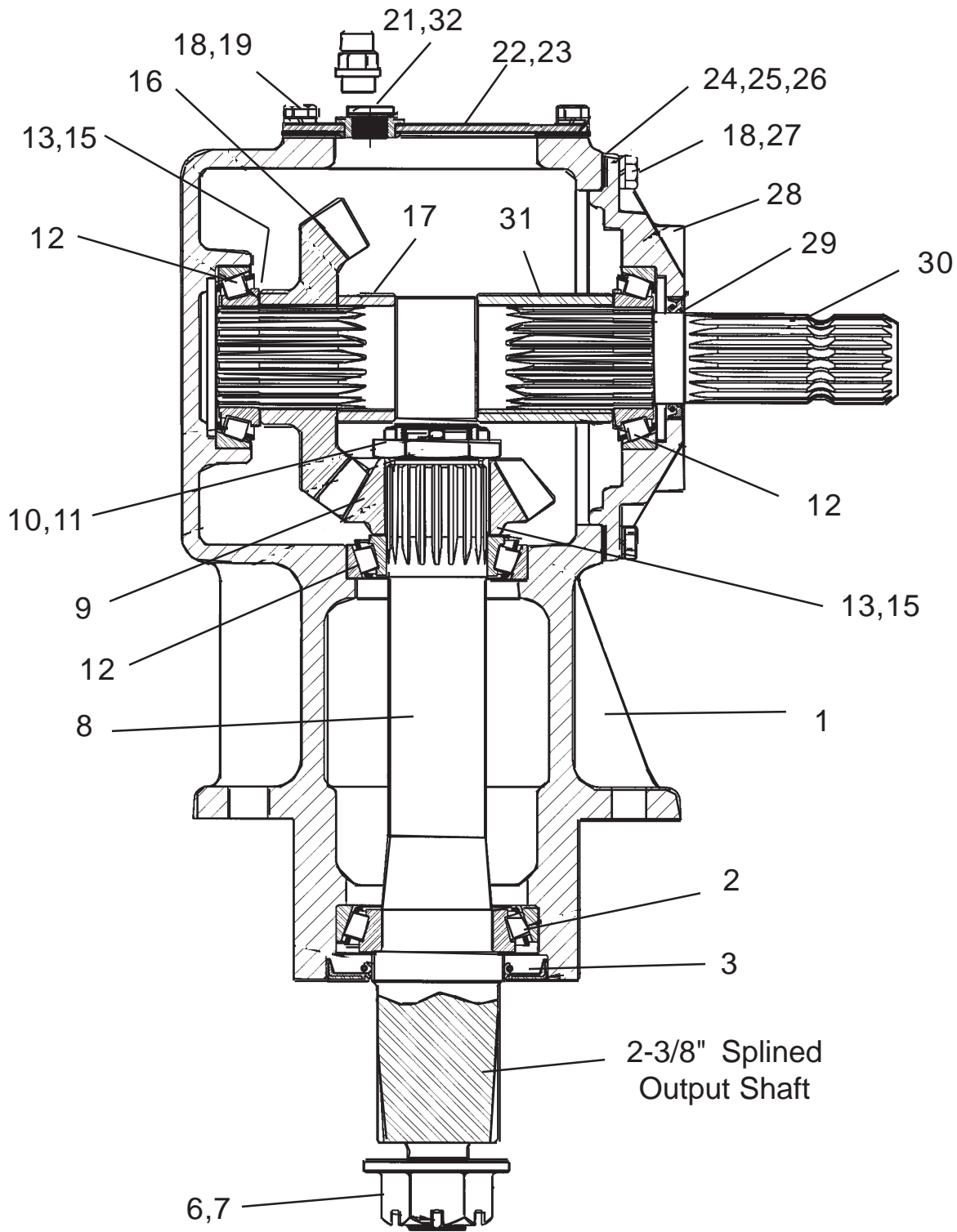

Gearbox

P/N 00769921

Item	Part No.	Qty	Description
	00769921	--	Gearbox Asy, (540 RPM)
1	00770724	1	Housing
2	00770725	1	Bearing Asy
3	00770726	1	Oil Seal
5	00771227	1	Blade Hub, Weld on & Not Shown
6	00771226	1	Flange Nut
7	01422502	1	Cotter Pin
8	00770728	1	Vertical Output Shaft
9	00770738	1	14 Tooth Gear (540 RPM)
10	00762121	1	Bearing Adjusting Nut
11	00606000	1	Cotter Pin
12	00755628	3	Bearing Asy
13	00758667	A/R	Shim (0.30)
15	00758668	A/R	Shim (0.50)
16	00770739	1	17 Tooth Gear (540 RPM)
17	00758657	1	Input Shaft Spacer
18	00766083	12	Lockwasher
19	00754338	4	Bolt
20	00762517	1	Plug, Oil Level Plug (Side of Housing Not Shown)
21	00769321	2	Sealing Washer (1 f/item 20 & 1 f/item 32)
22	00770732	1	Inspection Cover
23	00770733	1	Inspection Cover Gasket
24	00758646	A/R	Gasket (0.10)
25	00758647	A/R	Gasket (0.25)
26	00758648	A/R	Gasket (0.50)
27	00765905	8	Bolt
28	00770734	1	Input Cap
29	00758653	1	Oil Seal
30	00770735	1	Input Shaft
31	00770731	1	Input Shaft Spacer
32	00762517	1	Plug, For Shipping (Remove before Operating)
	00762114	1	Pressure Relief Valve (Install Before Operating)

NOTE: This Gearbox has a Round Bolt on Top Cover & Input Gear is mounted in the Back as shown in drawing

Gearbox

P/N 00769921

Assembly Instructions

Assembly Instructions and Installation Part Numbers are for Gearbox
#00769921 (540 rpm)

1. **Install Output Shaft** (Blade Shaft), Shaft, Bearings & Gear in Main Housing (1)
2. Install Upper Bearing Cup (Item 12 Cup & Cone) into Main Housing (Item 1) from the top, Install Lower Bearing Cup (item 2 Cup & Cone) into Main housing from the bottom.
3. Install the Lower Bearing Cone (item 2 Cup & Cone) down over Output Shaft. Insert Output Shaft with Bearing Cone on it up through Main Housing from the bottom. Put Upper Bearing Cone (item 12 Cup & Cone) over Out Put Shaft and slide down till it bottoms out in upper Bearing Cup.
4. Install Shims (item 13 & 15 a/r) as down over top of Output Shaft, The number of shims required will vary, try to use the same amount as were removed. Install Output Gear (item 9) over Output Shaft (item 8), Make sure it is seated against Shim. Screw Slotted Bearing Adjusting Nut (item 10) onto top of Output Shaft.
5. Tighten Bearing Adjusting Nut (item 10) above Gear till Bearings have 14" to 16" pounds of rolling Torque then Lock Nut with Cotter Pin (item 11).
6. Install Output Seal (item 3), Coat ID of Seal with light coat of grease. Seal Protector welds to Blade Hub on this style Gearbox., Check Bearing Pre-load Again. Output Shaft Should have NO end play inward or outward. and Bearing MUST be set at a rolling Torque.
7. **Install Input Shaft**, Shaft, Bearings & Gear into Main Housing (item 1)
8. With Gearbox Main Housing laying on its Back Side. Install Inner Input Bearing Cup (item 12 Cup & Cone) into inside of Main Housing. Slide Inner Bearing Cone (item 12 Cup & Cone) into Inner Bearing Cup, Lay Shims (item 13 & 15 a/r) on top of inner Bearing Cone. Lay Input Gear (item 16) in Housing against Shims and inner Bearing Cone. This can be tricky as inner Bearing Cone, Shims and Input Gear ID must line up so Input Shaft (item 30) can drop through them.
9. Slide Sleeve (item 31 Long Sleeve) down on Input Shaft, Slide Outer Bearing Cone (item 12 Cup & Cone) down against Long Sleeve (item 31)
10. Install Outer Bearing Cup (Item 12 Cup & Cone) into front Bearing Cover (item 24), Using Shims (Item 20, 21 & 22 a/r) qaunity as required on Front Bearing Cover, Tighten Bolts in front cover.
11. Check Bearing Pre-Load (should be 14" to 16" pounds of rolling Torque), Change the Bearing Pre-Load by adding or removeing Shims (item 20, 21 & 22) from front Bearing Cover, When Bearing Pre-load is correct go on to Gear Back-Lash between Blade Shaft Gear and Input Gear (should have .017" to .019" back Lash) , Change Gear Back Lash by adding or removeing Gear Shims (item 13 & 15) BUT it is important to make sure what ever you add or remove the same thickness must be changed on Input Bearing Cover shims to keep Bearing Pre-Load correct. in some cases it will be required to change the Shims (item 13 & 15) on Output gear to raise or lower Gear.

Gearbox

P/N 00769921

Assembly Instructions

12. Install Input Seal (item 25) if Bearing Pre-Load and Gear Back-Lash is correct. Coat ID of Seal with light coat of grease before sliding it over input shaft.
13. When this has been Done fill Gearbox with Oil, Before deciding Gearbox is full wait long enough for Oil to run down between Output Shaft Bearing, Then refill with Oil, install Top Cover (using Sealer for Gasket, Oil Plugs and check for leaks, After running Mower 1/2 to 1 hour check Oil Level and recheck for leaks.

NOTE:

The following Gearbox numbers all assemble about the same with the exception of, some part numbers and the location of the input Gear being different

Gear Box #	RPM	Input Gear
00769912.....	540 rpm.....	Front
00769915.....	540 rpm.....	Rear
00769924.....	1000 rpm.....	Front
00769918.....	1000 rpm.....	Front
00769921.....	1000 rpm.....	Rear
00769927.....	1000 rpm.....	Rear
00769930.....	1000 rpm.....	Front
00771225.....	540 rpm.....	Front

Gearbox P/N 00769924

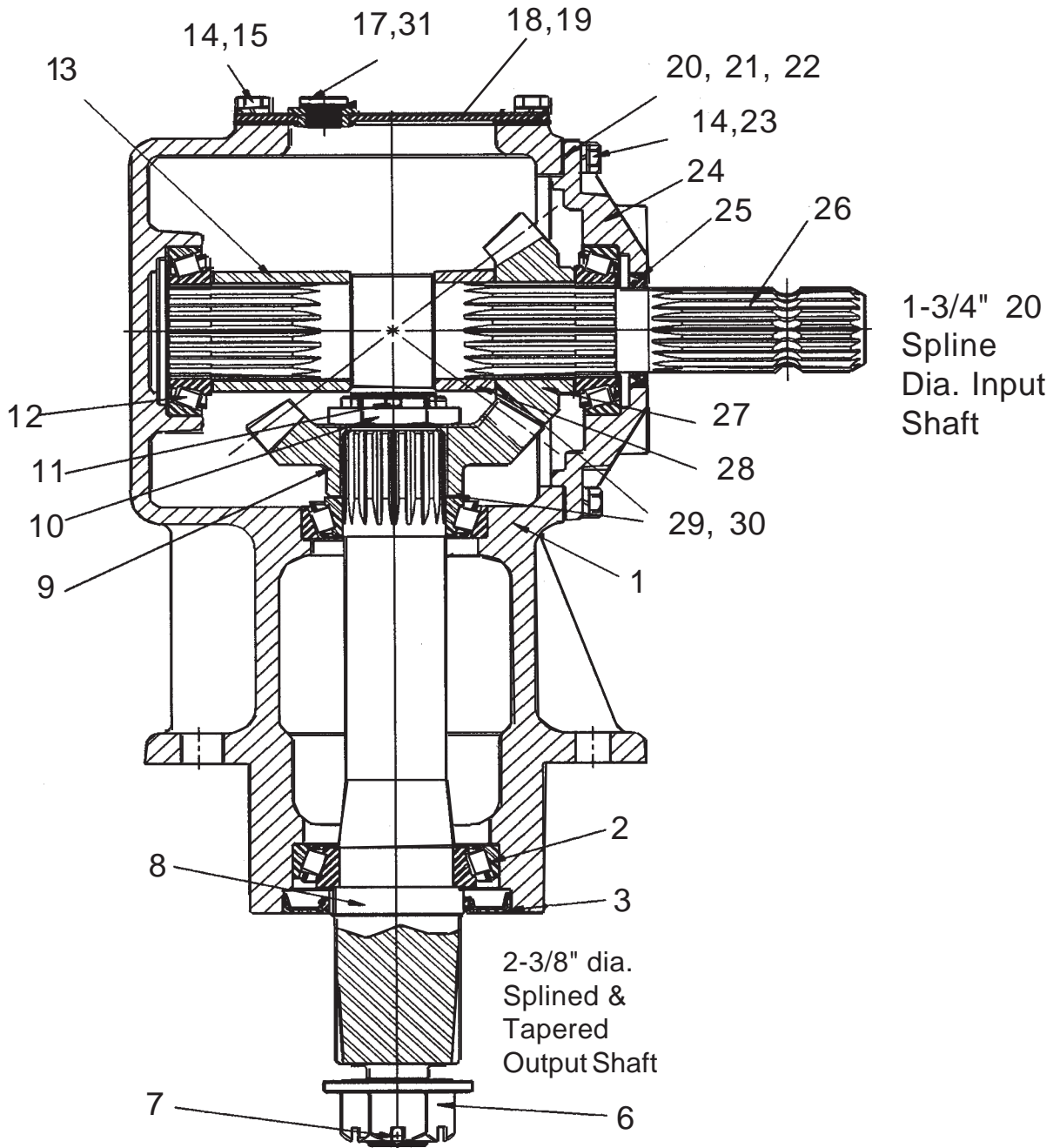

Gearbox

P/N 00769924

Item	Part No.	Qty	Description
	00769924	--	Gearbox Asy, (1000 RPM)
1	00770724	1	Housing
2	00770725	1	Bearing Asy
3	00770726	1	Oil Seal
4	00770727	1	Seal Protector
6	00771226	1	Flange Nut
7	01422502	1	Cotter PIn
8	00770728	1	Vertical Output Shaft
9	00770739	1	17 Tooth Gear (1000 RPM)
10	00762121	1	Bearing Adjusting Nut
11	00606000	1	Cotter PIn
12	00755628	3	Bearing Asy
13	00770731	1	Input Shaft Spacer
14	00766083	12	Lockwasher
15	00754338	4	Bolt
16	00762517	1	Plug, Oil Level Plug (Side of Housing Not Shown)
17	00769321	2	Sealing Washer
18	00770732	1	Inspection Cover
19	00770733	1	Inspection Cover Gasket
20	00758646	A/R	Gasket (0.10)
21	00758647	A/R	Gasket (0.25)
22	00758648	A/R	Gasket (0.50)
23	00765905	8	Bolt
24	00770734	1	Input Cap
25	00758653	1	Oil Seal
26	00770735	1	Input Shaft
27	00770738	1	14 Tooth Gear (1000 RPM)
28	00758657	1	Input Shaft Spacer
29	00758667	A/R	Shim (0.30)
30	00758668	A/R	Shim (0.50)
31	00762517	1	Plug, For Shipping (Remove before Operating)
	00762114	1	Pressure Relief Valve (Install Before Operating)

NOTE: This Gearbox has a Round Bolt on Top Cover &
Input Gear is mounted in the front as shown in drawing

Gearbox

P/N 00769924

Assembly Instructions

Assembly Instructions and Installation Part Numbers are for Gearbox
#00769924 (1000 rpm)

- 1. Install Output Shaft** (Blade Shaft), Shaft, Bearings & Gear in Main Housing (1)
- Install Upper Bearing Cup (Item 12 Cup & Cone) into Main Housing (Item 1) from the top, Install Lower Bearing Cup (item 2 Cup & Cone) into Main housing from the bottom.
- Install the Lower Bearing Cone (item 2 Cup & Cone)) down over Output Shaft. Insert Output Shaft with Bearing Cone on it up through Main Housing from the bottom. Put Upper Bearing Cone (item 12 Cup & Cone) over Out Put Shaft and slide down till it bottoms out in upper Bearing Cup.
- Install Shims (item 29 & 31 a/r) as down over top of Output Shaft, The number of shims required will vary, try to use the same amount as were removed. Install Output Gear (item 9) over Output Shaft, Make sure it is seated against Shim. Screw Slotted Bearing Adjusting Nut (item 10) onto top of Output Shaft.
- Tighten Bearing Adjusting Nut above Gear till Bearings have 14" to 16" pounds of rolling Torque then Lock Nut with Cotter Pin.
- Install Output Seal (item 3), Coat ID of Seal with light coat of grease. Seal Protector welds to Blade Hub on this style Gearbox., Check Bearing Pre-load Again. Output Shaft Should have NO end play inward or outward. and Bearing MUST be set at a rolling Torque.
- 7. Install Input Shaft**, Shaft, Bearings & Gear into Main Housing (item 1)
- Install Inner Input Bearing Cup (item 12 Cup & Cone) into inside of Main Housing. Slide Inner Bearing Cone (item 12 Cup & Cone) into Inner Bearing Cup, Slide Sleeve (item 13 Long Sleeve) onto back side of Input Shaft (item 26), Holding Sleeve on drop Input Shaft into Housing till it is seated in inner Bearing Cone.
- Slide Sleeve (item 28 Short Sleeve) down on Input Shaft, Install Shims (item 29 & 31 a/r) on input shaft against short sleeve. Slide Gear down on input shaft. Slide Outer Bearing Cone (item 12 Cup & Cone) down against Gear.
- Install Outer Bearing Cup (Item 12 Cup & Cone) into front Bearing Cover (item 24), Using Shims (Item 20, 21 & 22 a/r) qaunity as required on Front Bearing Cover, Tighten Bolts in front cover.
- Check Bearing Pre-Load (should be 14" to 16" pounds of rolling Torque), Change the Bearing Pre-Load by adding or removeing Shims (item 20, 21 & 22) from front Bearing Cover, When Bearing Pre-load is correct go on to Gear Back-Lash between Blade Shaft Gear and Input Gear (should have .017" to .019" back Lash) , Change Gear Back Lash by adding or rmoveing Gear Shims (item 29 & 31) BUT it is important to make sure what ever you add or remove the same thickness must be changed on Input Bearing Cover shims to keep Bearing Pre-Load correct. in some cases it will be required to change the Shims (item 29 & 31) on Output gear to raise or lower Gear.

Gearbox

P/N 00769924

Assembly Instructions

12. Install Input Seal (item 25) if Bearing Pre-Load and Gear Back-Lash is correct. Coat ID of Seal with light coat of grease before sliding it over input shaft.
13. When this has been Done fill Gearbox with Oil, Before deciding Gearbox is full wait long enough for Oil to run down between Output Shaft Bearing, Then refill with Oil, install Top Cover (using Sealer for Gasket, Oil Plugs and check for leaks, After running Mower 1/2 to 1 hour check Oil Level and recheck for leaks.

NOTE:

The following Gearbox numbers all assemble about the same with the exception of, some part numbers and the location of the input Gear being different

Gear Box #	RPM	Input Gear
00769912.....	540 rpm.....	Front
00769915.....	540 rpm.....	Rear
00769924.....	1000 rpm.....	Front
00769918.....	1000 rpm.....	Front
00769921.....	1000 rpm.....	Rear
00769927.....	1000 rpm.....	Rear
00769930.....	1000 rpm.....	Front
00771225.....	540 rpm.....	Front

Gearbox

P/N 00769927

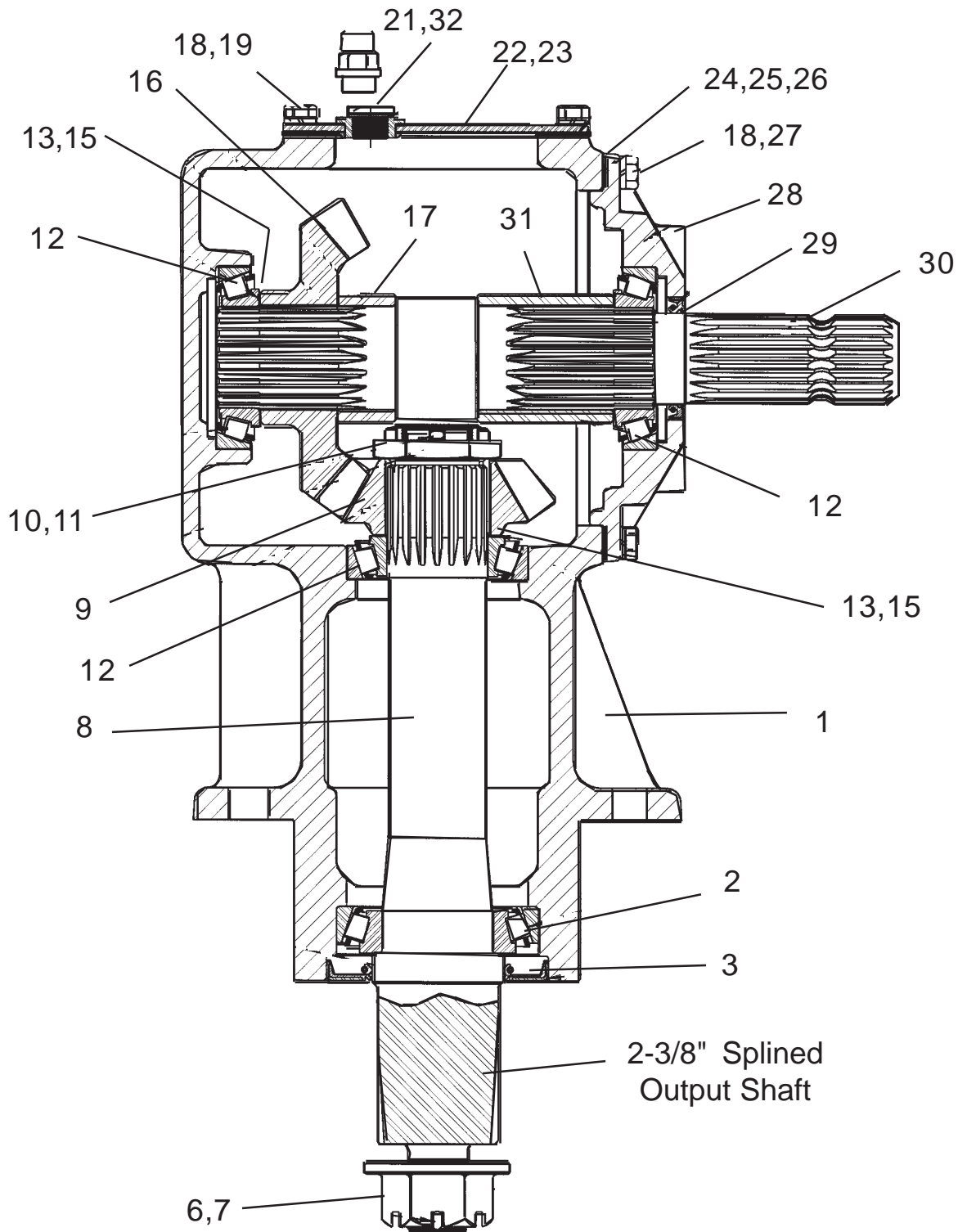

Gearbox

P/N 00769927

Item	Part No.	Qty	Description
	00769927	--	Gearbox Asy, (1000 RPM)
1	00770724	1	Housing
2	00770725	1	Bearing Asy
3	00770726	1	Oil Seal
5	00771227	1	Blade Hub, Weld on & Not Shown
6	00771226	1	Flange Nut
7	01422502	1	Cotter Pin
8	00770728	1	Vertical Output Shaft
9	00770739	1	17 Tooth Gear (1000 RPM)
10	00762121	1	Bearing Adjusting Nut
11	00606000	1	Cotter Pin
12	00755628	3	Bearing Asy
13	00758667	A/R	Shim (0.30)
15	00758668	A/R	Shim (0.50)
16	00770738	1	14 Tooth Gear (1000 RPM)
17	00758657	1	Input Shaft Spacer
18	00766083	12	Lockwasher
19	00754338	4	Bolt
20	00762517	1	Plug, Oil Level Plug (Side of Housing Not Shown)
21	00769321	2	Sealing Washer (1 f/item 20 & 1 f/ item 32)
22	00770732	1	Inspection Cover
23	00770733	1	Inspection Cover Gasket
24	00758646	A/R	Gasket (0.10)
25	00758647	A/R	Gasket (0.25)
26	00758648	A/R	Gasket (0.50)
27	00765905	8	Bolt
28	00770734	1	Input Cap
29	00758653	1	Oil Seal
30	00770735	1	Input Shaft
31	00770731	1	Input Shaft Spacer
32	00762517	1	Plug, For Shipping (Remove before Operating)
	00762114	1	Pressure Relief Valve (Install Before Operating)

NOTE: This Gearbox has a Round Bolt on Top Cover & Input Gear is mounted in the Back as shown in drawing

Gearbox

P/N 00769927

Assembly Instructions

Assembly Instructions and Installation Part Numbers are for Gearbox
#00769927 (1000 rpm)

1. **Install Output Shaft** (Blade Shaft), Shaft, Bearings & Gear in Main Housing (1)
2. Install Upper Bearing Cup (Item 12 Cup & Cone) into Main Housing (Item 1) from the top, Install Lower Bearing Cup (item 2 Cup & Cone) into Main housing from the bottom.
3. Install the Lower Bearing Cone (item 2 Cup & Cone)) down over Output Shaft. Insert Output Shaft with Bearing Cone on it up through Main Housing from the bottom. Put Upper Bearing Cone (item 12 Cup & Cone) over Out Put Shaft and slide down till it bottoms out in upper Bearing Cup.
4. Install Shims (item 13 & 15 a/r) as down over top of Output Shaft, The number of shims required will vary, try to use the same amount as were removed. Install Output Gear (item 9) over Output Shaft (item 8), Make sure it is seated against Shim. Screw Slotted Bearing Adjusting Nut (item 10) onto top of Output Shaft.
5. Tighten Bearing Adjusting Nut (item 10) above Gear till Bearings have 14" to 16" pounds of rolling Torque then Lock Nut with Cotter Pin (item 11).
6. Install Output Seal (item 3), Coat ID of Seal with light coat of grease. Seal Protector welds to Blade Hub on this style Gearbox., Check Bearing Pre-load Again. Output Shaft Should have NO end play inward or outward. and Bearing MUST be set at a rolling Torque.
7. **Install Input Shaft**, Shaft, Bearings & Gear into Main Housing (item 1)
8. With Gearbox Main Housing laying on its Back Side. Install Inner Input Bearing Cup (item 12 Cup & Cone) into inside of Main Housing. Slide Inner Bearing Cone (item 12 Cup & Cone) into Inner Bearing Cup, Lay Shims (item 13 & 15 a/r) on top of inner Bearing Cone. Lay Input Gear (item 16) in Housing against Shims and inner Bearing Cone. This can be tricky as inner Bearing Cone, Shims and Input Gear ID must line up so Input Shaft (item 30) can drop through them.
9. Slide Sleeve (item 31 Long Sleeve) down on Input Shaft, Slide Outer Bearing Cone (item 12 Cup & Cone) down against Long Sleeve (item 31)
10. Install Outer Bearing Cup (Item 12 Cup & Cone) into front Bearing Cover (item 24), Using Shims (Item 20, 21 & 22 a/r) qaunity as required on Front Bearing Cover, Tighten Bolts in front cover.
11. Check Bearing Pre-Load (should be 14" to 16" pounds of rolling Torque), Change the Bearing Pre-Load by adding or removeing Shims (item 20, 21 & 22) from front Bearing Cover, When Bearing Pre-load is correct go on to Gear Back-Lash between Blade Shaft Gear and Input Gear (should have .017" to .019" back Lash) , Change Gear Back Lash by adding or removeing Gear Shims (item 13 & 15) BUT it is important to make sure what ever you add or remove the same thickness must be changed on Input Bearing Cover shims to keep Bearing Pre-Load correct. in some cases it will be required to change the Shims (item 13 & 15) on Output gear to raise or lower Gear.

Gearbox

P/N 00769927

Assembly Instructions

12. Install Input Seal (item 25) if Bearing Pre-Load and Gear Back-Lash is correct. Coat ID of Seal with light coat of grease before sliding it over input shaft.
13. When this has been Done fill Gearbox with Oil, Before deciding Gearbox is full wait long enough for Oil to run down between Output Shaft Bearing, Then refill with Oil, install Top Cover (using Sealer for Gasket, Oil Plugs and check for leaks, After running Mower 1/2 to 1 hour check Oil Level and recheck for leaks.

NOTE:

The following Gearbox numbers all assemble about the same with the exception of, some part numbers and the location of the input Gear being different

Gear Box #	RPM	Input Gear
00769912.....	540 rpm.....	Front
00769915.....	540 rpm.....	Rear
00769924.....	1000 rpm.....	Front
00769918.....	1000 rpm.....	Front
00769921.....	1000 rpm.....	Rear
00769927.....	1000 rpm.....	Rear
00769930.....	1000 rpm.....	Front
00771225.....	540 rpm.....	Front

Gearbox

P/N 00769930

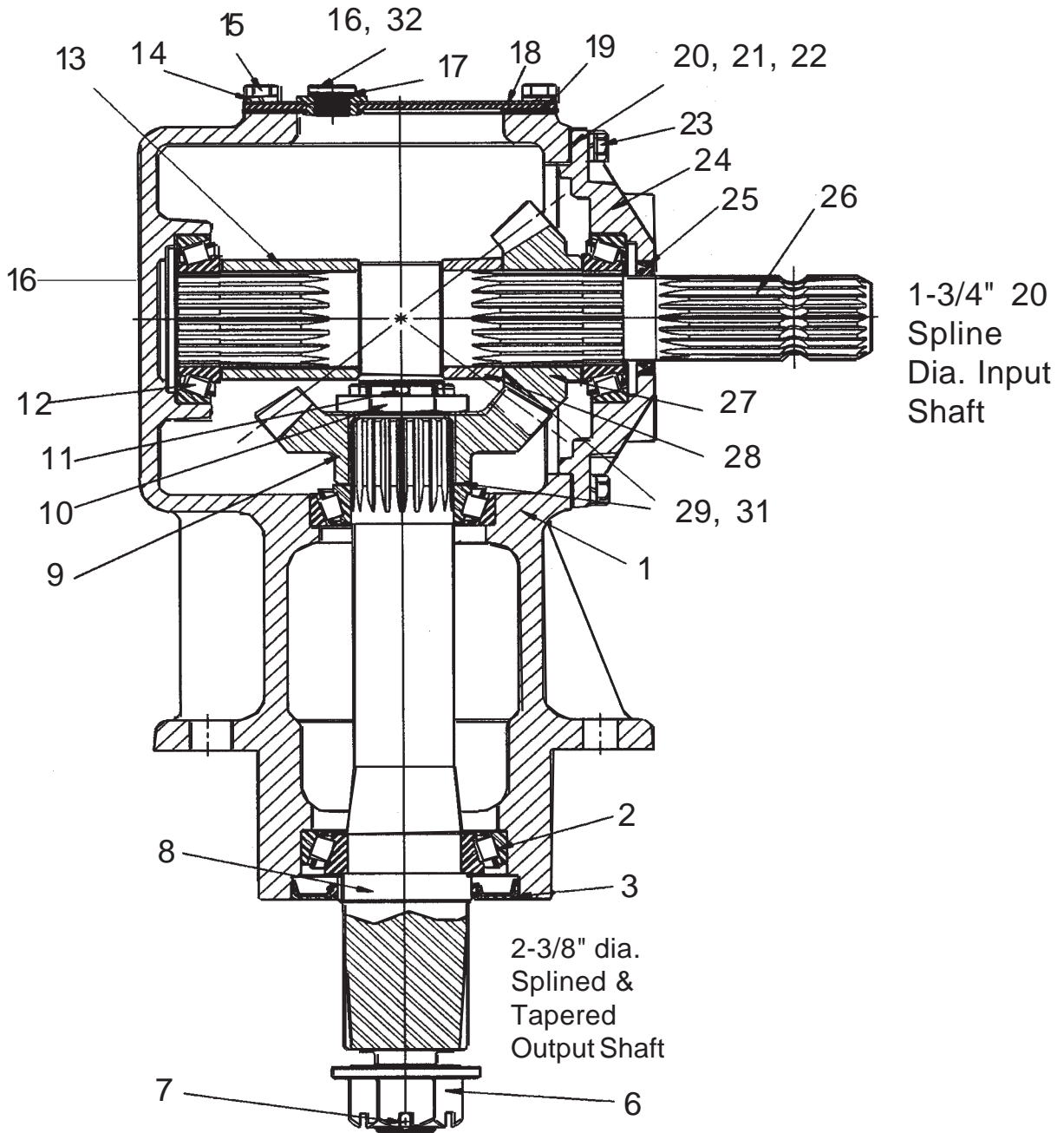

Gearbox

P/N 00769930

Item	Part No.	Qty	Description
	00769930	--	Gearbox Asy, (1000 RPM)
1	00770724	1	Housing
2	00770725	1	Bearing Assembly
3	00770726	1	Oil Seal
6	00771226	1	Nut
7	01422502	1	Cotter Pin
8	00770728	1	Output Shaft
9	00770729	1	Gear, Output (19 Tooth) Center (1000 RPM)
10	00770730	1	Bearing Adjusting Nut
11	00606000	1	Cotter Pin
12	00755628	3	Bearing Assembly
13	00770731	1	Shaft Spacer
14	00766083	12	Washer
15	00754338	4	Bolt
16	00762517	1	Plug, Oil level
17	00769321	3	Washer, Sealing
18	00770732	1	Inspection Cover
19	00770733	1	Inspection Cover Gasket
20	00758646	VAR	Shim Adjustment (0.10)
21	00758647	VAR	Shim Adjustment (0.25)
22	00758648	VAR	Shim Adjustment (0.50)
23	00765905	8	Bolt
24	00770734	1	Input Cap
25	00758653	1	Oil Seal
26	00770735	1	Input Shaft
27	00770736	1	Gear, Input (13 Tooth) Center (1000 RPM)
28	00758657	1	Spacer
29	00758667	VAR	Shim (0.30)
31	00758668	VAR	Shim (0.50)
32	00762114	1	Pressure Plug Vent (To Be Installed before Operating)

NOTE: This Gearbox has a Round Bolt on Top Cover & Input Gear is mounted in the front as shown in drawing

Gearbox

P/N 00769930

Assembly Instructions

Assembly Instructions and Installation Part Numbers are for Gearbox
#00769930 (1000 rpm)

1. **Install Output Shaft** (Blade Shaft), Shaft, Bearings & Gear in Main Housing (1)
2. Install Upper Bearing Cup (Item 12 Cup & Cone) into Main Housing (Item 1) from the top, Install Lower Bearing Cup (item 2 Cup & Cone) into Main housing from the bottom.
3. Install the Lower Bearing Cone (item 2 Cup & Cone) down over Output Shaft. Insert Output Shaft with Bearing Cone on it up through Main Housing from the bottom. Put Upper Bearing Cone (item 12 Cup & Cone) over Output Shaft and slide down till it bottoms out in upper Bearing Cup.
4. Install Shims (item 29 & 31 a/r) as down over top of Output Shaft, The number of shims required will vary, try to use the same amount as were removed. Install Output Gear (item 9) over Output Shaft, Make sure it is seated against Shim. Screw Slotted Bearing Adjusting Nut (item 10) onto top of Output Shaft.
5. Tighten Bearing Adjusting Nut above Gear till Bearings have 14" to 16" pounds of rolling Torque then Lock Nut with Cotter Pin.
6. Install Output Seal (item 3), Coat ID of Seal with light coat of grease. Seal Protector welds to Blade Hub on this style Gearbox., Check Bearing Pre-load Again. Output Shaft Should have NO end play inward or outward. and Bearing MUST be set at a rolling Torque.
7. **Install Input Shaft**, Shaft, Bearings & Gear into Main Housing (item 1)
8. Install Inner Input Bearing Cup (item 12 Cup & Cone) into inside of Main Housing. Slide Inner Bearing Cone (item 12 Cup & Cone) into Inner Bearing Cup, Slide Sleeve (item 13 Long Sleeve) onto back side of Input Shaft (item 26), Holding Sleeve on drop Input Shaft into Housing till it is seated in inner Bearing Cone.
9. Slide Sleeve (item 28 Short Sleeve) down on Input Shaft, Install Shims (item 29 & 31 a/r) on input shaft against short sleeve. Slide Gear down on input shaft. Slide Outer Bearing Cone (item 12 Cup & Cone) down against Gear.
10. Install Outer Bearing Cup (Item 12 Cup & Cone) into front Bearing Cover (item 24), Using Shims (Item 20, 21 & 22 a/r) quantity as required on Front Bearing Cover, Tighten Bolts in front cover.
11. Check Bearing Pre-Load (should be 14" to 16" pounds of rolling Torque), Change the Bearing Pre-Load by adding or removing Shims (item 20, 21 & 22) from front Bearing Cover, When Bearing Pre-load is correct go on to Gear Back-Lash between Blade Shaft Gear and Input Gear (should have .017" to .019" back Lash) , Change Gear Back Lash by adding or removing Gear Shims (item 29 & 31) BUT it is important to make sure what ever you add or remove the same thickness must be changed on Input Bearing Cover shims to keep Bearing Pre-Load correct. in some cases it will be required to change the Shims (item 29 & 31) on Output gear to raise or lower Gear.

Gearbox

P/N 00769930

Assembly Instructions

12. Install Input Seal (item 25) if Bearing Pre-Load and Gear Back-Lash is correct. Coat ID of Seal with light coat of grease before sliding it over input shaft.
13. When this has been Done fill Gearbox with Oil, Before deciding Gearbox is full wait long enough for Oil to run down between Output Shaft Bearing, Then refill with Oil, install Top Cover (using Sealer for Gasket, Oil Plugs and check for leaks, After running Mower 1/2 to 1 hour check Oil Level and recheck for leaks.

NOTE:

The following Gearbox numbers all assemble about the same with the exception of, some part numbers and the location of the input Gear being different

Gear Box #	RPM	Input Gear
00769912.....	540 rpm.....	Front
00769915.....	540 rpm.....	Rear
00769924.....	1000 rpm.....	Front
00769918.....	1000 rpm.....	Front
00769921.....	1000 rpm.....	Rear
00769927.....	1000 rpm.....	Rear
00769930.....	1000 rpm.....	Front
00771225.....	540 rpm.....	Front

GEARBOX

P/N 00770367

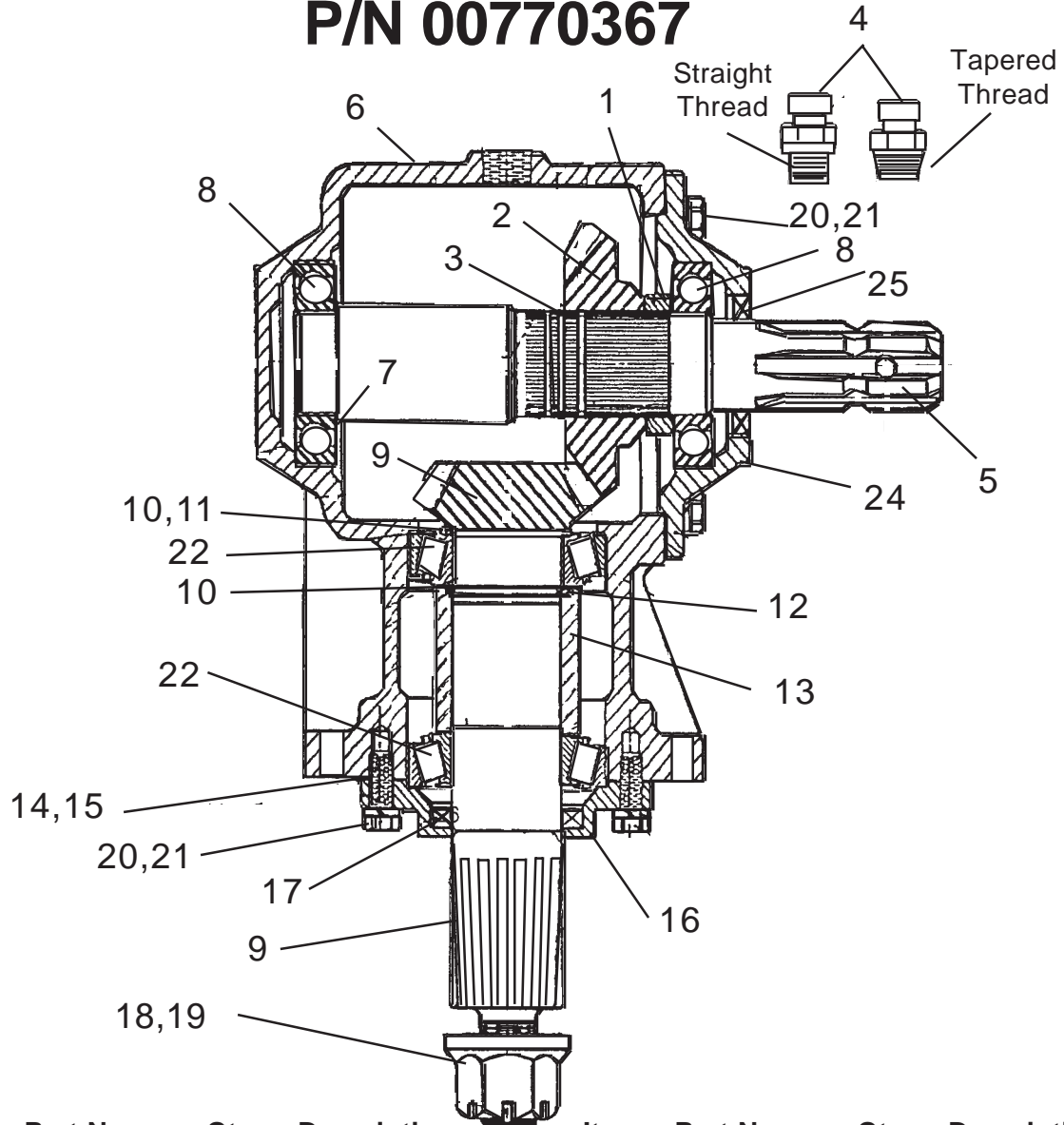

Item	Part No.	Qty	Description	Item	Part No.	Qty	Description
	00770367	--	Gearbox Asy	12	00758660	1	Retaining Ring
1	00770398	1	Spacer, Input Shaft	13	00770368	1	Bearing Spacer
2	00564600	1	Input Gear 22 Tooth	14	00760929	a/r	Gasket 0.30
3	00564100	1	Retaining Ring	15	00760928	a/r	Gasket 0.13
4	00758654	1	Vent Plug (Tapered)	16	00758721	1	Cap, Output
	00762114	1	Vent Plug (Straight)	17	00758674	1	Seal, Output
	00769321	1	Washer (Straight)	18	00758692	1	Nut
5	00770399	1	Input Shaft	19	00606000	1	Cotter Pin
6	00770400	1	Housing	20	00758659	10	Bolt
7	00758671	a/r	Shim (0.20)	21	00755954	10	Lockwasher
8	00563700	2	Bearing	22	00755628	2	Bearing
9	00770401	1	Shaft, Output 15 Tooth	23	00564400	a/r	Gasket 0.30
10	00770402	a/r	Shim, Pinion Adj.	24	00770404	1	Input Cap
11	00770403	1	Shim, Pinion Spacer	25	00564200	1	Seal, Input

G/B Repair Manual 07/02

GEARBOX

P/N 00770367

Assembly Instructions

- 1. Install Output Shaft/Pinion Gear** (item 9) into Main Housing (item 6) install Output Shaft before installing Input Shaft.
- 2.** Install Pinion Shim Spacer (item 11) and Shim / Shims (item 10) onto Output shaft from Bottom. Drop upper Output Shaft Bearing Cup (item 22) onto output Shaft (item 9), Drop Bearing Cone (item 22) onto Output Shaft, Slide Shims (item 10) onto Shaft (when installing Shims try Qty that was removed) Install Retaining Snap Ring (item 12) on output Shaft just below upper Bearing And shims, You should have enough Shims (item 10) that Snap Ring (item 12) holds Bearing, Spacer and Shims snug on Shaft.
- 3.** Install Lower Bearing Space (item 13) on Output Shaft, Note that Bearing Spacer is installed in the correct direction, There is a groove machined in the upper ID to slide over Snap Ring (item 12) if it is not installed this way it will not work.
- 4.** Drop Lower Bearing Cone (item 22) down over Output Shaft, Slide Lower Bearing Cup (item 22) down over Bering Cone. Slide this completed Ouput Shaft with components in to the Main Housing (item 6). Make sure that all components are slid in as far as they will go. Using Lower Bearing Cap Shim Gaskets (item 14 & 15) DO NOT put Gasket Sealer on Gaskets yet & DO NOT install lower Seal. Fit Bearing cap with Gasket Shims (item 14 & 15 down over Output Shaft. Add or remove Gasket Shims to Set Bearing Pre-Load in Output Shaft Bearings, Set Bearing Pre-Load from 14 to 16 inch lbs of rolling torque.
- 5.** When Finished with Step 4 go on to installing Input Shaft or if only replacing Out put shaft go on to set Gear Back-Lash Step 9.
- 6. Install Input Shaft & Gear.** Install Inner Input Shaft Bearing (item 8) into back of Main Housing (item 6), make sure bearing is seated completly into Housing.
- 7.** Install Retaining Ring (item 3) onto input Shaft (item 5), this is the one nearest the middle of the Shaft (Note there are three grooves here make sure to install it in correct one). Slide Input Gear (item 2) down onto input Shaft (item 5) till it is seated against Retaining Ring (item 3). Slide Input Gear Spacer (item 1) down over Shaft till it seat against Input Gear. Slide Outer Input Bearing (item 8) down over Shaft till it seats against Input Gear.
- 8.** Install Shims (item 7) onto inner Brg end of Input Shaft, then Slide shaft w/ components into Gearbox Main Housing. Using Gasket/ Shims (item 23 Don't use gasket sealer or Install Input seal at this time) slide Input Bearing Cap (item 24) on over Input Shaft, Tighten till end Play is removed from Input Shaft by adding or removing gaskets.
- 9.** Gear Back-Lash is set by moving Shims at upper Output Shaft Brg from below Brg to above or Vice Versa. Also it can be changed by removeing or adding Shims (item 7) on Input Shaft. Gear Back-Lash should be from .016" to .019"
- 10.** If Brg Back lash is OK remove Bearing Caps (item 16 & 24), Check Seal areas and install Seal. Use Gasket sealer now if wanted & re-install Brg caps. Re-check Bearing Back Lash & Lower Bearing Pre-Load.
- 11.** Fill Gearbox with oil. DO NOT Fill with Oil above Oil Level Plug. Wait a while let Gearbox sit and have time for Oil to run down into lower Bearings and recheck Oil Level. ALWAYS recheck Oil Level after running Mower 1/2 to 1 hour. Inspect Seals for leaking after filling with Oil and after running 1/2 to 1 hour.

Gearbox

P/N 00771225

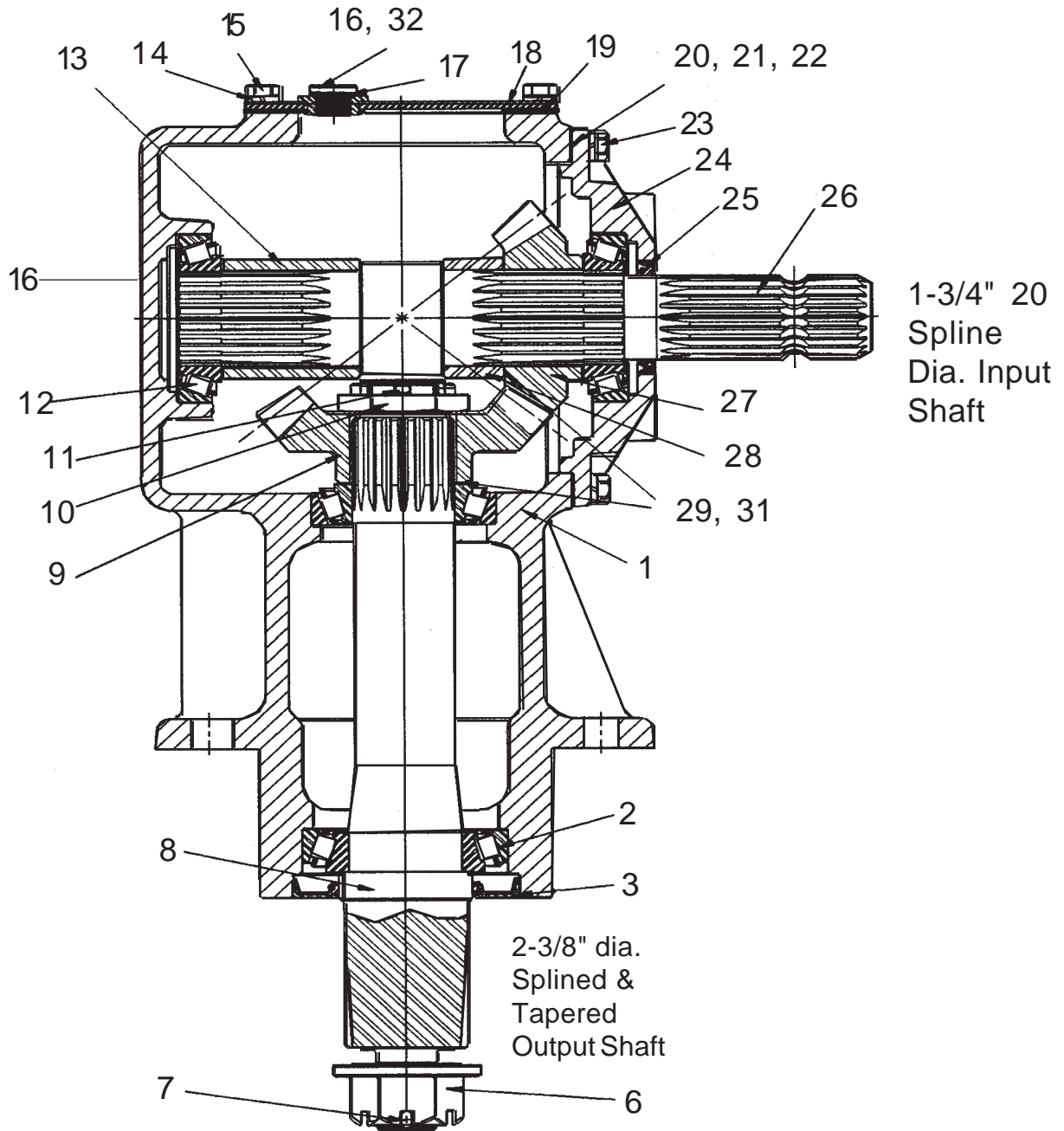

Gearbox

P/N 00771225

Item	Part No.	Qty	Description
	00771225	--	Gearbox Asy, (540 RPM)
1	00770724	1	Housing
2	00770725	1	Bearing Assembly
3	00770726	1	Oil Seal
6	00771226	1	Nut
7	01422502	1	Cotter Pin
8	00770728	1	Output Shaft
9	00770736	1	Gear, Output 13 Tooth (540 RPM)
10	00762121	1	Bearing Adjusting Nut
11	00606000	1	Cotter Pin
12	00755628	3	Bearing Assembly
13	00770731	1	Shaft Spacer
14	00766083	12	Washer
15	00754338	4	Bolt
16	00762517	1	Plug, Oil level
17	00769321	3	Washer, Sealing
18	00770732	1	Inspection Cover
19	00770733	1	Inspection Cover Gasket
20	00758646	VAR	Shim Adjustment (0.10)
21	00758647	VAR	Shim Adjustment (0.25)
22	00758648	VAR	Shim Adjustment (0.50)
23	00765905	8	Bolt
24	00770734	1	Input Cap
25	00758653	1	Oil Seal
26	00770735	1	Input Shaft
27	00770736	1	Gear, Input 13 Tooth (540 RPM)
28	00758657	1	Spacer
29	00758667	VAR	Shim (0.30)
31	00758668	VAR	Shim (0.50)
32	00762114	1	Pressure Plug Vent (To Be Installed before Operating)

NOTE: This Gearbox has a Round Bolt on Top Cover & Input Gear is mounted in the front as shown in drawing

Gearbox

P/N 00771225

Assembly Instructions

Assembly Instructions and Installation Part Numbers are for Gearbox
#00771225 (540 rpm)

1. **Install Output Shaft** (Blade Shaft), Shaft, Bearings & Gear in Main Housing (1)
2. Install Upper Bearing Cup (Item 12 Cup & Cone) into Main Housing (Item 1) from the top, Install Lower Bearing Cup (item 2 Cup & Cone) into Main housing from the bottom.
3. Install the Lower Bearing Cone (item 2 Cup & Cone)) down over Output Shaft. Insert Output Shaft with Bearing Cone on it up through Main Housing from the bottom. Put Upper Bearing Cone (item 12 Cup & Cone) over Out Put Shaft and slide down till it bottoms out in upper Bearing Cup.
4. Install Shims (item 29 & 31 a/r) as down over top of Output Shaft, The number of shims required will vary, try to use the same amount as were removed. Install Output Gear (item 9) over Output Shaft, Make sure it is seated against Shim. Screw Slotted Bearing Adjusting Nut (item 10) onto top of Output Shaft.
5. Tighten Bearing Adjusting Nut above Gear till Bearings have 14" to 16" pounds of rolling Torque then Lock Nut with Cotter Pin.
6. Install Output Seal (item 3), Coat ID of Seal with light coat of grease. Seal Protector welds to Blade Hub on this style Gearbox., Check Bearing Pre-load Again. Output Shaft Should have NO end play inward or outward. and Bearing MUST be set at a rolling Torque.
7. **Install Input Shaft**, Shaft, Bearings & Gear into Main Housing (item 1)
8. Install Inner Input Bearing Cup (item 12 Cup & Cone) into inside of Main Housing. Slide Inner Bearing Cone (item 12 Cup & Cone) into Inner Bearing Cup, Slide Sleeve (item 13 Long Sleeve) onto back side of Input Shaft (item 26), Holding Sleeve on drop Input Shaft into Housing till it is seated in inner Bearing Cone.
9. Slide Sleeve (item 28 Short Sleeve) down on Input Shaft, Install Shims (item 29 & 31 a/r) on input shaft against short sleeve. Slide Gear down on input shaft. Slide Outer Bearing Cone (item 12 Cup & Cone) down against Gear.
10. Install Outer Bearing Cup (Item 12 Cup & Cone) into front Bearing Cover (item 24), Using Shims (Item 20, 21 & 22 a/r) qaunity as required on Front Bearing Cover, Tighten Bolts in front cover.
11. Check Bearing Pre-Load (should be 14" to 16" pounds of rolling Torque), Change the Bearing Pre-Load by adding or removeing Shims (item 20, 21 & 22) from front Bearing Cover, When Bearing Pre-load is correct go on to Gear Back-Lash between Blade Shaft Gear and Input Gear (should have .017" to .019" back Lash) , Change Gear Back Lash by adding or rmoveing Gear Shims (item 29 & 31) BUT it is important to make sure what ever you add or remove the same thickness must be changed on Input Bearing Cover shims to keep Bearing Pre-Load correct. in some cases it will be required to change the Shims (item 29 & 31) on Output gear to raise or lower Gear.

Gearbox

P/N 00771225

Assembly Instructions

12. Install Input Seal (item 25) if Bearing Pre-Load and Gear Back-Lash is correct. Coat ID of Seal with light coat of grease before sliding it over input shaft.
13. When this has been Done fill Gearbox with Oil, Before deciding Gearbox is full wait long enough for Oil to run down between Output Shaft Bearing, Then refill with Oil, install Top Cover (using Sealer for Gasket, Oil Plugs and check for leaks, After running Mower 1/2 to 1 hour check Oil Level and recheck for leaks.

NOTE:

The following Gearbox numbers all assemble about the same with the exception of, some part numbers and the location of the input Gear being different

Gear Box #	RPM	Input Gear
00769912.....	540 rpm.....	Front
00769915.....	540 rpm.....	Rear
00769924.....	1000 rpm.....	Front
00769918.....	1000 rpm.....	Front
00769921.....	1000 rpm.....	Rear
00769927.....	1000 rpm.....	Rear
00769930.....	1000 rpm.....	Front
00771225.....	540 rpm.....	Front

GEARBOX

P/N 00775919

Item	Part No.	Qty	Description
	00775919	1	Gearbox Asy (540 RPM)
1	00775921	1	Housing
2	00755954	8	Lockwasher
3	00758659	8	Bolt
4	00758664	4	Input Cap
5	00758689	1	Input Shaft
6	00773640	1	Input Seal
7	00758667	AR	Shim
8	00758668	AR	Shim
9	00758646	AR	Input Cap Gasket
10	00758647	AR	Input Cap Gasket
11	00759977	1	Spacer
12	00775923	1	Output Spacer
13	00758663	1	Output Cap
14	00758672	4	Lockwasher
15	02959661	4	Bolt
17	00606000	1	Cotter Pin
18	00758692	1	Flanged Nut
19	00758674	1	Oil Seal
20	00758676	AR	Gasket
21	00758677	AR	Gasket
22	00775922	1	Output Shaft
23	00769938	2	Bearing Assembly
24	00758693	1	Gear, Output 13 Tooth (540 RPM)
25	00770730	1	Bearing Adjusting Nut
26	00770421	1	Cotter Pin
27	00755615	2	Bearing Assembly
28	00770737	2	Drain Plug
29	00769321	3	Sealing Washer
30	00758657	1	Spacer
31	00758694	1	Gear, Input 19 Tooth (540 RPM)
32	00762114	1	Vent Plug
33	00750952	6	Bolt
	00756077	6	Washer
	00695100	6	Locknut

NOTE: This Gearbox Has a 1-3/4" X 20 Spline Input Shaft & a one piece Lower Bearing Spacer

GEARBOX

P/N 00775919

Assembly Instructions

Assembly Instruction Gearbox # 00775919 (540 RPM)

- 1. Install Output Shaft** (Blade Shaft), Bearings, Gear in Main Housing (#00775921)
- 2.** Install Lower Bearing Cone (#00769938 Cup & Cone) on Output Shaft (#00775922) make sure Bearing cone slides all the way down against shoulder at bottom of shaft. Slide Bearing Cup (part of #00769938) down over Bearing Cone.
- 3.** Install the 1 piece Bearing Spacer (#00775923) down over Output Shaft. Put Upper Bearing Cup (#00769938 Cup & Cone) over Shaft and slide down till it sits against Bearing Spacer. Slide upper Bearing Cone (#00769938 Cup & Cone) down over Output Shaft till it is against Bearing Cup.
- 4.** Slip Shaft with Bearings and Spacer into the Bottom Side of Main Housing, Push in shaft till upper Bearing cup is bottomed out in Main Housing.
- 5.** Slide Gear Spacer (#00759977) down over Shaft and against Upper Bearing Cone, Install Shims (#00758667 and #00758668) over Shaft, Quantity of Shims will vary, try to use same amount as was taken off. install Output Gear (#00758693 a 13 tooth gear) down over output Shaft. Install Slotted Hex Bearing Adjusting Nut (# 00770730) with Cotter Pin (#00770421), this type WILL NOT use a Hardened Flat Washer between Nut & Gear.
- 6.** Tighten Bearing Adjusting Nut above Gear till Bearings have 14" to 16" pounds of rolling Torque then Lock Nut, either with Bendup Tabs or Cotter Pin depending which type you have.
- 7.** Install Output Seal (#00758692) into Lower Output Cap (#00758663), Coat ID of Seal with light coat of grease. Using Shims (#00758676 and #00758677) quantity may vary according to how large space is between Cap and Main Housing. DO USE gasket sealer on shims at this time, Install Output Cap and tighten Bolts. Check Bearing Pre-load, If correct amount of Shims used it should not have changed. Check Bearing Pre-load Again. Output Shaft Should have NO end play inward or outward. and Bearing MUST be set at a rolling Torque.
- 8. Install Input Shaft** (PTO end), Bearings, Gear in Main Housing (#00775921)
- 9.** Install Gear Spacer (#00758657) and inner Bearing Cone onto Input Shaft. Install Shim (#00758667 & #00758668) on Shaft next to Gear Spacers (the quantity will vary, try to put same as taken off), Slide Input Gear (#00758694 a 19 tooth gear) on till it is against against Shims, Install Front Input Shaft Bearing Cone (#007585615 Cup & Cone) on front of Input Shaft making sure it is against Shims. Install Rear Input Shaft Bearing Cone (#00758650 Cup & Cone) on rear of input Shaft making sure it is against shoulder on Shaft.
- 10.** Install Rear Input Bearing Cup (#00755615 Cup & Cone) into Rear of Main Housing. lower Input Shaft (with Gears, Spacers, Shims and Bearing Cones on it) down into Main housing from front side. Install Bearing Cup (#00755615 Cup & Cone) into Front Input Bearing Cap (#00758664), Install Input Seal (#00773640) into Front Bearing Cap, Coat ID of Seal with light coat of grease. Using Shims/Gaskets (#00758646 and #00758647) on front cover set it down over input shaft, Tighten Front cover Bolts. The Quantity will vary so DO NOT put Gasket Sealer on the at this time as they may have to be removed.

GEARBOX

P/N 00775919

Assembly Instructions

- 11.** Check Bearing Pre-Load (should be 14" to 16" pounds of rolling Torque) and Gear Back Lash between Blade Shaft Gear and Input Gear (should have .017" to .019" back Lash) If it is not correct, Move Shim from one side of input gear to other to Get Correct Back Lash, It may be required to add or remove shims from Blade Shaft output Gear to raise or lower it to get correct Back lash. Once all is correct add Gasket Sealet to front input cover gasket and reinstall it. Tighten front cover bolts and recheck Gear Back-Lash and Bearing Pre-Load settings.
- 12.** When this has been Done fill Gearbox with Oil, Before deciding Gearbox is full wait long enough for Oil to run down between Output Shaft Bearing, Then refill with Oil, install Oil Plugs and check for leaks, After running Mower 1/2 to 1 hour check Oil Level and recheck for leaks.

Gearbox P/N 02978513

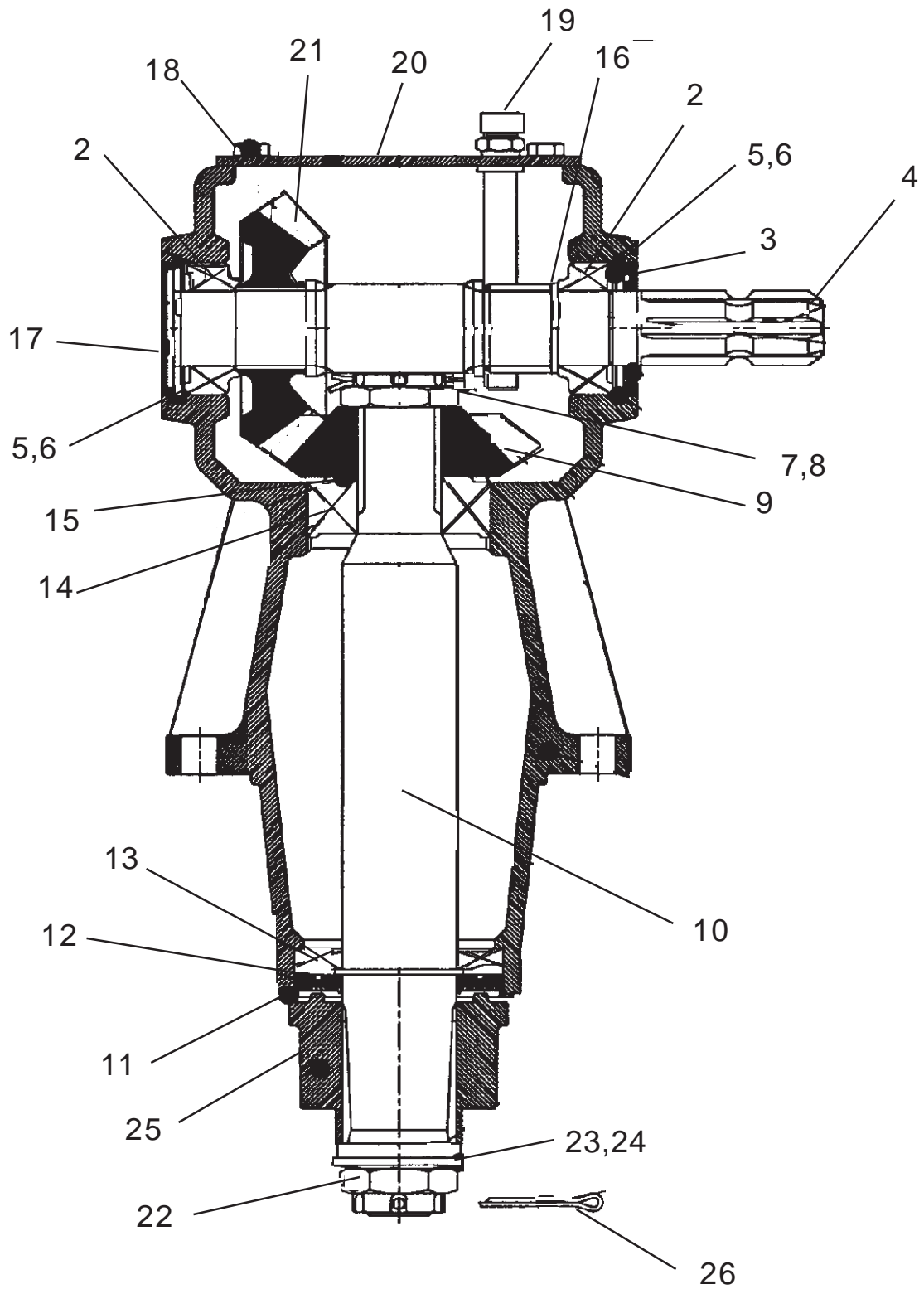

Gearbox

P/N 02978513

Item	Part No.	Qty.	Description
	02978513	-	Gearbox Asy, (540 RPM)
1	02978747	1	Casing
2	02978748	2	Bearing
3	02978733	1	Oil seal
4	02978749	1	Input shaft
5	02978750	2	Snap ring
6	02978751	2	Shim
7	02978752	1	Cotter pin
8	02978753	1	Nut
9	02978754	1	Gear, (540 RPM)
10	02978758	1	Shaft, Input
11	02978755	1	Seal Protector
12	02978756	1	Oil seal
13	02978757	1	Bearing
14	02978759	1	Bearing
15	02978760	1	Shim
16	02978761	1	Shim
17	02978762	1	Cap
18	02978763	4	Bolt
19	02978764	1	Plug
20	02978765	1	Cover
21	02978766	1	Gear, (540 RPM)
22	02978767	1	Castle nut
23	02978768	1	Flat washer
24	02978769	1	Washer, disc spring
25	02978770	1	Splined hub (Welded to Blade Carrier)
26	02978771	1	Cotter pin

Gearbox

P/N 02978513

Assembly Instructions

Installation Part Numbers are for Gearbox #002978513 (540 RPM)

1. **Installing Output Shaft** (Blade Shaft), Bearings, Gear in Main Housing (Item 1) using same amount of Shims removed & adding or deleting to adjust.
2. Install Upper Bearing Cup (item 14) into Main Housing (item 1) from the top, Install Lower Bearing Cup (Item 13) into Main housing from the bottom.
3. Install the Lower Bearing Cone (item 13) down over Output Shaft (item 10). Insert Output Shaft with Bearing Cone on it up through Main Housing from the bottom. Put Upper Bearing Cone (item 14) over Output Shaft and slide down till it bottoms out in upper Bearing Cup.
4. Install Shims (item 15) down over top of Output Shaft, The number of shims required will vary, try to use the same amount as were removed. Install Output Gear (item 9) over Output Shaft, Make sure it is seated against Shim. Screw Slotted Bearing Adjusting Nut (item 8) onto top of Output Shaft.
5. Tighten Bearing Adjusting Nut above Gear till Bearings have 14" to 16" pounds of rolling Torque, Tap Shaft using a coated Hammer or a Brass Drift pin to insure Bearings are seated straight then recheck Bearing rolling Torque. Secure Bearing Adjusting Nut with Cotter Pin and bend it over.
6. DO NOT Install Output Seal (item 12) or Seal Protector (item 11) now, wait till Input Shaft has been installed, When you do install it Coat ID of Seal with light coat of grease. Install Seal Protector (Item 11), this drives into lower Main Housing, This Seal Protector Should always be replaced with new one after being removed. Re-Check Bearing Pre-load. Output Shaft Should have NO end play and Bearing MUST be set at a rolling Torque. (See Step 5.)
7. **Installing Input Shaft**, Bearings and Gear into Main Housing (item 1) using same amount of Shims as were removed and adding or deleting to adjust. in Step 8 below the procedure is for a gear in the Back, when install where gear is in the back shaft is installed from the front of main housing.
8. Holding Gear (item 21) in Gearbox Housing from top opening, Slide Input Shaft through front side of Main Housing (item 1) and through input Gear (item 21) till shaft sticks out the Back of Main Housing. Slide Shims (item 16) on Shaft till they seat against Shoulder on front side of Shaft. Slide Front Input Bearing Cone (item 2) with smaller end pointing out onto front of input shaft till it seats against Shims (item 16). Slide Front Bearing Cup (item 2) onto front of input shaft and into Main Housing till it is seated against Bearing Cone. Install Shims (item 6) into front of main housing till they are against Bearing Cup. Install Snap ring (item 5). DO NOT INSTALL ANY SEALS YET
9. Install Rear Input Bearing Cone (item 2) into Rear of Main Housing till it is against Shoulder on Shaft, Install Bearing Cup (item 2) into rear of main housing, Install Shims (item 6) in against Bearing Cup try to use the same amount of shims as were removed. Install Internal Clip (item 5) into Main Housing against Shims. DO NOT install any Seals at this time. Check Bearing Pre-Load now, it should be 14" to 16" lbs of rolling Torque, remove or add Shims (item 6) to adjust.

Gearbox

P/N 02978513

Assembly Instructions

10. Check Gear Back-Lash between Blade Shaft Gear and Input Gear (should have .017" to .019" back Lash) If it is not correct, moving shims (item 6) on Input Shaft Bearings from front to back or vice versa will change Bearing Back lash (Note moving Shims from front to back will not change Bearing Preload BUT removing or adding them will), It may be required to add or remove shims from Blade Shaft output Gear to raise or lower it to get correct Back-lash. Once all is correct Coat all Seal ID with light coat of grease. Install Input Seal (3) and Rear Seal Cap (item 17) then recheck Gear and Bearing settings. Now is the time to install Output seal (item 12) and lower seal protector (item 11),
11. Install Top Cover (item 20) now using a good quality of Form-a-gasket material, or fill Gearbox with Oil (see step 12) then install Topcover, Install Vent Plug / Dip Stick (item 19) in to top Cover.
12. When this has been Done fill Gearbox with Oil, Before deciding Gearbox is full wait long enough for Oil to run down between Output Shaft Bearing, Then refill with Oil, install Top Cover (using Sealer for Gasket), Oil Plugs and check for leaks, After running Mower 1/2 to 1 hour check Oil Level and recheck for leaks.

NOTE: The Following Gearboxes will assemble the same as the above with very minor differences, some componet numbers and the location of the Input gear.

Gear Box #	RPM	Input Gear
02978513.....	540 rpm.....	Rear
02978523*	540 rpm.....	Rear
02978971.....	1000 rpm.....	Rear
02978533.....	1000 rpm.....	Front
02978523*	1000 rpm.....	Rear

* 02978523 used same gearbox as 540 or 1000 ratio changed through the Divider Gearbox on Flex Wing Cutter.

GEARBOX P/N 02978514

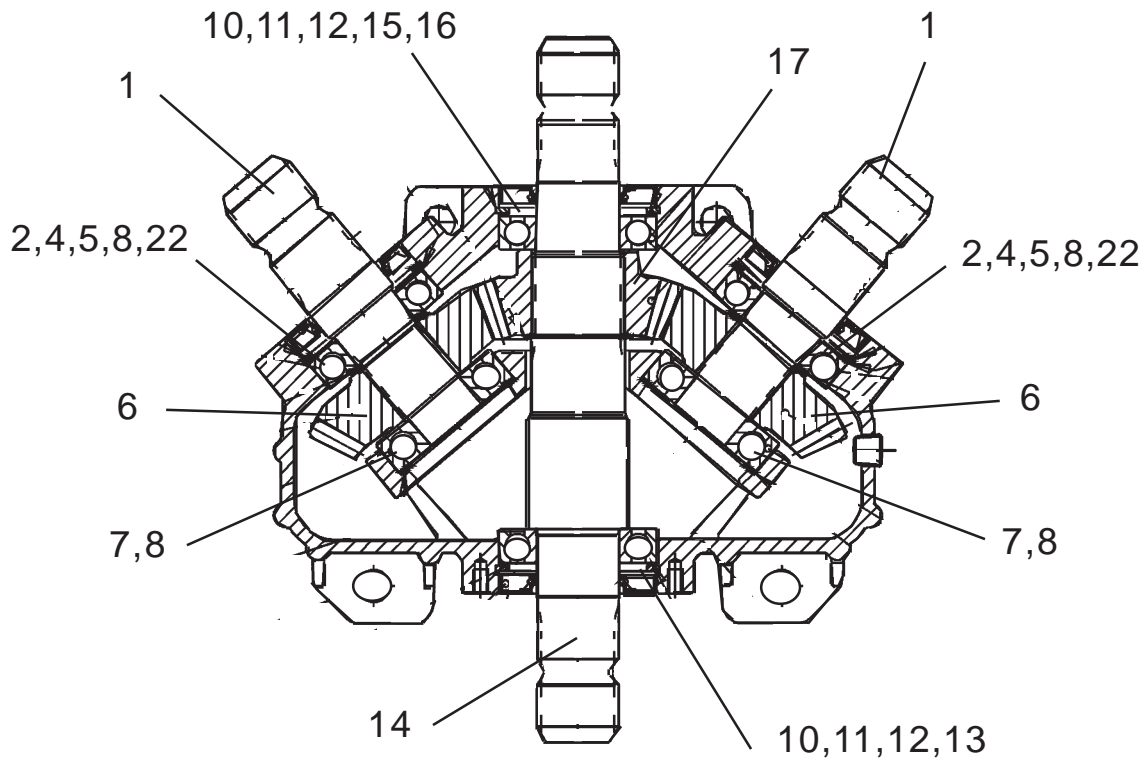
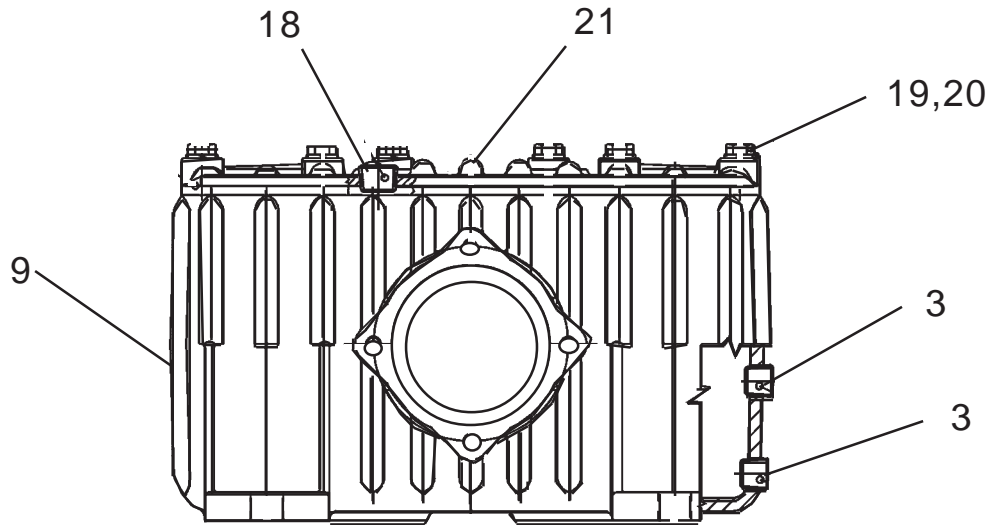

GEARBOX

P/N 02978514

Item	Part No.	Qty.	Description
	02978514	-	Gearbox Asy. (540 RPM)
1	02978732	2	Shaft 1-3/4" X 20 Spline
2	02978733	2	Oil Seal
3	02978731	2	Plug
4	02978735	2	Snap Ring
5	02978734	2	Bearing
6	02978736	2	Gear, (540 RPM)
7	02978734	2	Bearing
8	02978737	2	Shim Kit
9	02978738	1	Casing
10	02978739	2	Snap Ring Lining
11	02978740	2	Oil Seal
12	02978741	2	Shim
13	02978742	1	Bearing
14	02978743	1	Shaft 1-3/4" X 20 Spline
15	02978744	1	Snap Ring
16	02978742	1	Bearing
17	02978746	1	Gear, (540 RPM)
18	02978727	1	Plug
19	02978730	6	Spring Washer
20	02978729	6	Bolt
21	02978728	1	Cover, Top
22	000944	4	Lock Nut, (f/mounting Gearbox)
23	00753753	4	Bolt, (f/mounting Gearbox0

GEARBOX

P/N 02978514

Assembly Instructions

Installation Part Numbers are for Gearbox #02978514 (540 RPM)

- 1. Install Center Input / Output Shaft** (item 14) , with Bearings, Gear and components as shown in Drawing into Main Housing (Item 9), install Input shaft before installing Output Shafts to Wings, Notice Item 12, these are Shim Washers (Compensating Rings) to keep end play out of Shaft. there may be one ore more used. **DO NOT INSTALL ANY SEALS TILL GEARBOX IS COMPLETELY ASSEMBLED !** Before you install the seals check the openings for burrs or scratches that will damage or prevent the OD of the seal from sealing. Remove any Burrs and fill scratch with good gasket Sealer
- 2.** Install Snap Ring (Item 10) in Back of Housing (Item 9), this will retain Rear bearing (item 16) **DO NOT** install Rear Seal (item 11) at this time. Install Front Shims (item 12), Qty use same as was removed as this amount can vary. Slide rear Bearing (item 16) into housing (item 9) this can be done from inside. Push Bearing in till it seats against the Shims & Snap Ring (items 10 & 12).
- 3.** Holding Input Gear (item 17) into Gearbox Housing (item 9) from the top slide the Input Shaft (item 14) into the Housing from the front. Slide Shaft through Gear and Rear Bearing.
- 4.** Install Front Bearing (item 13) on input Shaft from the front. Slide Bearing till it goes into Geabox Housing and seats against Shoulder on Input Shaft. Install Shims (item 12) using quantity that will will allow end play to be removed, This is a trial & error method because you will need to install Snap Ring (item 10) to check then remove it to add or remove Shims. These are ball Bearings so they will not have Pre-Load. **DO NOT** install Front Seal (item 11) at this time.
- 5.** Install Output Shaft to Side Drives, The Left & Right Shafts will install the Same using the same Part Numbers. it is best to install Parts for both Side Drive Shafts at same time.
- 6.** Looking down into gearbox Housing (item 9) you can see the inner casting for the Inner Bearing (item 7), There will be adjusting Shims (item 8) that need to be installed here before Bearing is. The quantity of Shims will vary, Try the same amount as was removed here. Install the inner Bearing (item 7) into Housing.
- 7.** Side Output Shaft (item 1) has a Snap Ring Grove on it near outer Bearing (item 5)area. Slide Outer Bearing (item 5) onto Side Shaft (item 1) till it seats against Shoulder on Shaft. Install Snap Ring (item 22) on Shaft next to Bearing.
- 8.** Take the Gear for Side Drive (item 6) and slide it down into Gearbox from the Top, With the side Drive Gear in position against the Input Gear (item 17), take the Side drive Shaft (item 1) and Slide it through the Housing from the out side, rotating Shaft as you push it through to align Splines on shaft with spline in Gear. Push the Shaft in till the Bearing is into Housing and the shoulder on Shaft seats against inner Bearing.

GEARBOX

P/N 02978514

Assembly Instructions

- 9.** From the outside install Shims in against Outer Bearing, use quantity to remove end play, install Snap Ring (item 4) to retain Components of Side Out put Shaft. DO NOT install Seals at this time.
- 10.** it is now time to check Gear Back-Lash and Seating of gears Heal to Toe, The Back-Lash and Seating of gears can be changed by moving Shims (item 12) on center Shaft and (item 8) on Side Drive Shafts. this is a trial & error Method of adding & removing Shims. Do This till the Gear Back Lash is .016" to .019" and Gear seating is even Heal to Toe.
- 11.** Coat all Shafts & ID of seals with a light coat of Grease before installing Seals. Install Seals Now, if the openings for the seals have not been inspected as explained in Step 1, do so now before installing Seals.
- 12.** Install top cover using Gasket sealer, Fill Gearbox with oil. Gearbox can be filled with oil before top cover is installed if wanted. DO NOT Fill with Oil above Oil Level Plug. Always check for Oil Leaks before Running Mower and Always recheck Oil Level, Inspect Seals for Leaking, Excessive end play in Shaft after running Mower 1/2 to 1 hour

Gearbox

P/N 02978523

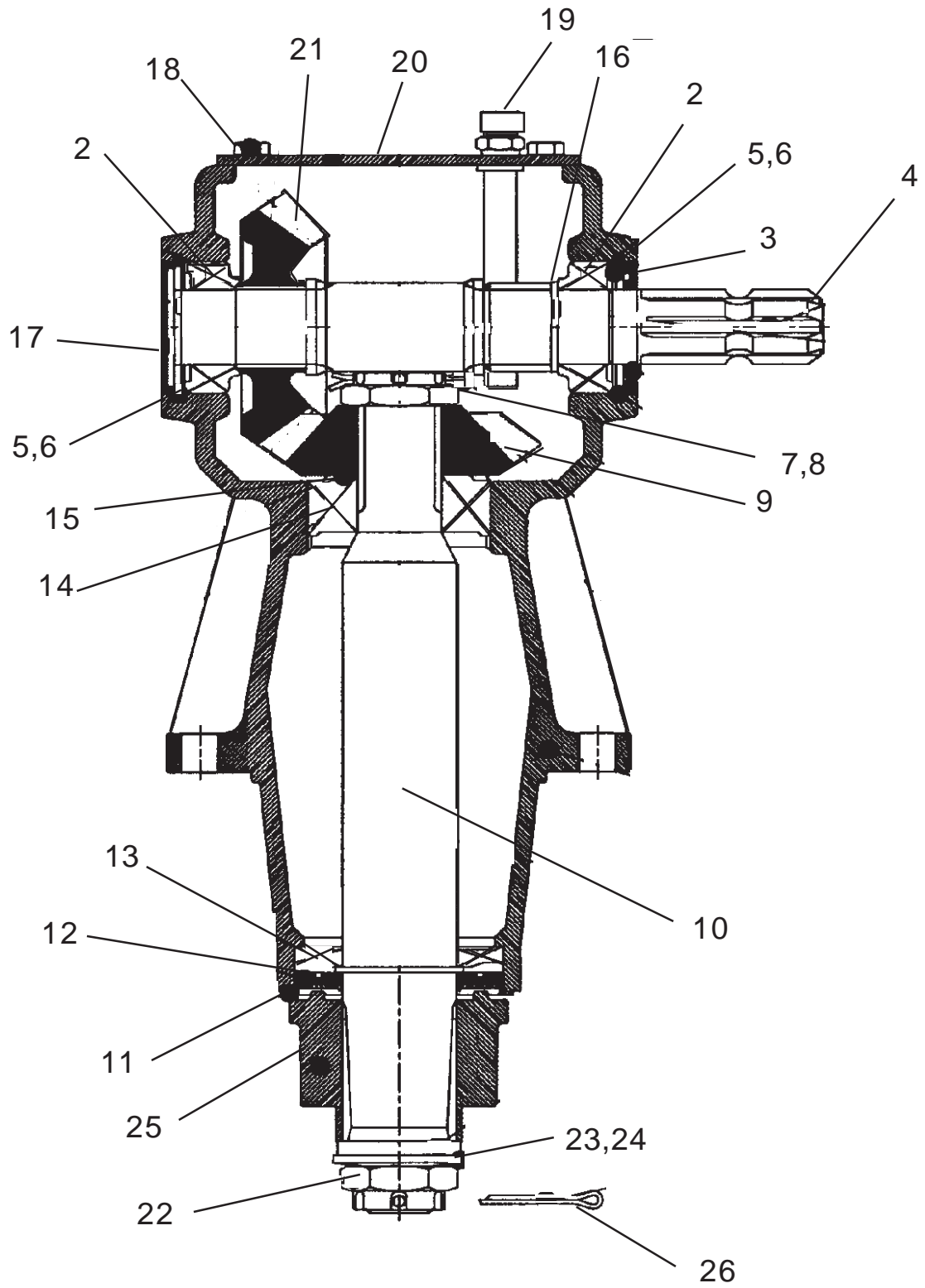

Gearbox

P/N 02978523

Item	Part No.	Qty.	Description
	02978523	-	Gearbox Asy, (540 or 1000 RPM)
1	02978747	1	Casing
2	02978748	2	Bearing
3	02978733	1	Oil seal
4	02978749	1	Input shaft
5	02978750	2	Snap ring
6	02978751	2	Shim
7	02978752	1	Cotter pin
8	02978753	1	Nut
9	02978772	1	Gear, 540 or 1000 RPM
10	02978758	1	Shaft, Input
11	02978755	1	Seal Protector
12	02978756	1	Oil seal
13	02978757	1	Bearing
14	02978759	1	Bearing
15	02978760	1	Shim
16	02978761	1	Shim
17	02978762	1	Cap
18	02978763	4	Bolt
19	02978764	1	Plug
20	02978765	1	Cover
21	02978773	1	Gear, (540 or 1000 RPM)
22	02978767	1	Castle nut
23	02978768	1	Flat washer
24	02978769	1	Washer, disc spring
25	02978770	1	Splined hub (Welded to Blade Carrier)
26	02978771	1	Cotter pin

Gearbox

P/N 02978523

Assembly Instructions

Installation Part Numbers are for Gearbox #002978523 (540 or 1000 RPM)

1. **Installing Output Shaft** (Blade Shaft), Bearings, Gear in Main Housing (Item 1) using same amount of Shims removed & adding or deleting to adjust.
2. Install Upper Bearing Cup (item 14) into Main Housing (item 1) from the top, Install Lower Bearing Cup (Item 13) into Main housing from the bottom.
3. Install the Lower Bearing Cone (item 13) down over Output Shaft (item 10). Insert Output Shaft with Bearing Cone on it up through Main Housing from the bottom. Put Upper Bearing Cone (item 14) over Output Shaft and slide down till it bottoms out in upper Bearing Cup.
4. Install Shims (item 15) down over top of Output Shaft, The number of shims required will vary, try to use the same amount as were removed. Install Output Gear (item 9) over Output Shaft, Make sure it is seated against Shim. Screw Slotted Bearing Adjusting Nut (item 8) onto top of Output Shaft.
5. Tighten Bearing Adjusting Nut above Gear till Bearings have 14" to 16" pounds of rolling Torque, Tap Shaft using a coated Hammer or a Brass Drift pin to insure Bearings are seated straight then recheck Bearing rolling Torque. Secure Bearing Adjusting Nut with Cotter Pin and bend it over.
6. DO NOT Install Output Seal (item 12) or Seal Protector (item 11) now, wait till Input Shaft has been installed, When you do install it Coat ID of Seal with light coat of grease. Install Seal Protector (Item 11), this drives into lower Main Housing, This Seal Protector Should always be replaced with new one after being removed. Re-Check Bearing Pre-load. Output Shaft Should have NO end play and Bearing MUST be set at a rolling Torque. (See Step 5.)
7. **Installing Input Shaft**, Bearings and Gear into Main Housing (item 1) using same amount of Shims as were removed and adding or deleting to adjust. in Step 8 below the procedure is for a gear in the front, when install where gear is in the back shaft is installed from the front of main housing.
8. Holding Gear (item 21) in Gearbox Housing from top opening, Slide Input Shaft through Front side of Main Housing (item 1) and through input Gear (item 21) till shaft sticks out the Back of Main Housing. Slide rear Input Bearing Cone (item 2) with smaller end pointing out onto rear of input shaft till it seats against Gear (item 21) . Slide rear Bearing Cup (item 2) onto rear of input shaft and into Main Housing till it is seated against Bearing Cone. Install Shims (item 6) into front of main housing till they are against Bearing Cup. Install Snap ring (item 5). DO NOT INSTALL ANY SEALS YET
9. Install Shims (item 16) onto front of Input Shaft and install front Input Bearing Cone (item 2) into front of Main Housing till it is against Shoulder / Shims on Shaft, Install Bearing Cup (item 2) into front of main housing, Install Shims (item 6) in against Bearing Cup try to use the same amount of shims as were removed. Install Internal Clip (item 5) into Main Housing against Shims. DO NOT install any Seals at this time. Check Bearing Preload now, it should be 14" to 16" lbs of rolling Torque, remove or add Shims (item 6) to adjust.

Gearbox

P/N 02978523

Assembly Instructions

10. Check Gear Back-Lash between Blade Shaft Gear and Input Gear (should have .017" to .019" back Lash) If it is not correct, moving shims (item 6) on Input Shaft Bearings from front to back or vice versa will change Bearing Back lash (Note moving Shims from front to back will not change Bearing Preload BUT removing or adding them will), It may be required to add or remove shims from Blade Shaft output Gear to raise or lower it to get correct Back-lash. Once all is correct Coat all Seal ID with light coat of grease. Install Input Seal (3) and Rear Seal Cap (item 17) then recheck Gear and Bearing settings. Now is the time to install Output seal (item 12) and lower seal protector (item 11),
11. Install Top Cover (item 20) now using a good quality of Form-a-gasket material, or fill Gearbox with Oil (see step 12) then install Topcover, Install Vent Plug / Dip Stick (item 19) in to top Cover.
12. When this has been Done fill Gearbox with Oil, Before deciding Gearbox is full wait long enough for Oil to run down between Output Shaft Bearing, Then refill with Oil, install Top Cover (using Sealer for Gasket), Oil Plugs and check for leaks, After running Mower 1/2 to 1 hour check Oil Level and recheck for leaks.

NOTE: The Following Gearboxes will assemble the same as the above with very minor differences, some componet numbers and the location of the Input gear.

Gear Box #	RPM	Input Gear
02978513.....	540 rpm.....	Rear
02978523*	540 rpm.....	Rear
02978971.....	1000 rpm.....	Rear
02978533.....	1000 rpm.....	Front
02978523*	1000 rpm.....	Rear

* 02978523 used same gearbox as 540 or 1000 ratio changed through the Divider Gearbox on Flex Wing Cutter.

Gearbox

P/N 02978533

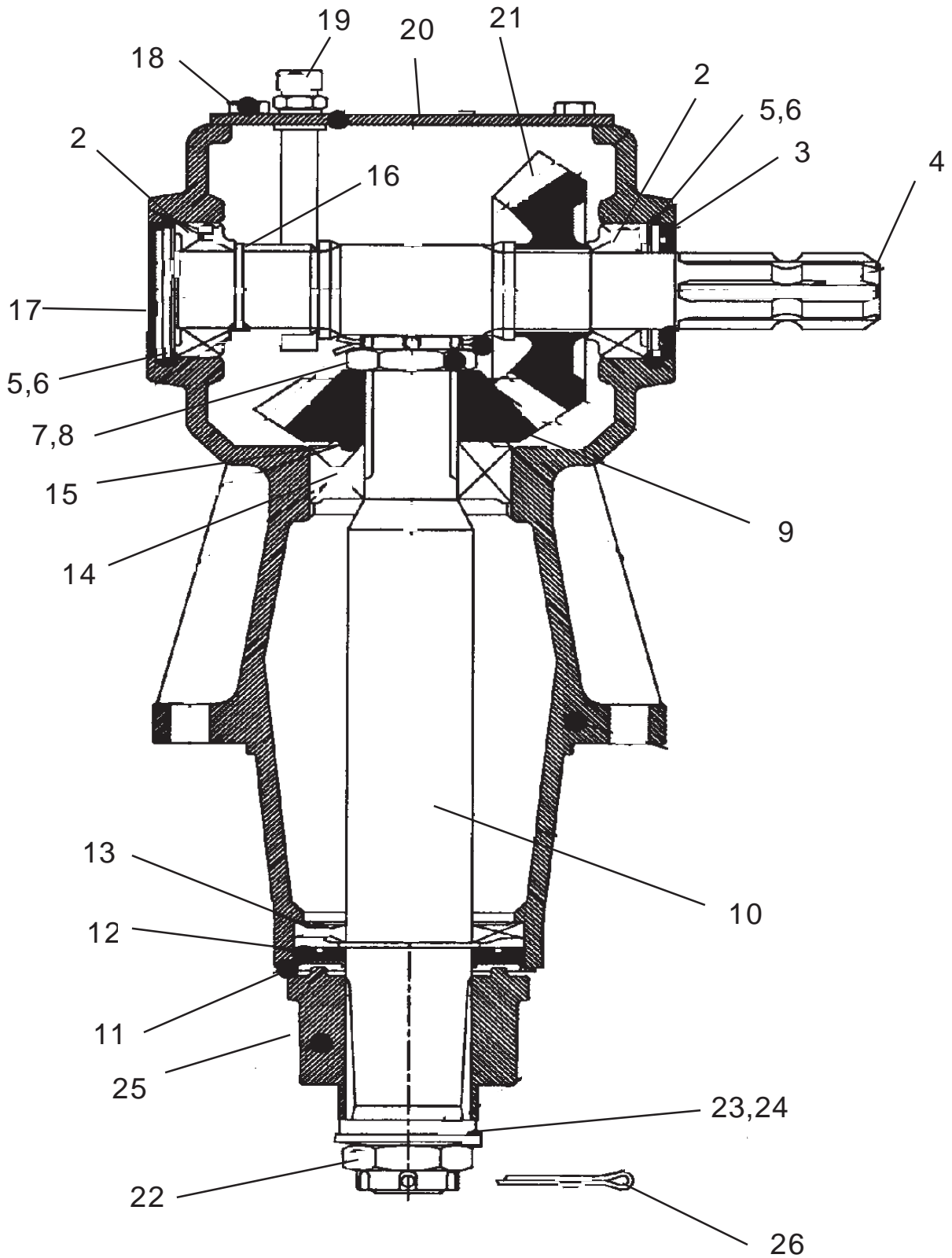

Gearbox

P/N 02978533

Item	Part No.	Qty.	Description
	02978533	-	Gearbox Asy, (540 or 1000 RPM)
1	02978747	1	Casing
2	02978748	2	Bearing
3	02978733	1	Oil seal
4	02978749	1	Input shaft
5	02978750	2	Snap ring
6	02978751	2	Shim
7	02978752	1	Cotter pin
8	02978753	1	Nut
9	02978772	1	Gear, (540 or 1000 RPM)
10	02978758	1	Shaft, Input
11	02978755	1	Seal Protector
12	02978756	1	Oil seal
13	02978757	1	Bearing
14	02978759	1	Bearing
15	02978760	1	Shim
16	02978761	1	Shim
17	02978762	1	Cap
18	02978763	4	Bolt
19	02978764	1	Plug
20	02978765	1	Cover
21	02978773	1	Gear, (540 or 1000 RPM)
22	02978767	1	Castle nut
23	02978768	1	Flat washer
24	02978769	1	Washer, disc spring
25	02978770	1	Splined hub (Welded to Blade Carrier)
26	02978771	1	Cotter pin

Gearbox

P/N 02978533

Assembly Instructions

Installation Part Numbers are for Gearbox #002978533 (540 or 1000 RPM)

1. **Installing Output Shaft** (Blade Shaft), Bearings, Gear in Main Housing (Item 1) using same amount of Shims removed & adding or deleting to adjust.
2. Install Upper Bearing Cup (item 14) into Main Housing (item 1) from the top, Install Lower Bearing Cup (Item 13) into Main housing from the bottom.
3. Install the Lower Bearing Cone (item 13) down over Output Shaft (item 10). Insert Output Shaft with Bearing Cone on it up through Main Housing from the bottom. Put Upper Bearing Cone (item 14) over Output Shaft and slide down till it bottoms out in upper Bearing Cup.
4. Install Shims (item 15) down over top of Output Shaft, The number of shims required will vary, try to use the same amount as were removed. Install Output Gear (item 9) over Output Shaft, Make sure it is seated against Shim. Screw Slotted Bearing Adjusting Nut (item 8) onto top of Output Shaft.
5. Tighten Bearing Adjusting Nut above Gear till Bearings have 14" to 16" pounds of rolling Torque, Tap Shaft using a coated Hammer or a Brass Drift pin to insure Bearings are seated straight then recheck Bearing rolling Torque. Secure Bearing Adjusting Nut with Cotter Pin and bend it over.
6. DO NOT Install Output Seal (item 12) or Seal Protector (item 11) now, wait till Input Shaft has been installed, When you do install it Coat ID of Seal with light coat of grease. Install Seal Protector (Item 11), this drives into lower Main Housing, This Seal Protector Should always be replaced with new one after being removed. Re-Check Bearing Pre-load. Output Shaft Should have NO end play and Bearing MUST be set at a rolling Torque. (See Step 5.)
7. **Installing Input Shaft**, Bearings and Gear into Main Housing (item 1) using same amount of Shims as were removed and adding or deleting to adjust. in Step 8 below the procedure is for a gear in the front, when install where gear is in the back shaft is installed from the front of main housing.
8. Holding Gear (item 21) in Gearbox Housing from top opening, Slide Input Shaft through back side of Main Housing (item 1) and through input Gear (item 21) till shaft sticks out the front of Main Housing. Slide Shims (item 16) on Shaft till they seat against Gear. Slide Front Input Bearing Cone (item 2) with smaller end pointing out onto front of input shaft till it seats against Shims (item 16). Slide Front Bearing Cup (item 2) onto front of input shaft and into Main Housing till it is seated against Bearing Cone. Install Shims (item 6) into front of main housing till they are against Bearing Cup. Install Snap ring (item 5). DO NOT INSTALL ANY SEALS YET
9. Install Shims (item 16) onto rear of Input Shaft and install Rear Input Bearing Cone (item 2) into Rear of Main Housing till it is against Shoulder on Shaft, Install Bearing Cup (item 2) into rear of main housing, Install Shims (item 6) in against Bearing Cup try to use the same amount of shims as were removed. Install Internal Clip (item 5) into Main Housing against Shims. DO NOT install any Seals at this time. Check Bearing Preload now, it should be 14" to 16" lbs of rolling Torque, remove or add Shims (item 6) to adjust.

Gearbox

P/N 02978533

Assembly Instructions

10. Check Gear Back-Lash between Blade Shaft Gear and Input Gear (should have .017" to .019" back Lash) If it is not correct, moving shims (item 6) on Input Shaft Bearings from front to back or vice versa will change Bearing Back lash (Note moving Shims from front to back will not change Bearing Preload BUT removing or adding them will), It may be required to add or remove shims from Blade Shaft output Gear to raise or lower it to get correct Back-lash. Once all is correct Coat all Seal ID with light coat of grease. Install Input Seal (3) and Rear Seal Cap (item 17) then recheck Gear and Bearing settings. Now is the time to install Output seal (item 12) and lower seal protector (item 11),
11. Install Top Cover (item 20) now using a good quality of Form-a-gasket material, or fill Gearbox with Oil (see step 12) then install Topcover, Install Vent Plug / Dip Stick (item 19) in to top Cover.
12. When this has been Done fill Gearbox with Oil, Before deciding Gearbox is full wait long enough for Oil to run down between Output Shaft Bearing, Then refill with Oil, install Top Cover (using Sealer for Gasket), Oil Plugs and check for leaks, After running Mower 1/2 to 1 hour check Oil Level and recheck for leaks.

NOTE: The Following Gearboxes will assemble the same as the above with very minor differences, some componet numbers and the location of the Input gear.

Gear Box #	RPM	Input Gear
02978513.....	540 rpm.....	Front
02978523*	540 rpm.....	Rear
02978971.....	1000 rpm.....	Front
02978533.....	1000 rpm.....	Front
02978523*	1000 rpm.....	Rear

* 02978523 used same gearbox as 540 or 1000 ratio changed through the Divider Gearbox on Flex Wing Cutter.

GEARBOX P/N 02978968

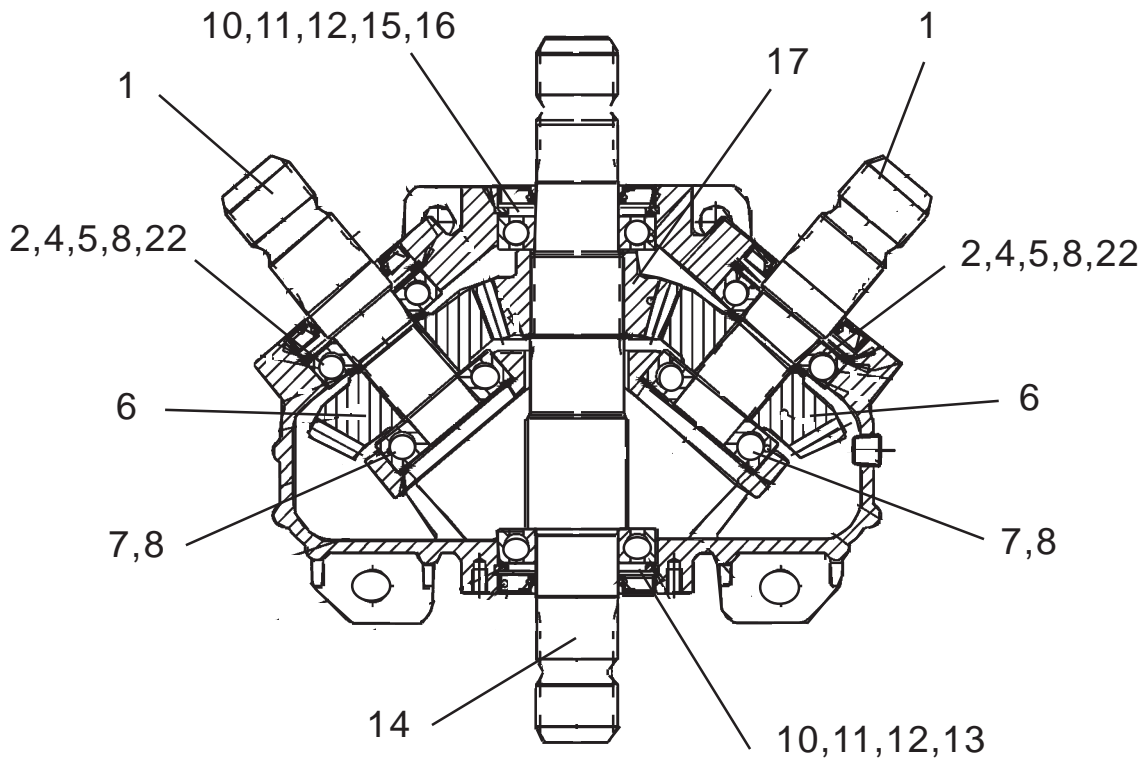
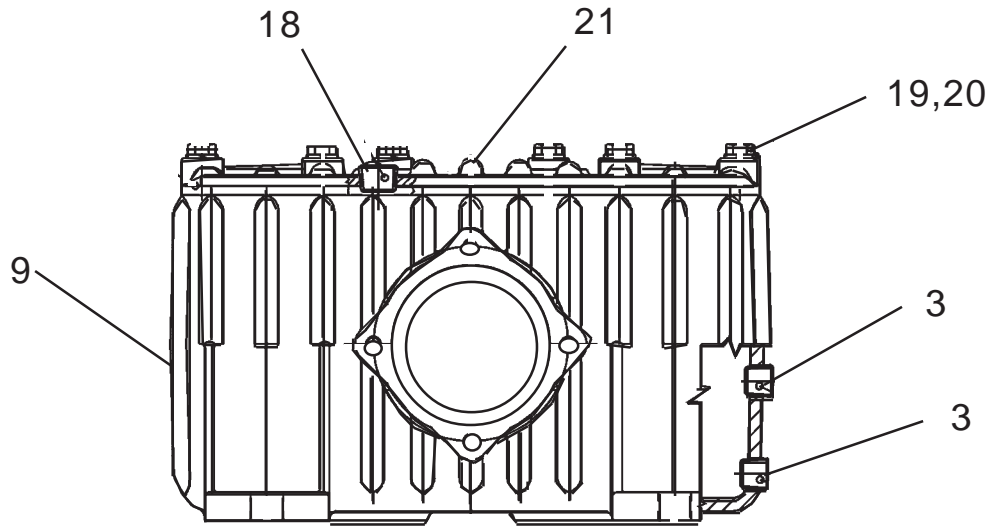

GEARBOX

P/N 02978968

Item	Part No.	Qty.	Description
	02978968	--	Gearbox Asy. (1000 RPM)
1	02978732	2	Shaft 1-3/4" X 20 Spline
2	02978733	2	Oil Seal
3	02978731	2	Plug
4	02978735	2	Snap Ring
5	02978734	2	Bearing
6	02978969	2	Gear, (1000 RPM)
7	02978734	2	Bearing
8	02978737	2	Shim Kit
9	02978738	1	Casing
10	02978739	2	Snap Ring Lining
11	02978740	2	Oil Seal
12	02978741	2	Shim
13	02978742	1	Bearing
14	02978743	1	Shaft 1-3/4" X 20 Spline
15	02978744	1	Snap Ring
16	02978742	1	Bearing
17	02978970	1	Gear, (1000 RPM)
18	02978727	1	Plug
19	02978730	6	Spring Washer
20	02978729	6	Bolt
21	02978728	1	Cover, Top
22	000944	4	Lock Nut, (f/mounting Gearbox)
23	00753753	4	Bolt, (f/mounting Gearbox0

GEARBOX

P/N 02978968

Assembly Instructions

Installation Part Numbers are for Gearbox #002978968 (1000 RPM)

- 1. Install Center Input / Output Shaft** (item 14) , with Bearings, Gear and components as shown in Drawing into Main Housing (Item 9), install Input shaft before installing Output Shafts to Wings, Notice Item 12, these are Shim Washers (Compensating Rings) to keep end play out of Shaft. there may be one ore more used. **DO NOT INSTALL ANY SEALS TILL GEARBOX IS COMPLETELY ASSEMBLED !** Before you install the seals check the openings for burrs or scratches that will damage or prevent the OD of the seal from sealing. Remove any Burrs and fill scratch with good gasket Sealer
- 2. Install Snap Ring** (Item 10) in Back of Housing (Item 9), this will retain Rear bearing (item 16) **DO NOT** install Rear Seal (item 11) at this time. Install Front Shims (item 12), Qty use same as was removed as this amount can vary. Slide rear Bearing (item 16) into housing (item 9) this can be done from inside. Push Bearing in till it seats against the Shims & Snap Ring (items 10 & 12).
- 3. Holding Input Gear** (item 17) into Gearbox Housing (item 9) from the top slide the Input Shaft (item 14) into the Housing from the front. Slide Shaft through Gear and Rear Bearing.
- 4. Install Front Bearing** (item 13) on input Shaft from the front. Slide Bearing till it goes into Geabox Housing and seats against Shoulder on Input Shaft. Install Shims (item 12) using quantity that will will allow end play to be removed, This is a trial & error method because you will need to install Snap Ring (item 10) to check then remove it to add or remove Shims. These are ball Bearings so they will not have Pre-Load. **DO NOT** install Front Seal (item 11) at this time.
- 5. Install Output Shaft to Side Drives**, The Left & Right Shafts will install the Same using the same Part Numbers. it is best to install Parts for both Side Drive Shafts at same time.
- 6. Looking down into gearbox Housing** (item 9) you can see the inner casting for the Inner Bearing (item 7), There will be adjusting Shims (item 8) that need to be installed here before Bearing is. The quantity of Shims will vary, Try the same amount as was removed here. Install the inner Bearing (item 7) into Housing.
- 7. Side Output Shaft** (item 1) has a Snap Ring Grove on it near outer Bearing (item 5)area. Slide Outer Bearing (item 5) onto Side Shaft (item 1) till it seats against Shoulder on Shaft. Install Snap Ring (item 22) on Shaft next to Bearing.
- 8. Take the Gear for Side Drive** (item 6) and slide it down into Gearbox from the Top, With the side Drive Gear in position against the Input Gear (item 17), take the Side drive Shaft (item 1) and Slide it through the Housing from the out side, rotating Shaft as you push it through to align Splines on shaft with spline in Gear. Push the Shaft in till the Bearing is into Housing and the shoulder on Shaft seats against inner Bearing.

GEARBOX

P/N 02978968

Assembly Instructions

- 9.** From the outside install Shims in against Outer Bearing, use quantity to remove end play, install Snap Ring (item 4) to retain Components of Side Out put Shaft. **DO NOT** install Seals at this time.
- 10.** it is now time to check Gear Back-Lash and Seating of gears Heal to Toe, The Back-Lash and Seating of gears can be changed by moving Shims (item 12) on center Shaft and (item 8) on Side Drive Shafts. this is a trial & error Method of adding & removing Shims. Do This till the Gear Back Lash is .016" to .019" and Gear seating is even Heal to Toe.
- 11.** Coat all Shafts & ID of seals with a light coat of Grease before installing Seals. Install Seals Now, if the openings for the seals have not been inspected as explained in Step 1, do so now before installing Seals.
- 12.** Install top cover using Gasket sealer, Fill Gearbox with oil. Gearbox can be filled with oil before top cover is installed if wanted. **DO NOT** Fill with Oil above Oil Level Plug. Always check for Oil Leaks before Running Mower and Always recheck Oil Level, Inspect Seals for Leaking, Excessive end play in Shaft after running Mower 1/2 to 1 hour

GEARBOX P/N 4800

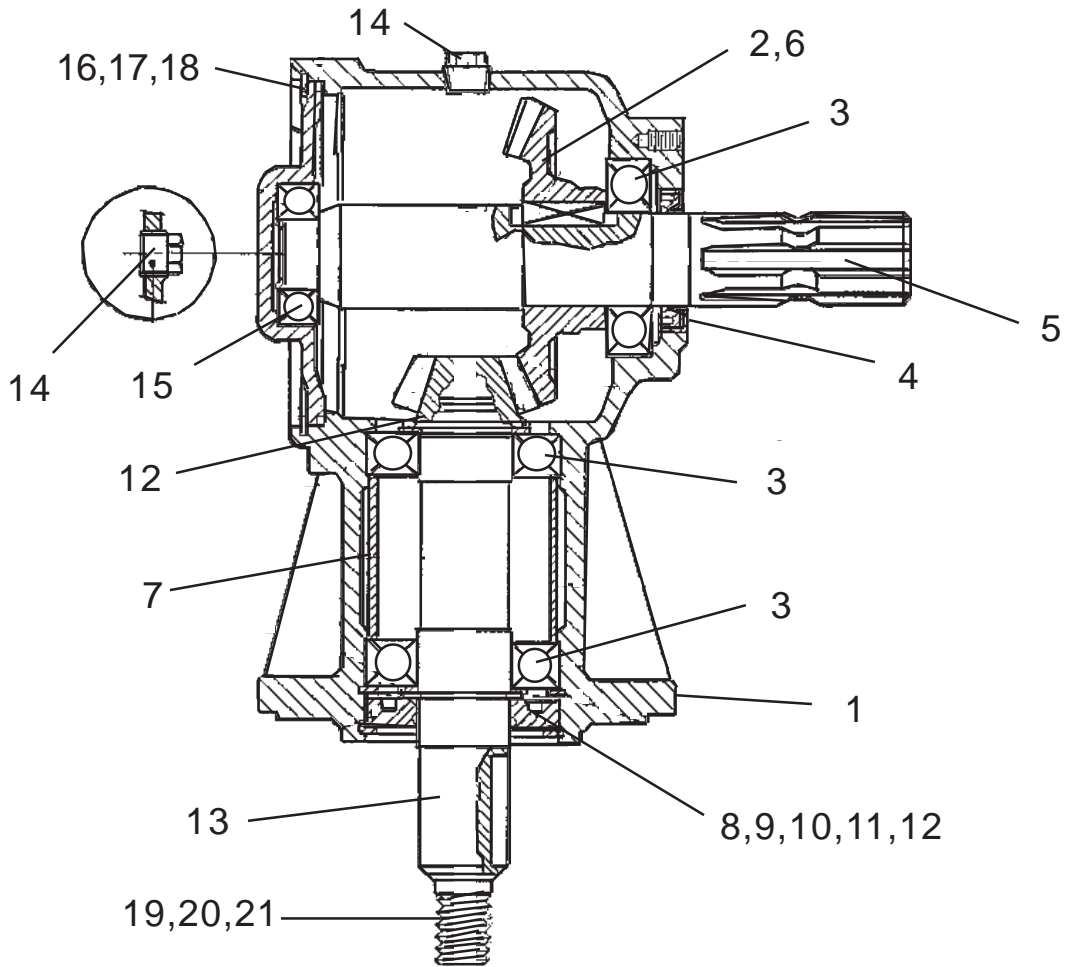

Item	Part No.	Qty	Description	Item	Part No.	Qty	Description
	4800	--	Gearbox Asy, (540 RPM)	11	4848	1	Seal, Dust Shield
1	4829	1	Casing	12	4849	2	Shim
2	4832	1	Key	13	4850	1	Output Shaft (12 teeth)
3	4833	3	Bearing	14	4851	2	Plug
4	4834	1	Oil Seal	15	4852	1	Bearing
5	4835	1	Input Shaft	16	4853	1	Cover
6	4836	1	Crown Gear (30 teeth)	17	4855	1	Shoulder Ring
7	4837	1	Spacer	18	4857	1	O-Ring
8	4838	1	Internal Clip	19	4840	1	Nut Slotted (Not Shown)
9	4839	1	External Clip	20	4846	1	Washer (Not Shown)
10	4847	1	Shoulder Ring	21	7343	1	Cotter Pin (Not Shown)

GEARBOX

P/N 4800

Assembly Instructions

- 1. Installing Input Shaft and Gear,** Install Front Bearing (item 3) into Main Housing (item 1) Bearing will install from back side of Housing.
- Install Key (item 2) into Input Shaft, Slide input Gear (item 6) on to Shaft from front Side.
- Install Input Seal into Main Housing from the Out Side or Seal can be installed later if wanted, If Seal is installed coat ID of Seal with light coat of Grease and also coat area on Shaft where Seal contacts Shaft.
- Drop Input Shaft with Gear on it through Seal and Main Housing from the Back of Main Housing. Use caution not to damage Input Seal if it has been installed
- Insert Rear Cover O-Ring (item 18) into Housing and coat it with a light coat of grease. Push Rear Cover (item 16) into Housing, Cover is held in place by Shoulder Ring (item 17) which is installed now.
- 6. Installing Output Shaft** (item 13) , with Bearings and componts as shown in Drawing into Main Housing (Item 1), install Input shaft before installing Output Shaft
- Install components onto Output Shaft (item 13), First slide the Shims (item 12) at top of Output Shaft under Gear on use the same quantity as was removed, Install Top Bearing (item 3) on till it seats against Shims.
- Slide Lower Bearing Spacer (item 7) on Output Shaft, This Spacer has the OD same as the Bearings so it will be loose on Shaft. Put Lower Bearing (item 3) on Shaft til it seats against Bearing Spacer.
- Install more Shims (item 12) on output shaft, Use same Quantity as was taken off. Install the External Snap ring (item 9) onto Output Shaft.
- The Out out Shaft, Bearings, Shims, Bearing Spacer and Snap Ring should be all one assembly now. Slide this assembly up into Main Housing from the Bottom, It may be required to move Bearing spacer side to side to keep it lined up. Slide assembly in till upper Bearing bottoms out in Housing.
- Install Lower Internal Snap Ring (item 8) into lower end of Main Housing, This retains Output Shaft and components. DO NOT install lower Seal at this Time.
- Check Shaft for end Play and Gear Back-Lash, there should be no end play, If there is install more Shims (item 12) on Shaft, If Shaft is to tight use less Shims. Gear Back-Lash should be .016" to .019" if it is not then move Shims (item 12) from Top to Bottom or Bottom to Top, Where ever they are moved from they will have to go to the other end to keep End Play correct.
- Install Lower Seal (Item 11 Dust Shield), Coat Seal ID with light coat of grease, Install Shoulder Ring (item 10)
- Fill Gearbox with oil. DO NOT Fill with Oil above Oil Level Plug. Wait a while let Gearbox sit and have time for Oil to run down into lower Bearings and recheck Oil Level. ALWAYS recheck Oil Level after running Mower 1/2 to 1 hour. Inspect Seals for leaking after filling with Oil and after running 1/2 to 1 hour.

GEARBOX P/N 4800

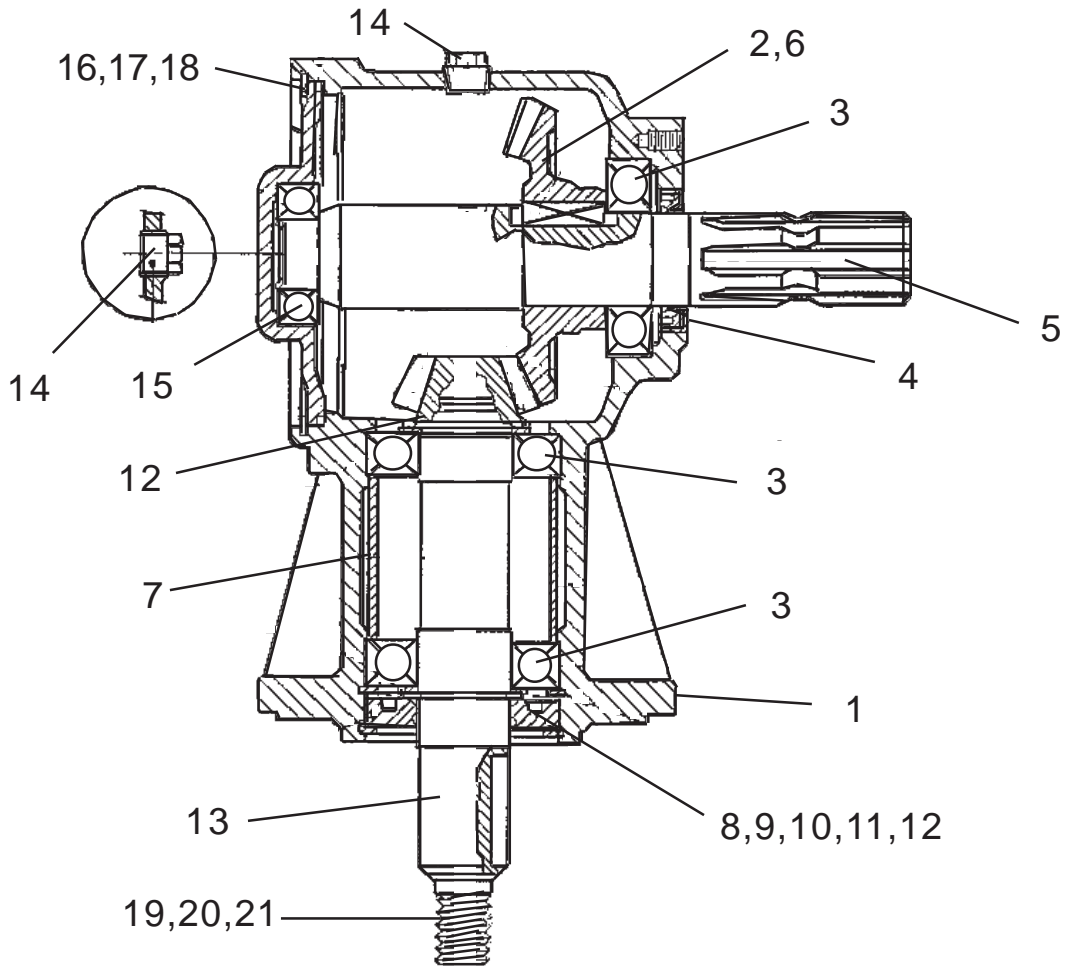

Item	Part No.	Qty	Description	Item	Part No.	Qty	Description
	4800	--	Gearbox Asy, (540 RPM)	11	4848	1	Seal, Dust Shield
1	4829	1	Casing	12	4849	2	Shim
2	4832	1	Key	13	4850	1	Output Shaft (12 teeth)
3	4833	3	Bearing	14	4851	2	Plug
4	4834	1	Oil Seal	15	4852	1	Bearing
5	4835	1	Input Shaft	16	4853	1	Cover
6	4836	1	Crown Gear (30 teeth)	17	4855	1	Shoulder Ring
7	4837	1	Spacer	18	4857	1	O-Ring
8	4838	1	Internal Clip	19	4840	1	Nut Slotted (Not Shown)
9	4839	1	External Clip	20	4846	1	Washer (Not Shown)
10	4847	1	Shoulder Ring	21	7343	1	Cotter Pin (Not Shown)

GEARBOX

P/N 4800

Assembly Instructions

- 1. Installing Input Shaft and Gear,** Install Front Bearing (item 3) into Main Housing (item 1) Bearing will install from back side of Housing.
2. Install Key (item 2) into Input Shaft, Slide input Gear (item 6) on to Shaft from front Side.
3. Install Input Seal into Main Housing from the Out Side or Seal can be installed later if wanted, If Seal is installed coat ID of Seal with light coat of Grease and also coat area on Shaft where Seal contacts Shaft.
4. Drop Input Shaft with Gear on it through Seal and Main Housing from the Back of Main Housing. Use caution not to damage Input Seal if it has been installed
5. Insert Rear Cover O-Ring (item 18) into Housing and coat it with a light coat of grease. Push Rear Cover (item 16) into Housing, Cover is held in place by Shoulder Ring (item 17) which is installed now.
- 6. Installing Output Shaft** (item 13) , with Bearings and componts as shown in Drawing into Main Housing (Item 1), install Input shaft before installing Output Shaft
7. Install components onto Output Shaft (item 13), First slide the Shims (item 12) at top of Output Shaft under Gear on use the same quantity as was removed, Install Top Bearing (item 3) on till it seats against Shims.
8. Slide Lower Bearing Spacer (item 7) on Output Shaft, This Spacer has the OD same as the Bearings so it will be loose on Shaft. Put Lower Bearing (item 3) on Shaft til it seats against Bearing Spacer.
9. Install more Shims (item 12) on output shaft, Use same Quantity as was taken off. Install the External Snap ring (item 9) onto Output Shaft.
10. The Out out Shaft, Bearings, Shims, Bearing Spacer and Snap Ring should be all one assembly now. Slide this assembly up into Main Housing from the Bottom, It may be rquired to move Bearing spacer side to side to keep it lined up. Slide assembly in till upper Bearing bottoms out in Housing.
11. Install Lower Internal Snap Ring (item 8) into lower end of Main Housing, This retains Output Shaft and components. DO NOT install lower Seal at this Time.
12. Check Shaft for end Play and Gear Back-Lash, there should be no end play, If there is install more Shims (item 12) on Shaft, If Shaft is to tight use less Shims. Gear Back-Lash should be .016" to .019" if it is not then move Shims (item 12) from Top to Bottom or Bottom to Top, Where ever they are moved from they will have to go to the other end to keep End Play correct.
13. Install Lower Seal (Item 11 Dust Shield), Coat Seal ID with light coat of grease, Install Shoulder Ring (item 10)
14. Fill Gearbox with oil. DO NOT Fill with Oil above Oil Level Plug. Wait a while let Gearbox sit and have time for Oil to run down into lower Bearings and recheck Oil Level. ALWAYS recheck Oil Level after running Mower 1/2 to 1 hour. Inspect Seals for leaking after filling with Oil and after running 1/2 to 1 hour.

GEARBOX P/N 700493

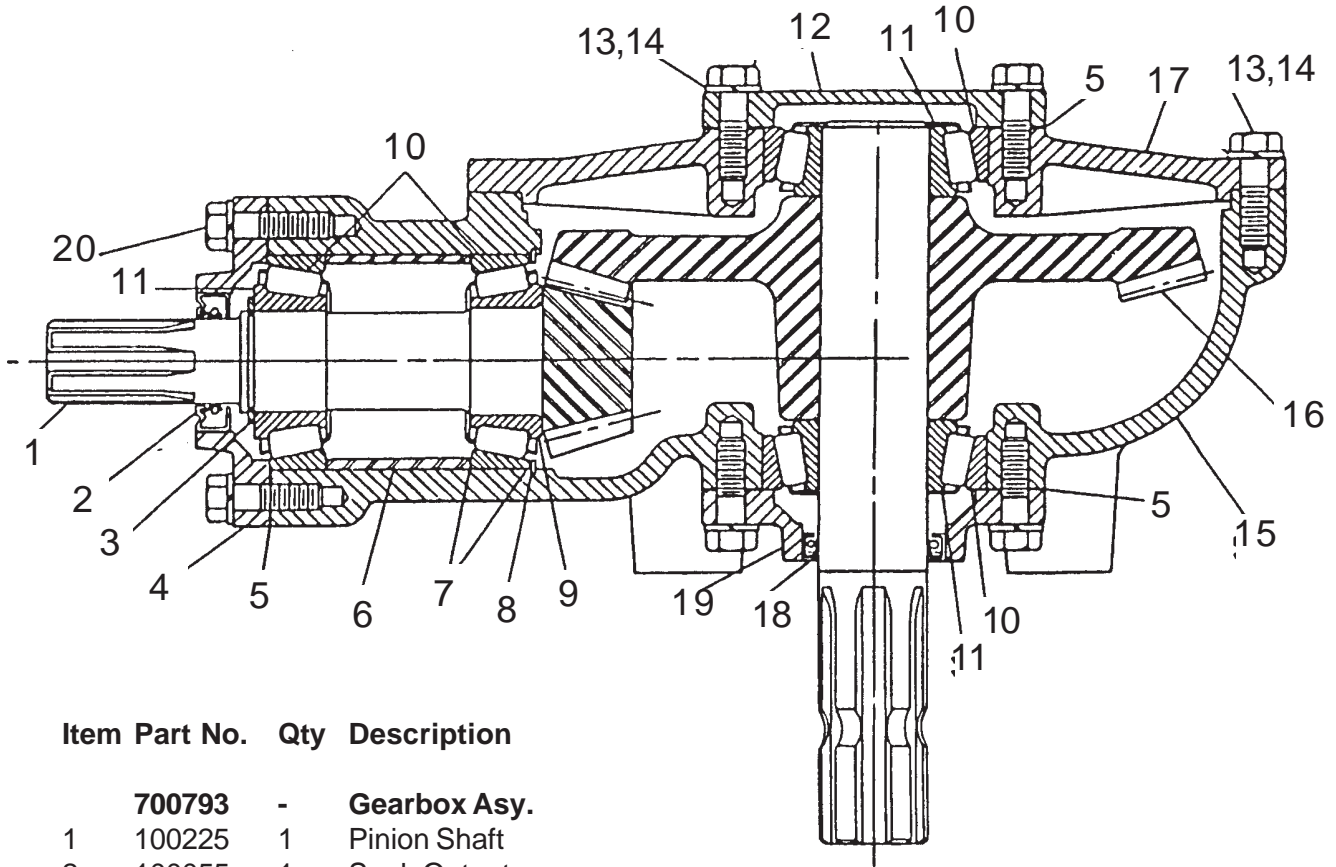

Item	Part No.	Qty	Description
	700793	-	Gearbox Asy.
1	100225	1	Pinion Shaft
2	100055	1	Seal, Output
3	000330	1	Retaining Ring
4	100707	1	Seal Housing
5	100232	a/r	Shim (.020")
	100233	a/r	Shim (.007")
	100234	a/r	Shim (.005")
	100235	a/r	Shim (.002")
6	100241	1	Spacer
7	100237	a/r	Shim (.002")
	100238	a/r	Shim (.004")
	100239	a/r	Shim (.006")
	100240	a/r	Shim (.020")
8	000331	1	Retainer Ring
9	000329	1	Bearing, Cone
10	000327	4	Bearing, Cup

Item	Part No.	Qty	Description
11	000328	3	Bearing, Cone
12	100231	1	Bearing Cap
13	000354	16	Bolt
14	000019	20	Lockwasher
15	100228	1	Gear Housing
16	700495	1	Shaft & Gear Asy
17	100229	1	Housing Cover
18	100054	1	Seal, Input
19	100230	1	Seal Housing
20	000601	4	Bolt
21	000054	1	Pipe Plug, Level (1/2")
22	000055	1	Pipe Plug, Fill (1/4")

NOTE: This G/B Asy (P/N 700493) is replaced by later style (P/N 702673) as an Asy. Parts WILL NOT interchange between them. The easiest way to tell which G/B you have is by looking where the Shaft goes through the G/B Housing, The Old Style had Bolt on Caps Here and the new style will not.

Gearbox

P/N 700493

Assembly Instructions

Asy instructions Gearbox # 700493 (540 RPM Used Jan. 1991 & Down)

- 1. Install Output Shaft & Pinion Gear** into Main Housing (# 100228)
- 2.** Install Snap Ring (# 000331) into Main Housing (#100228). Install Inner Output Bearing Cone (#000329) on Output Shaft (#100225). Install Inner Bearing Cup (#000327) down over Bearing Cone, Make Note of Shims (#100236 = .002", #100237 = .004", #100238 = .006", #100239 = .012" & #100240 = .020") quantity will be as required, try to put in the same amount as taken out. These shims will be on either side of Inner Output Shaft Bearing Cup. Slide out put shaft into housing with Inner Bearing Cup with Shims. Slide Bearing Spacer (#100241) in till it bottoms out against inner Bearing Cup, Insert Outer Bearing Cup (#000327) into Main Housing, Slide Outer Bearing Cone (#000328) over Shaft till it seats against Outer Cup (#000327). Install Snap Ring (#000330) onto output shaft next to outer Bearing Cup.
- 3.** Install Output Seal (#100055) into Seal Housing (#100707), Install Seal Housing using Shims (#100232 = .020"), (#10233 = .007"), (#100234 = .005"), (#100235 = .002") quantity as required onto Main Housing over Output Shaft. Tighten Bolts (#000601) and check Bearing Pre-Load, Should be from 14" to 16" pounds of rolling torque. Shaft should NOT have end play, If you have end play it will be required to rearrange shims at Inner Bearing Cup or at Bearing cover till settings are right.
- 4. Install Input Shaft & Gear** into Main Housing:
- 5.** Install front Bearing Cone (#000328) and rear Bearing Cone (#000328) onto Input Shaft and Gear Asy. (#700492) Gear & Shaft can only be replaced as an Assembly, Gear cannot be pressed off of Shaft. Install Input Seal (#100054) into Input Bearing Cover (#100230), Install outer Bearing Cup (#000327) into Main Housing. Using Shims (#100232 = .020"), (#100233 = .007"), (#100234 = .005"), (#100235 = .002") quantity as required (try same quantity as taken off) install Input Bearing Cover on front of Main Housing tightening 4 retaining bolts.
- 6.** Install Rear Housing Cover (#100229) on rear of Main Housing, Use Gasket Sealer on this cover it will not use a Gasket, If a Gasket is wanted Gasket # 00769800 can be used. Install Rear Bearing Cup (#000327) into rear Housing Cover. Using Shims (#100232 = .020", #100233 = .007", #100234 = .005" & #100235 = .002") quantity as required (try same quantity as taken off) install Rear Bearing Cap (#100231) on Rear Housing Cover, tightening 4 retaining bolts. This will set Bearing Pre-Load, It should be at 14" to 16" pounds of rolling torque. It may be required to remove shims from Bearing Caps or add Shims.
- 7.** Set Gear Back Lash with Bearing Cap Shims, Gear Back Lash should be from .014" to .017", This is very critical. By moving shims from front cover to back cover or vice versa gear is moved inward or outward, DO NOT add or delete shims as this will change your Bearing Pre-Load.
- 8.** Fill Gearbox with Oil till Oil flows out of Oil Level hole. Install Oil Level Plug (#000054) and Oil Fill Plug (#000055). Check all Seals and Gasket areas for leaks. After Running Mower 1/2 to 1 hour recheck Oil Level and check for any leaks.

HELP !

There were TWO GEARBOXES used that looked very much the same but they are not, The earlier model (#700493) till approx Jan. 1991 , this gearbox can be identified by the round 4 bolt cover at the input shaft and small 4 bolt round cover in the middle of the larger 8 bolt cover in the rear, There is a 4 bolt cover at the Output Shaft also. These covers are to adjust the Bearing preload and Gear backlash. This gearbox will also have Roller Bearings on Input Shaft and Output Shaft. The Later Type (# 702673) Feb 1991 & up has Ball Bearings on Input shaft and will replace the # 700493 G/B as an assembly, Parts WILL NOT interchange between these two gearboxes.

GEARBOX P/N 702673

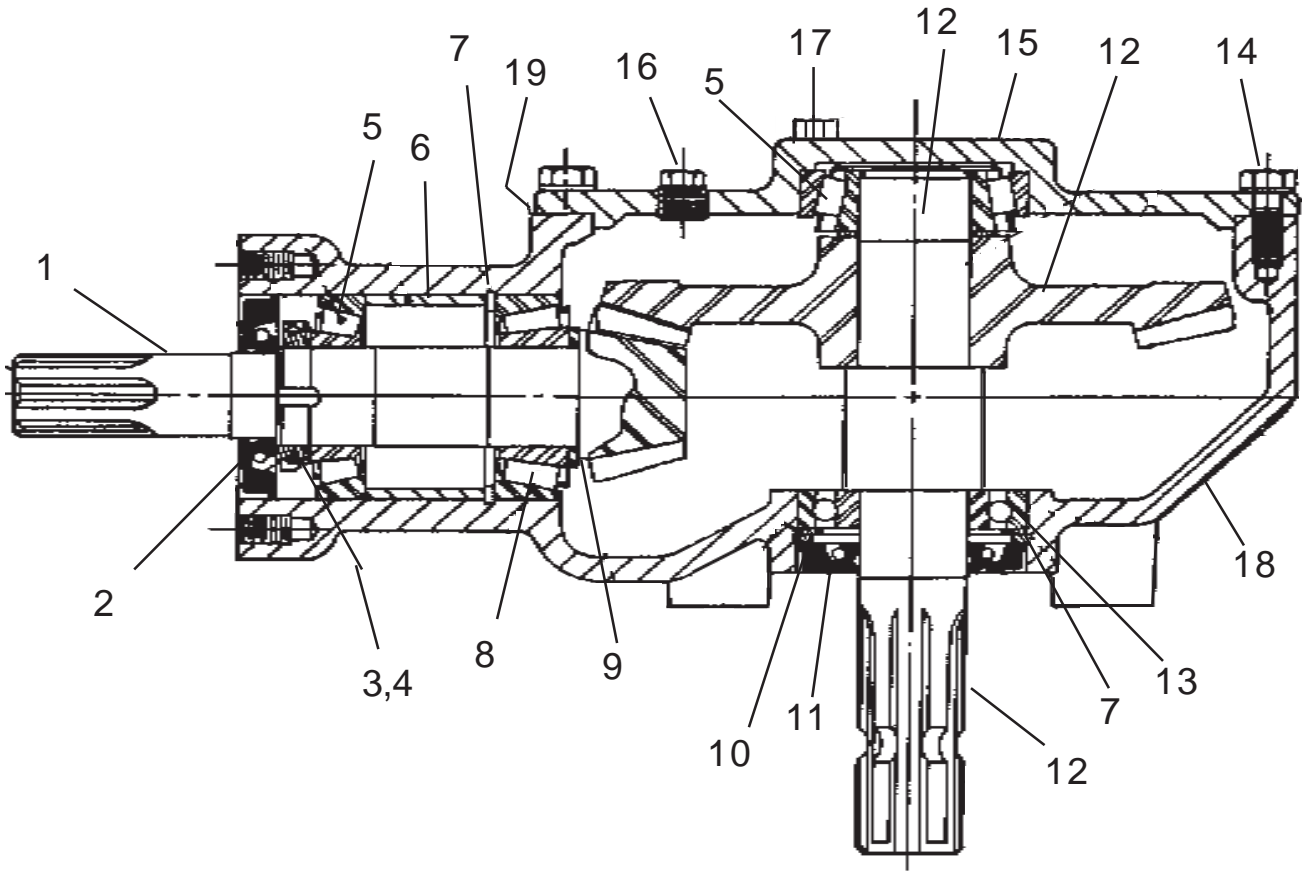

Item	Part No.	Qty	Description
	702673	-	Gearbox Asy.
1	001718	1	Pinion
2	001719	1	Seal
3	001717	1	Nut
4	001720	1	Spring Washer
5	00754757	2	Bearing, Roller
6	001716	1	Spacer
7	00754752	2	Circlip, Internal
8	001722	1	Bearing, Roller
9	00753222	2	Shim
10	00754761	1	Shim

Item	Part No.	Qty	Description
11	001724	1	Seal
12	001725	1	Shaft & Gear
13	00754459	1	Bearing, Ball
14	001708	8	Bolt
15	001710	1	Cover
16	00755633	2	Plug
17	000055	2	Plug, Drain
18	002516	1	Housing
19*	00769800	1	Gasket (See * NOTE:)

* NOTE: Some Models Used Gaskets. Currently All Models Use Sealant, or Form - A - Gasket.

NOTE: This G/B Asy (P/N 702673) Can replace earlier style (P/N 700493) as an Asy but parts WILL NOT interchange between them. The easiest way to tell which G/B you have is by looking were the Shaft goes through the G/B Housing, The Old Style had Bolt on Caps Here and the new style will not.

G/B Repair Manual07/02

Gearbox P/N 702673 Assembly Instructions

Assembly Instructions Gearbox # 702673 (Used Feb. 1991 & Up)

1. **Install Output Shaft & Pinion Gear** into Main Housing (# 002516).
2. Install Snap Ring (# 00754752) into Main Housing (#002516). Install Shims (#00753222) on Output Shaft next to Gear. Install Inner Output Bearing Cone (#001722 Cup & Cone) on Output Shaft (#001718). Install Inner Bearing Cup (#001722 Cup & Cone) down over Bearing Cone, Slide output shaft into housing. Insert Snap Ring (#00754752) into Main Housing. Slide Bearing Spacer (#001716) in till it bottoms out against Snap Ring.
3. Insert Outer Bearing Cup (#00754757 Cup & Cone) into Main Housing till it is against Bearing Spacer, Slide Outer Bearing Cone (#00754757 Cup & Cone) over Shaft till it seats against Outer Cup. Install Tabbed Lock Washer (#001720) onto output shaft next to outer Bearing Cone, Make sure Inner Tab of locking washer is in keyway of Shaft. Install Notched Locking Nut (#001717) by screwing it onto Output Shaft, Tighten Nut till Bearing Pre-Load is set at 14' to 16" lbs. of rolling Torque. When Bearing Pre-Load is correct, **DON'T BEND** Locking Washer Tabs into Notches on Locking Nut and **DON'T INSTALL OUTPUT SEAL AT THIS TIME**, this is important.
4. Install Input Shaft & Gear into Main Housing (# 002516)
5. Install front Bearing (#00754459) into Main Housing (#002516). Using Shims (#00754761), quantity as required (try same quantity as taken out) install Snap ring (#00754752) into Main Housing. **DO NOT INSTALL INPUT SEAL AT THIS TIME**, this is important.
6. **Install Input Shaft and Gear** Assembly (#001725) into rear of Main Housing and through front input Bearing. Install Rear Bearing Cone (#00754757 Cup & Cone) onto back of input Shaft. Install Rear Bearing Cup (#00754757 Cup & Cone) into Rear Housing Cover (#001710), make sure cup is bottomed out in Cover. Install Rear Cover using Gasket Sealer onto Main Housing and Tighten Bolts, Some rear covers may use a Gasket some sealed with Sealer, If Gasket wanted Gasket # 00769800 will fit and can be used for rear cover.
7. Set Bearing Pre-load on Input Shaft to remove end Play Only, this is because outer Bearing is a Ball Bearing. Do this by adding or removing Shims between Front input Bearing and Snap Ring.
8. Set Gear Back Lash with Shims on output shaft next to output Pinion Gear, Add or remove shims, Gear Back Lash should be from .016" to .019", This is very critical. after Gear Back Lash is correct reset Bearing Pre-Load on Output shaft.
9. Install Input Seal (#0017240 and Output Seal (#001719), Inspect all opening for seals to make sure there are no Burrs or Scratches to damage seals when installed, Always coat ID of Seals with light coat of grease this helps to prevent damage to ID of seals when being installed.
10. Fill Gearbox with Oil till Oil flows out of Oil Level hole. Install Oil Level plug and Oil Fill Plug. Check all Seals and Gasket areas for leaks. After Running Mower for 1/2 to 1 hour recheck Oil Level Looking for any leaks.

HELP !

This Later Gearbox # 702673 will only have a large 8 bolt cover on rear of gearbox without the small cover in center of it. There is a Ball bearing on front of input shaft the old style had all Roller Bearings, Input Seals are different, Older Gearbox seal is a bit larger than the later, The later type used a snap ring behind seal to hold bearings in where the earlier type had bolt on covers. If you have these bolt on covers see G/B # 700493
These gearboxes DID NOT use vent plugs at all.



**Mechanical Gearbox
Repair Manual
2002 Edition**

P/N 02979221