



A Member of Alamo Group

**BUILT SHARPER**

# Hydraulic Gear Pump and Motor Failure Analysis and Repair Guide



# Hydraulic Gear Pump and Motor Failure Analysis and Repair Guide



The heart of a hydraulic system is the hydraulic pump. The pump is the component that receives the mechanical energy supplied by the tractor or engine, and converts it to fluid energy with the use of the hydraulic oil.

A healthy pump will allow the mower system to perform at its maximum level of effectiveness. Properly maintaining the hydraulic system by changing the oil and the filters and by preventing or repairing leaks will provide hundreds of hours of trouble free operation.

The fixed displacement gear pumps utilized by Alamo Industrial are of a proven design and will easily provide exceptional service for the life of the machine. Failures of the front pump are, in fact, limited to just a few specific modes such as overheating, over-pressurization, shaft failures, contamination and cavitation. In most cases, damage to the front pump is a RESULT of a failure and not the true cause of the failure. Simply replacing the pump without understanding WHY it failed will only result in additional failures and additional expense.

Proper failure analysis of the front pump is essential to understanding why the pump failed, and thus determining the true cause of the failure. Knowing the TRUE cause of the failure will prevent additional failures.

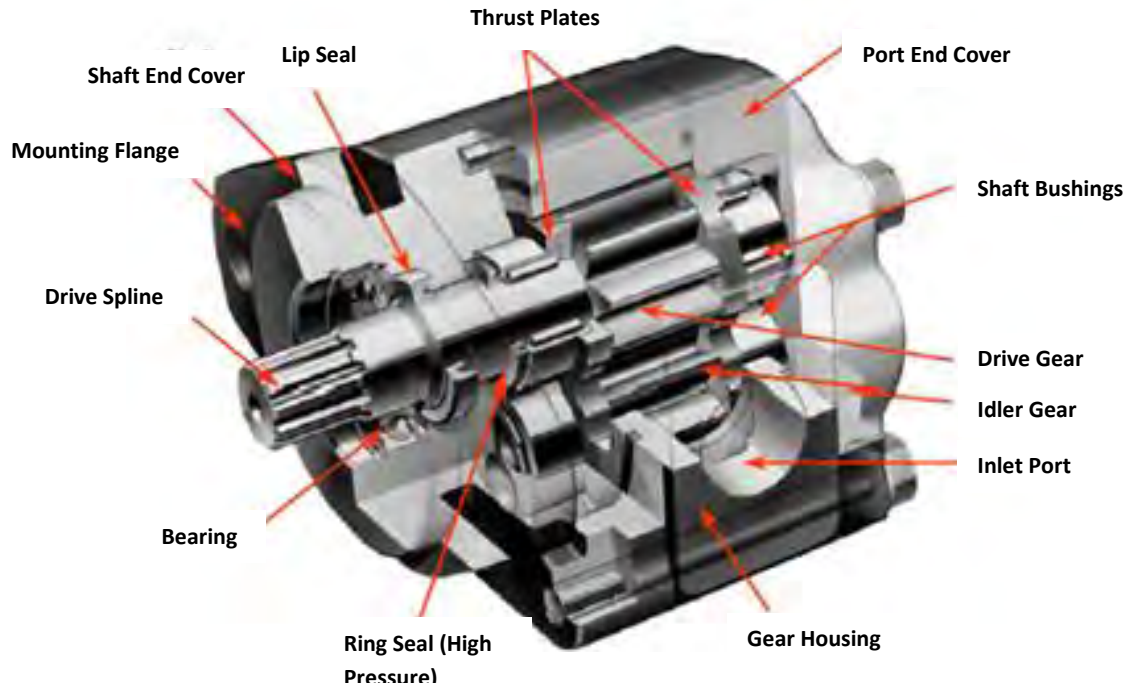

The front mounted gear pump utilizes power from the engine crankshaft to provide rotation of the pump. A flow of oil is produced by the pump due to this rotation. The amount of flow is dependent upon the size of the gears in the pump and the speed of the engine. Likewise, as the pump is rated to produce the optimum flow at the rated speed, usually 1800 to 2000rpm, the pump is described as a Fixed Displacement Pump.

(Single Pump shown above, Tandem Pump shown below)

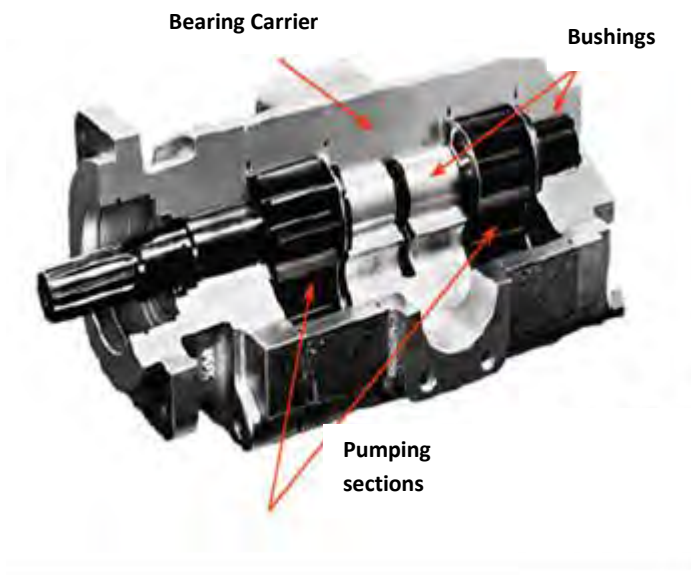

Tandem Gear Pumps may be needed when there are multiple functions that require different flows such as a requirement where tractor hydraulics for boom movement is not available. Tandem pumps operate the same as single pumps, and incorporate a bearing carrier with a driven shaft coupler to provide the operation of both pumps simultaneously.

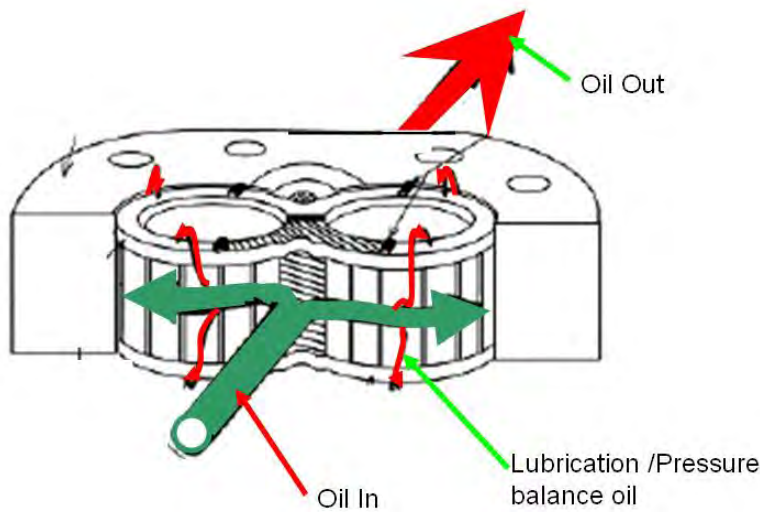

Gear pumps and motors employ a pressure balanced thrust plate design. Oil pressure hydraulically balances the thrust plates and squeezes them against the two gear faces. The squeeze provides a seal between the gear face and the thrust plate surface, preventing high pressure oil from slipping back to the low pressure side of the pump.

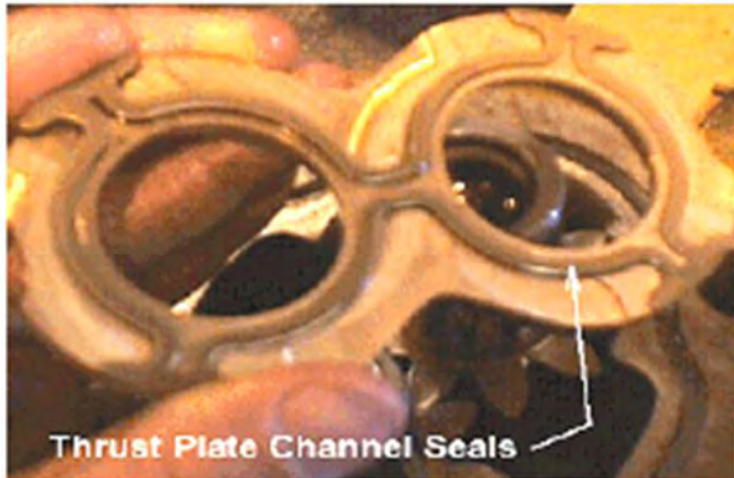

Mechanical seals and oil channel inserts are used to control the oil and block it from leaking between the plate and adjoining castings.

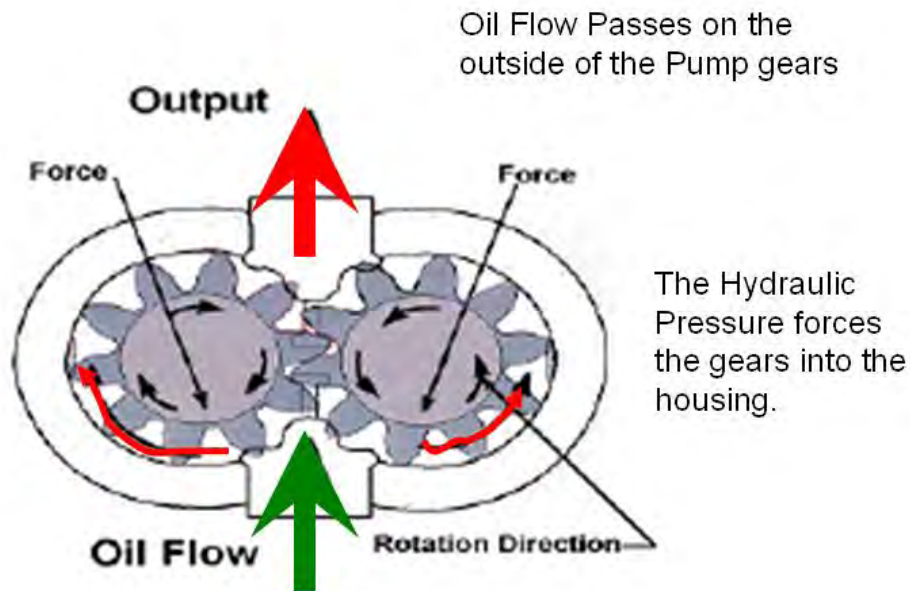

A cross sectional view of the pumping chambers illustrates the flow path of the hydraulic oil through the gear pump. As the gears counter-rotate, the separating gear teeth create a vacuum, drawing oil into the inlet. Oil is picked up by each tooth and carried around the outside of the gear. Oil is NOT drawn through the center. The pockets between the gear teeth and the housing are referred to as Pumping Chambers. As the gear teeth mesh on the outlet side, oil is forced out of the pockets and exits the pump.

The rotating action of the pump, therefore, results in a FLOW of hydraulic oil from the pump which is dependent on the size of the gear teeth and the rotational speed of the pump shaft. Resistance downstream due to hose size, adapter fittings, elbows and system valves will restrict the flow from the pump, thus resulting in pressure. High pressure on the outlet side of the housing forces the gears to deflect into the low pressure (inlet) side. The gear tips or teeth contact the housing, preventing high pressure output oil from leaking back to the low pressure side.

This contact between the gear teeth and the pump housing results in wear on the pump housing and will produce cast iron contamination into the hydraulic system, especially with new units. This inherent wear is normal and is expected but requires adherence to the maintenance schedule, especially in regard to oil and filter changes after the initial break in period.

Following the break in period, housing wear due to loading of the gears will diminish and will result in a steady state which can be maintained for an extended period. Introduction of contaminants into the system or over-pressurization of the pump, however, will result in excessive wear and eventually allow oil to leak back to the low pressure side of the pump.

## Tool List

- Arbor press
- Permanent Marker or an Awl
- Bearing puller (Owatonna Tool Co. MD-956 or equivalent)
- Clean lint free cloths
- Deburring tool (file with the cutting teeth ground off)
- Machinist's hammer
- Soft faced hammer
- Permatex Aviation Form-A-Gasket No.3 Non-hardening Sealant or equivalent
- Medium grit carborundum stone
- Hydraulic oil and grease
- Prick punch or machinists ink
- Sharp razor blade
- Scale (1/32" or 1/64" graduations)
- Feeler gauges
- Small screw driver
- Large screw drivers
- Torque wrench
- 13/16" socket
- 1/2" steel ball
- Loctite® No.262
- Vise with a 6" minimum open spread
- Lip seal installation bar (1 3/4" X 2")
- Shaft installation sleeve (steel)
- Lip seal removal tool
- Check tool
- 6" wrench

### Check Tool

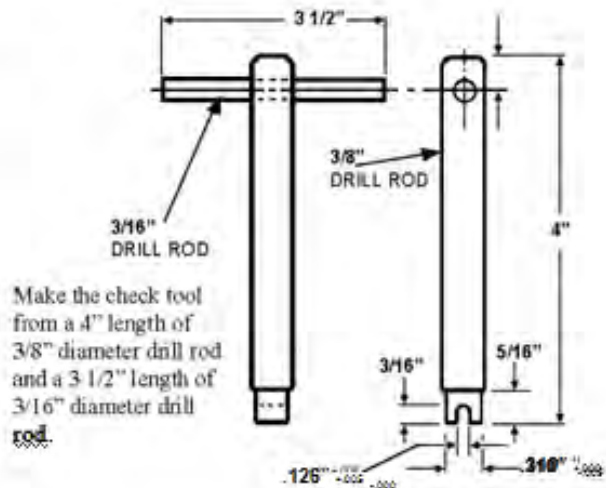

### Shaft Installation Sleeve (steel)

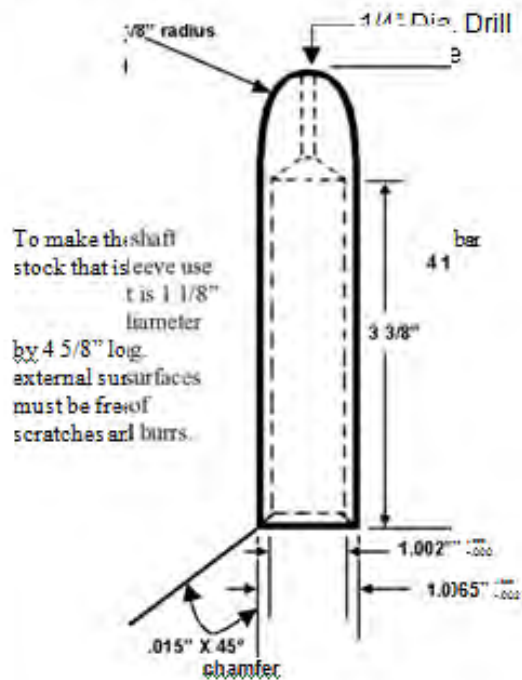

# Pump and Motor Repair Procedures: Disassembly

## STEP 1

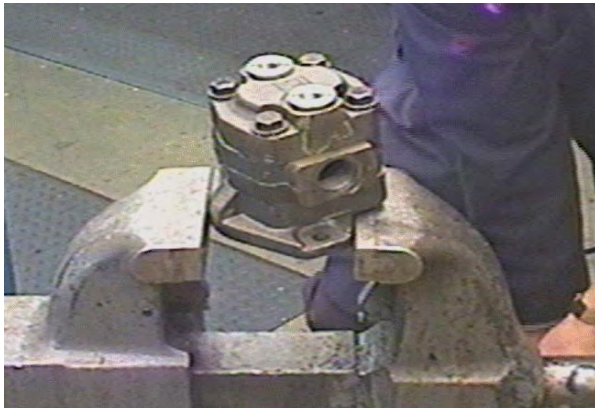

Place the pump in a vise with the drive shaft pointing down. Clamp unit on the sides of the mounting flange. Do not clamp on the pilot diameter as it may damage the seating surface.

## STEP 2



Mark each casting in the assembly with machinist's ink or a prick punch to orient the castings so unit can be reassembled later in the proper position.

## STEP 3



Loosen and remove the four cap screws and washers with a socket and wrench.

## STEP 4.1



Remove the port end cover subassembly using steps 4.1 through 4.3:

4.1 Place the point of a large screw driver or a chisel on the parting line between the port end cover casting and the gear housing casting. Gently tap to separate the casings and port end.

#### STEP 4.2



4.2 Place two large flat bladed screwdrivers into the separation notches and pry up the port end cover until loose.

#### STEP 4.3



4.3 Lift off the port end cover subassembly.

#### STEP 5.1



Remove the gear housing subassembly using steps 5.1 through 5.3:

5.1 Place the two large flat bladed screwdrivers into the separation notches and pry up the gear housing until loose.

#### STEP 5.2



5.2 Lift off the gear housing subassembly.



### STEP 5.3



5.3 Remove the thrust plate from the housing. It may be necessary to gently tap the thrust plate with the handle of a hammer or screw driver. Be careful not to bend or score the thrust plate. Remove and discard the small rubber pocket seals from the thrust plate.

### STEP 6

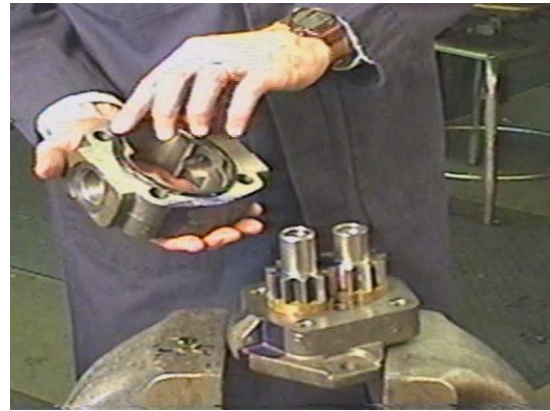

Remove and discard the rubber section seals from the top and the bottom gear housing faces.

### STEP 7



Wipe the gear face surface dry with a clean lint free cloth. Mark the teeth of the gear set at their mesh point with machinist's ink or quick dry marker. This is to index the gear set for proper orientation during reassembly.

### STEP 8



Remove the idler gear and the gear shaft. Keep them together as they are a matched set. Handle with care to avoid damage to the journals, faces, and teeth.

### STEP 9



Gently lift off the thrust plate. Be careful not to bend or score the plate and mating surface of the casting. Remove and discard the rubber pocket seals from the back of the thrust plate. NOTE: Pay attention to the orientation of the oil seal and channel on the bottom of the thrust plate.

### STEP 10



Inspect the bushings for wear. Replace following the next steps if required.

### STEP 11



Use a bearing puller to remove the bushings.

Note: This step is optional depending on the condition of the bushings.

### STEP 12



Use a large screw driver or a Check Tool to remove the check valves.

**STEP 9**



Inspect all the components for wear and replace as required.

**STEP 10**



Remove the channel seals and discard.

# Failure Analysis

## Large Particle Contamination

Particles too large to fit between the tight component tolerances of the gear pump or motor will cause surface to surface contact removing material from the softer thrust plate. Damage to the thrust plate surface, which provides a sealing surface between the high and low pressure oil, leads to leaks and a loss of performance. Additionally, continued wear due to the introduction of large contaminants results in additional contaminants, which perpetuates the overall problem.

The pump thrust plate is one of the best places to look for evidence contributing to the pump failure. Score marks on the plate in the photo indicate a “trail” of contaminants which were dragged across the surface of the plate.



New components provide a smooth, even surface allowing a continuous oil film to exist between the thrust plate and gear face. When these surfaces become scored the oil film dissipates into the grooves interrupting the film. Metal to metal contact occurs, resulting in an increase in friction and heat. The grooved plate surface can also provide an escape route for high pressure oil to go back to the low pressure inlet, resulting in a loss of pumping efficiency.

Large contaminants lodged in the spaces between the gear teeth will result in scoring of the pump housing.



Large particle contamination may also result in damage to the gear teeth.



## Small Particle Contamination

Microscopic particles the size of airborne dust can accumulate in the tiny tolerances of the hydraulic system. These particles can form a wedge between moving parts, increasing friction and accelerating wear. The velocity of the tiny particles striking the wear surfaces can erode material, weakening the wear surface and causing spalling. This erosion of metal leads to internal leaks in critical components and adds additional contamination to the hydraulic system. This wear reduces the system efficiency and affects pump or motor performance.

Smaller contamination particles will be evident on the thrust plate in the form of small score lines, and is most evident at the pressure point of the gear mesh.

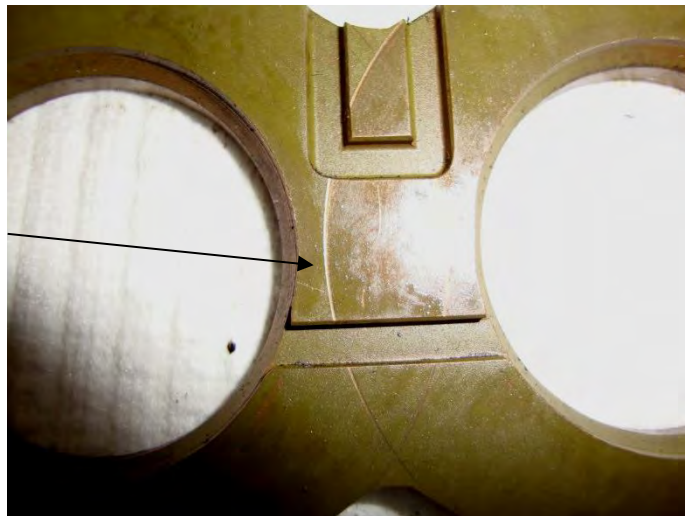

Contamination wear will also be present on the bushing surface of the pump drive shaft.

Small contaminants will produce minor scoring of the shaft. Large particles may produce severe wear and galling of the shaft surface



## Cavitation

Excessive noise in a hydraulic system can be caused by the presence of air in the hydraulic oil. Introduction of air into the system can be the result of a leak in the suction line, air bubbles entrained in the oil, or insufficient pump or motor inlet flow which results in a vacuum. The partial vacuum vaporizes some of the oil causing air and or water to come out of solution.

As the bubbles, created by cavitation and aeration, are carried around to the pump outlet, the increase in pressure squeezes the bubbles. Implosions occur when the pressure becomes too great and the bubbles collapse inward.

Air bubbles under pressure will implode and produce intense shock waves which bombard the surface of the thrust plates. This process erodes the plates' surfaces on the high pressure side. This erosion reduces pump efficiency and results in increased wear due to loss of the hydraulic film which normally protects from metal to metal contact.

Cavitation is shown on the thrust plate on the pressure outlet side of the pump in the form of pitting in the thrust plate surface.

Discoloration of this thrust plate may also indicate that excessive heat due to lack of oil supply was also present.

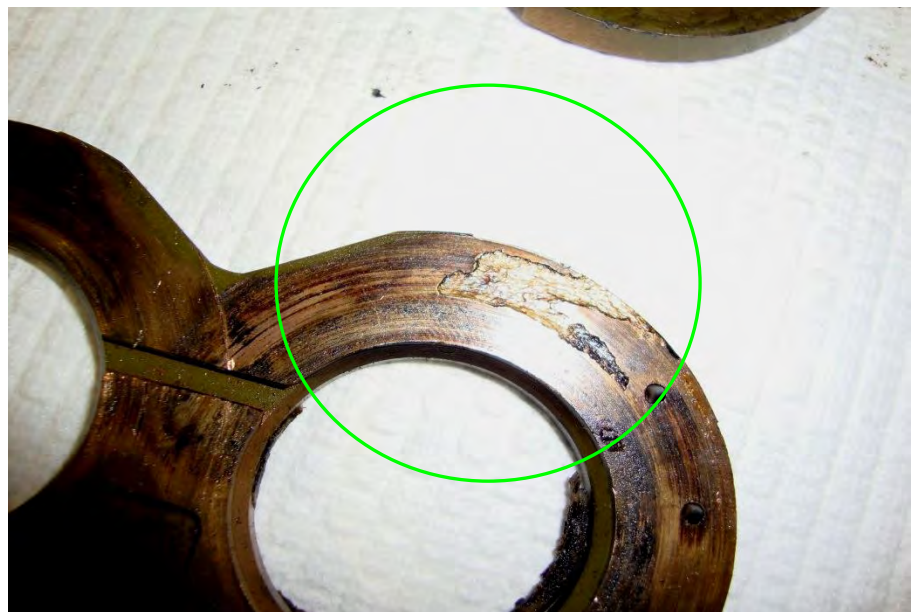

## Excessive System Pressure

Pressure and hydraulic shock are also causes of pump failure. Pumps operating under a continuous load at high pressure and for extended periods are susceptible to premature wear and failure. In addition normal operation of tree cutting or heavy brush cutting can cause sudden pressure spikes which may act on the system too fast for the pressure relief valves to respond and protect the system from damage.

Forces generated by the pump outlet pressure and gear area causes a deflection of the gears. This stresses the bushings that support the gear journals. The oil film needed to lubricate and cushion the pump elements becomes thinner with the increase in pressure until direct contact is made

System pressure in excess of the rated system pressure will affect the pump or motor either over time if the excessive pressure is static, or immediately if the excessive pressure is presented as a spike load.

Initially, damage resulting from excessive pressure will be displayed as cutouts exceeding 0.007" in depth inside the gear case housing. The system pressure deflects the gears into the low pressure inlet side of the pump. If the system pressure increases above the pressure rating of the pump, the gears deflect too far and the gear housing cut out becomes excessive. Internal slip increases and the pump will become less efficient. The contaminant created by the cut out can foul relief valves and other system components.

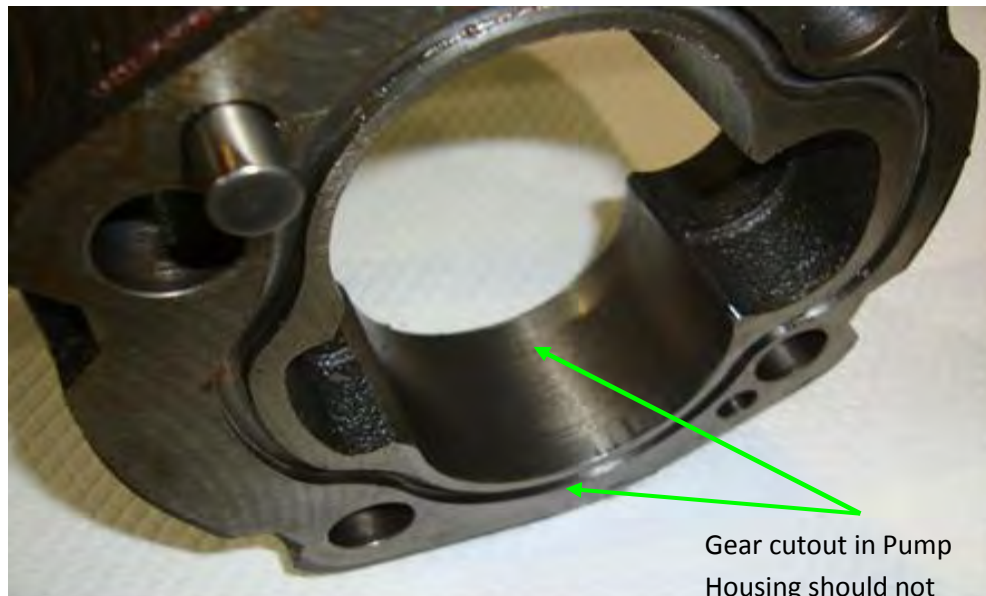

Gear cutout in Pump Housing should not exceed .007"



Excessive pressure and deflection of the gears in the pump housing will also result in the loss of the lubricating film between the pump shafts and the bushings. Continued high pressure will degrade the bushing and result in the bushing spinning in its housing.

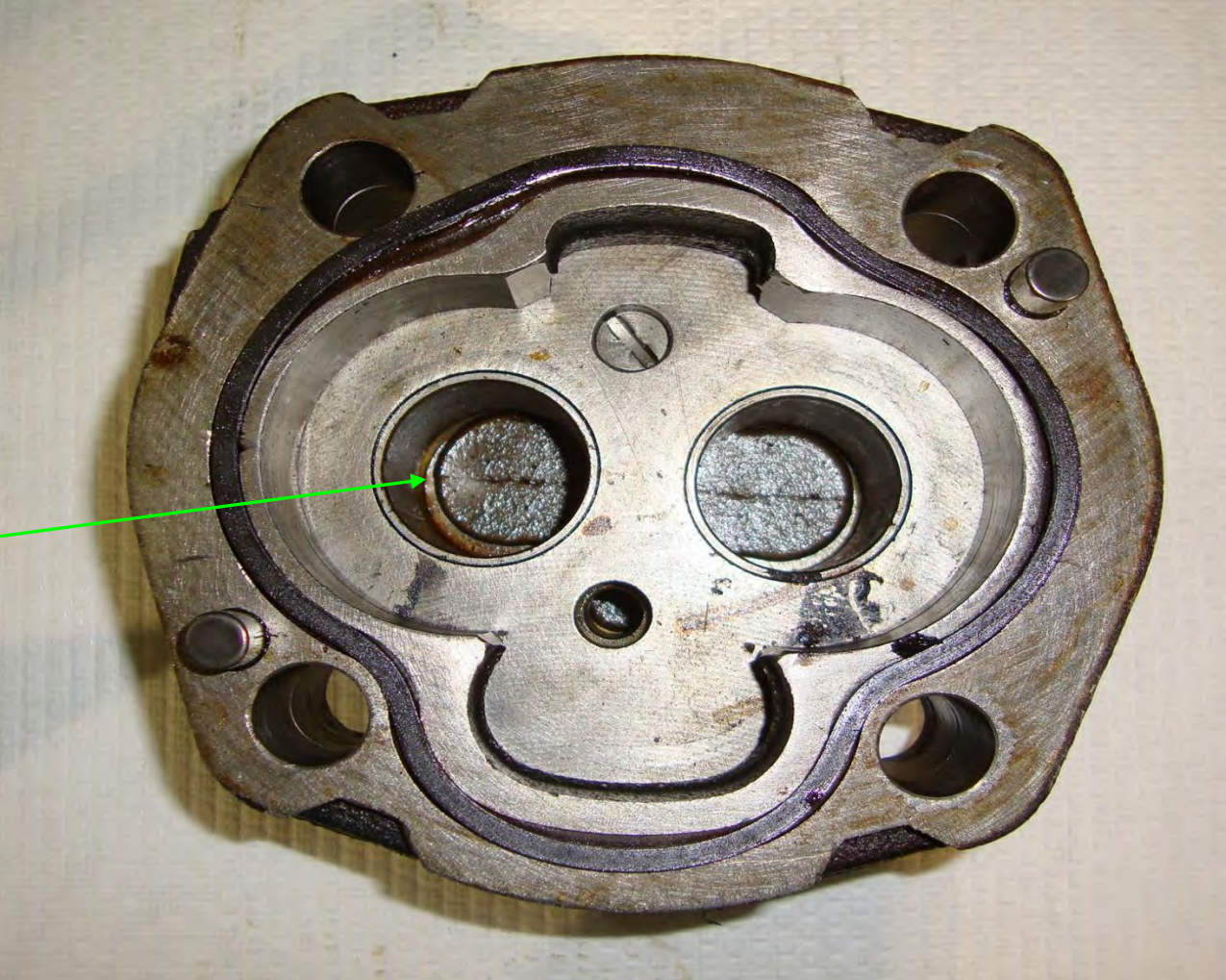

Hydraulic shock loads to the hydraulic system normally result from excessive ground speed while cutting heavy brush or trees and will be displayed as either cracks in the gear pump housing or a broken drive shaft. Shock loads can cause an immediate component failure. Sudden pressure spikes that exceed the pressure rating of the pump can crack the housing at the port location and bolt hole areas of the casting, severely scoring the thrust plate surface, and damage the drive shaft.

Sudden shock loads produced by sudden over-pressurization of the hydraulic system may cause sudden failure of the pump drive shaft.

Transverse torsional shear due to a high, single overload application.



Torsional overload resulting in transverse shear.

Smooth surface with swirl pattern and “barber poling” plastic deformation of the shaft.

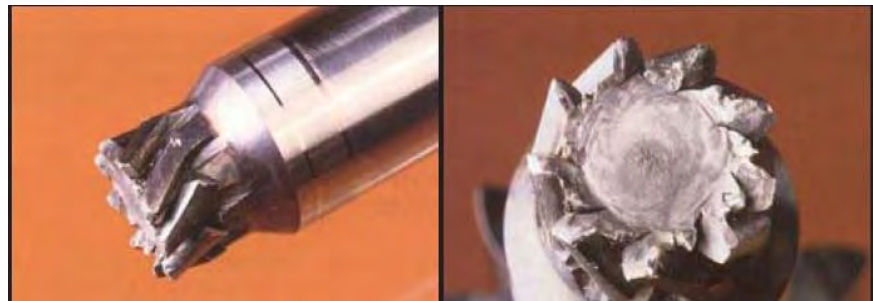

Over-pressurization of the hydraulic system could be the result of a slow acting or malfunctioning main pressure relief valve, restrictions in the return to tank connection from the motor, or malfunctioning motor and pump control components. Over-pressurization can also occur from a failed quick disconnect fitting or a kinked hose.

## Heat Damage

Heat is generated in a hydraulic system whenever oil dumps from an area of high pressure to low pressure without doing mechanical work. Oil blowing over a relief valve, or flowing through piping, bypassing a damaged o-ring, a valve, a clogged filter or strainer are all examples of sources of heat. Proper reservoir size can dissipate much of the heat generated in a system. On some applications an oil cooler must be added to sufficiently cool the oil. Other factors, such as contamination, cavitation / aeration, improper oil viscosity can add to the heating problems of a hydraulic system. In addition, excessive rotation speed of the pump due to high input speed of the engine or power source can also create excessive heat.

Heat buildup causes the hydraulic oil to lose its viscosity, resulting in oil that no longer meets specification. This greatly reduces the lubricating effects of the oil on the close tolerance parts. The heated oil oxidizes, encouraging corrosion, leakage, and the development of sludge which can clog filters and compound the heating problem.

Every 18°F rise in oil temperature doubles the rate of corrosion on exposed surfaces

### Excessive Heat:

- **Thins the system oil**
- **Accelerates the breakdown of the oil**
- **Promotes oxidation**
- **Can be caused by worn components or excessive engine speed**

With the loss of lubrication the thrust plate becomes heated rapidly. The plates become so hot that lead in the alloy will be drawn out of the plate and is smeared over the surface by the rotating gears. The result is that the entire plate will become blackened.



The excessive heat will also result in severe damage to the nylon channel seal and butyl rubber seal on the back of the thrust plate thus propagating further damage to the entire pump and hydraulic system.



Exposure to excessive heat will also discolor the ends of the gear teeth near the gear face. The high heat causes bluing of the teeth. With continued operation the gear face and thrust plate will start to weld together. Friction generated from continued operation could eventually result in a seized pump.



Hydraulic oil temperature should be monitored continuously during operation of the mower to prevent catastrophic failures due to high temperature operation.

Typical operating tolerances allow the system to operate at a temperature up to 100°F over the ambient temperature. On some applications an oil cooler must be added to sufficiently cool the oil. If the system is operating with excessive temperatures, the unit should be shut down to allow it to cool, and the source of overheating should be corrected prior to operating the unit.

## Part Replacement Guidelines

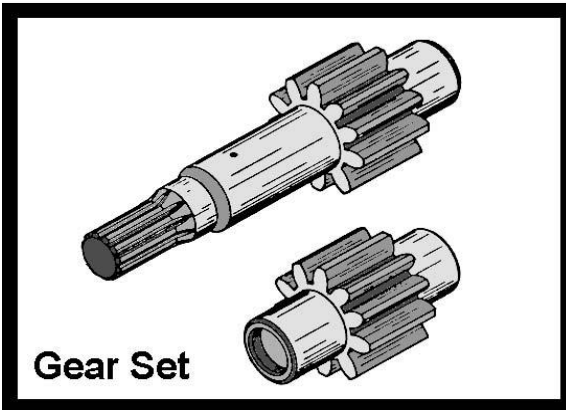

If the Gear Set contains any of the following defects, it should be replaced:

- Wear on the hubs or in the seal areas detectable by touch or in excess of .002”.
- Score marks, grooves, or burrs on the outside diameter of the teeth.
- Nicks, grooves, or fretting of the teeth surfaces.
- Wear or damage to the drive spline, key, or keyway.

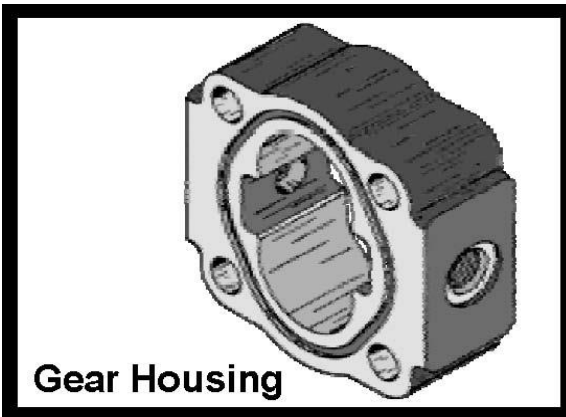

Wear in excess of .007” cut-out necessitates replacement of gear housing. Place a straight-edge across the bore. If you can slip a .007” feeler gage in the cut-out area, replace the gear housing.

Where the cut-out is moderate, .005” or less, the gear housing is still in good condition. If the housing has equal size ports or no ports, the housing may be flipped 180° (exchanging ports) and reused.

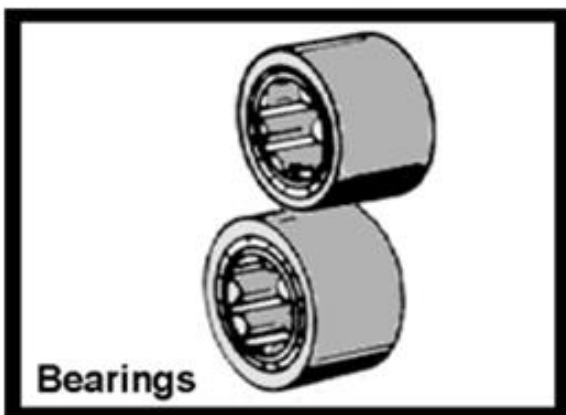

If the gears are replaced, then the bushings must be replaced also. Bushings should fit into the bores with a light press fit.

## Part Replacement Guidelines



Any scratches, grooves, erosions, or pitting on the thrust plate face, the area that comes in contact with the gear faces, necessitates the replacement of the thrust plates.



Replace all rubber and polymer seals whenever disassembling the pump. This includes the lip seal, pocket seal strips, and section seals.

**Always consult your factory Customer Support Representative before ordering replacement parts. Often the cost of rebuilding a pump or motor exceeds the replacement costs of an entire assembly. In this case the OEM supplier may not even offer a complete list of parts due to their high costs as repair parts.**

## Drive Shaft

Alamo can use 1 of 2 types of driveline system to couple the pump to the front of the tractor's motor.

1. The most common use is a straight driveline with splines on both ends. There will be a pulley adapter or hub with a splined coupler welded in place that is designed to fit the specific tractor application. This is bolted to the tractor's motor crankshaft pulley either directly or with the aid of a machined pulley adapter. The straight driveline is inserted into this adapter or hub and a free floating splined coupler connects opposite end of the shaft to the input shaft of the pump.

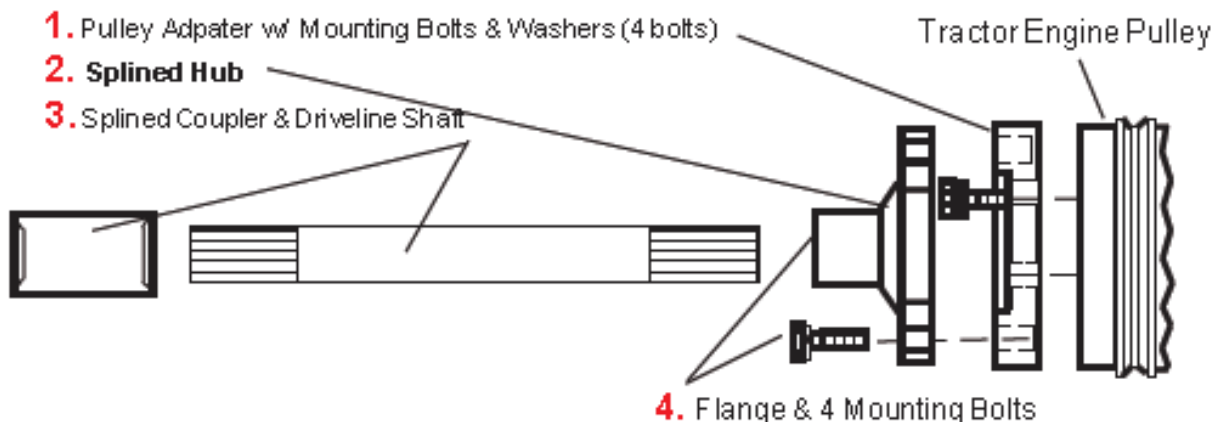

2. The second type is a U-Joint type of telescoping driveline. This will attach to the pulley face with a mounting flange and the pump end attaches to the pump by the means of a clamp yoke.

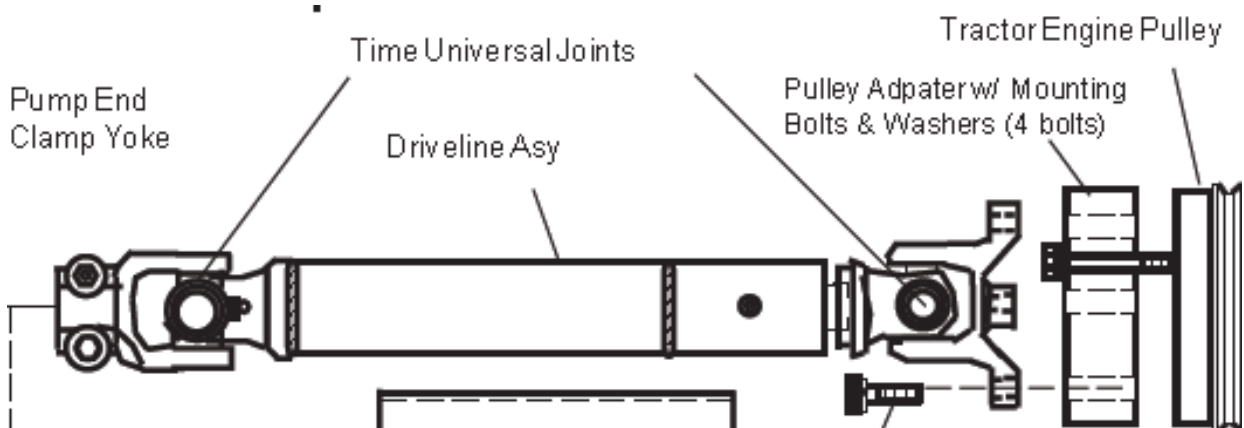

## Common Drive Shaft Issues

**Misalignment** - This is a mode of failure associated only with the straight shaft (no U-Joint) design. Typically this failure will result in excessive wear to all the splined areas of the shaft assembly including the pump shaft, coupler and both ends of the drive shaft. Typical wear results in a barrel shaped pump drive shaft such that the splines are worn down on each end. Likewise, the internal splines of the coupler may be worn in a concave shape around the inside diameter. Progression will result in the total loss of spline engagement and loss of power to the pump. Other symptoms include pump shaft fatigue failures, fretting and pump bearing failures. Alignment should be checked with a straight edge between the new pump shaft and the splines of the crank shaft adapter without the shaft in the system. Likewise, vibration can be observed by watching for high frequency movement of the shaft during operation.

**Rotating Bending Fatigue** as evidenced by beach marks around the circumference. Final fracture is brittle, with a rough center region. (Shown bottom left)

Final failure is caused by cyclical loads or from misalignment.

**Sporadic overpowering** of the drive system will result in wear of the pump and coupler splines in one direction as well as fretting corrosion on the pump shaft. This failure is attributable to powering the mower into heavy brush or limbs rather than a slow controlled cutting operation. (Shown bottom right)

Shaft failure comes from sporadic overload. This shaft also shows some rounding indicative of misalignment.

Overpowering will also be indicated by wear on bushings in the crankshaft adapter or related components.





**Lack of lubrication** of the drive shaft components will result in wear to the splines. High pressure grease or anti seize compound must be applied to all components during installation and replaced at regular intervals throughout the life of the machine.



The Drive shaft in the figure displays an example of **fretting corrosion**. Fretting is a condition that occurs between the drive shaft and the drive coupling. These parts are commonly lubricated with a heavy grease/ anti-seize agent. Fretting damage occurs when the grease picks up grit and the small amplitude vibration associated with the normal operation of the mower makes the contaminated grease act like sand paper and produces wear on the shaft.



As the wear progresses, the clearance between the parts becomes greater allowing more shaft coupling movement. The wear accelerates until there is not enough engagement to carry the torque load produced during mowing or tree trimming. As a result, the coupler will spin on the shaft and the pump will stop working. To repair, the pump gear set, coupler and shaft will need to be replaced.

# Pump and Motor Repair Procedures – Re-Assembly

## STEP 1



Stone all machined casting surfaces with a medium grit carborundum stone. If the bushings were removed, deburr the bushing bore using a deburring tool. Rinse all parts in a solvent fluid. Air blast all parts and wipe them clean with a clean lint free cloth before starting the assembly.

## STEP 3



Place the shaft end cover on an arbor press with the pilot facing up. Place the lip seal, with the shoulder of the seal up, at the top of the seal bore. Press the lip seal into the shaft end cover with a lip seal installation bar. The seal should be pressed in so it is flush with the recessed face in the shaft end cover casting.

## STEP 2



Coat the outside diameter of the lip seal with Permatex Aviation Form-A-Gasket No.3 Non-Hardening Sealant or equivalent.

Be careful not to get Permatex on the inner lip of the seal as it will cause a lip seal failure.

## STEP 4



Apply Loctite® No.262 to the threaded check holes in the shaft end casting. Install the checks in the shaft end cover using the check tool

**The checks must bottom out in the casting.**

#### STEP 5



Peen over the check holes in the shaft end cover with a 1½” steel ball and a hammer. This will insure that the checks do not back out of the check holes during operation.

#### STEP 6



If the shaft seal was removed from the shaft end cover, It should be replaced at this time.

#### STEP 7



Install the bushings in the shaft end cover and the port end cover. Use an arbor press to press the bushings into the bottom of the bearing bores.

#### STEP 8



Replace the channel seals in the groove provided on each thrust plate.

### STEP 9



Locate the orientation mark on the gear housing and line it up with the mark on the shaft end cover. Slide the gear housing over the gear set. Make sure that the gear housing rests tightly against the shaft end cover. Be careful not to pinch the section seal. Squirt clean hydraulic oil over the gear shaft and the idler gear to provide initial lubrication when the pump is started.

### STEP 10



Install the port end thrust plate onto the gear set. Make sure the channel seals are properly oriented.

### STEP 13



Place the port end cover over the gear journals. The orientation mark on the port end cover must line up with the mark on the gear housing. Apply pressure to the casting with your hand or tap lightly with a soft faced hammer until the port end cover rests tightly against the gear housing.

### STEP 14



Thread the four cap screws with the washers into the shaft end cover and tighten them in a cross corner pattern. Rotate the gear shaft of the pump with a 6" wrench to make certain there is no binding in the pump.

### STEP 15



Place the port end cover over the gear journals.

The orientation mark on the port end cover must line up with the mark on the gear housing. Apply pressure to the casting with your hand or tap lightly with a soft faced hammer until the port end cover rests tightly against the gear housing.

### STEP 16



Thread the four cap screws with the washers into the shaft end cover and tighten them in a cross corner pattern. Rotate the gear shaft of the pump with a 6" wrench to make certain there is no binding in the pump.

### STEP 17



After the cap screws are tightened and you are sure there is no internal binding, tighten the cap screws in a cross corner pattern to a final torque.

## Lubrication and Oil Recommendations

All parts are lubricated by the hydraulic oil in the circuit. Particular attention must be paid to keep the oil in the system clean. Whenever there is a pump or motor failure and there is reason to suspect that metal particles may be in the system, the oil must be drained, the entire system flushed clean, and any filter screens thoroughly cleaned or replaced. New oil should be supplied for the entire system. Only suitable and recommended oil for use in circuits involving Alamo supplied pumps and motors should be used.

Refer to the Recommended Lubricant Chart attached to the hydraulic tank or refer to the unit's Operator's Manual to determine the required hydraulic oil.

Using good quality hydraulic oil conforming to the specifications listed on the resources above is essential to satisfactory performance and long life of the hydraulic system.



Use only filtered oil to fill the hydraulic system to avoid contamination.

Oil used should conform to ISO 4406:99 standards for cleanliness and must meet a **minimum cleanliness of 18/16/14** before being installed in the mower



All operators should be properly trained to monitor the Return Filter Pressure Gauge during Operation. The gauge at start up, or when cold will indicate a reading in the "red" portion of the gauge. After warm up, the reading will fall to the green area if everything is normal. If pressures stay in the red zone after warm up, the filter should be replaced.

Oil should be changed on regular schedules in accordance with the manufacturer's recommendations and the system should be periodically flushed.



## Recommended Test Procedure

If one section of a tandem pump is being tested, make sure that all other sections not being tested are adequately supplied with oil. If any of the other sections run dry or if plugs are left in ports, serious and permanent damage will result.

Use a suitable Pressure/Flow meter which incorporates a Pressure Gauge (6000psi), a Temperature Gauge, Flow Meter and Flow Restriction Needle Valve.



Be sure there is an adequate supply of oil for the pump.

The oil should be good quality hydraulic oil rated at 150 SSU at 100° F with the oil temperature held at 120° F plus or minus 5° F (Test procedures are described in detail in SAE handbooks; see Hydraulic Power Pump Test Procedure SAE J745c.)

Install the Pressure/Flow Meter in place of the Motor in the hydraulic Circuit.

Note: DO NOT INSTALL the Pressure/Flow meter in the line directly from the pump to the Brake Valve. This line is NOT PROTECTED from over-pressurization by a Pressure Relief Valve. Hot oil must not be fed into a cold pump. The pump could seize.

## TESTING GEAR PUMP W/ FLOW METER

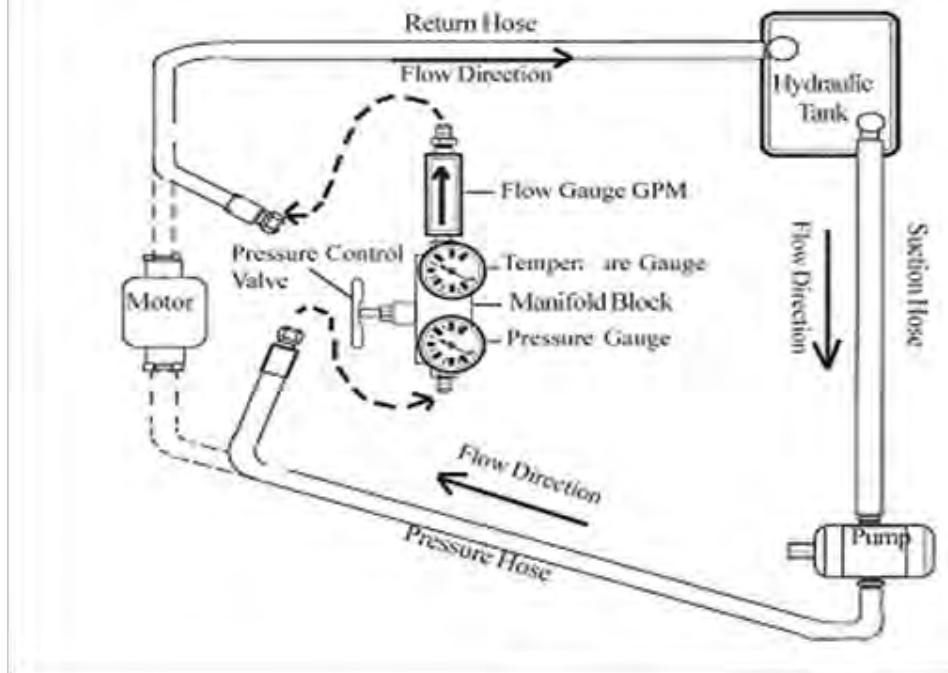

Operate the pump at least two minutes at zero pressure and at moderate speed (not over 1500 rpm). If pump becomes hot to touch, it is binding and could seize. This doesn't happen very often, but if it does, pump will have to be disassembled and be rebuilt. Extra care should be taken to remove burrs and to assure freedom from binding. Gradually increase the pressure on a pump intermittently until the desired test pressure has been reached. This should take about five minutes. Delivery should run close to the rated catalog performance figures which are averaged from testing of several pumps. A 5% lower reading may be used as a rated minimum if new or relatively new parts have been used. When rebuilding the pump with used parts from the original pump, that is only those parts which appear to be satisfactory for re-use, a 10% or 15% lower reading is permitted depending on the performance expected from the equipment. One's own experience will prove the best guide here.

Pumps and motors used on Alamo Mowers are designed to operate with the tractor's motor speed at 1800 to 2150 RPM. Never exceed 2400 RPM at any time.

Check the mower's Operator's Manual or Service Manual for specific specifications. In general, a good pump will maintain 75-80% of its rated flow up to relief pressure.

